

**OCEANO COMMUNITY SERVICES DISTRICT**  
**NORSWING/PERSHING WATERLINE REPLACEMENT PROJECT**

**OCEANO, CA**  
**CONTRACT NO. 2019-03**

---

- (i) Notice Inviting Bids**
- (ii) Instructions to Bidders**
- (iii) Blank Bid Forms**
- (iv) Construction Contract between District and Contractor**
- (v) General Conditions**
- (vi) Plans and Drawings**
- (vii) Special Provisions and/or Technical Specifications**
- (viii) Reports, Supplements, Attachments, Modifications, and Exhibits attached to the above items including the following:**
  - a. County of San Luis Obispo Encroachment Permit ENC 20190249**
- (ix) Insurance Requirements**
- (x) Blank Performance and Payment Bond Forms**
- (xi) Rules Governing Bid Protests**
- (xii) Bidding Addenda, if any**

**Deadline for submittal: December 6, 2019 at 3:00PM**

**OCEANO COMMUNITY SERVICES DISTRICT**

**NOTICE INVITING BIDS**

**FOR**

**Norswing/Pershing Waterline Replacement Project**

**OCEANO, CA  
CONTRACT NO. 2019-03**

**OCEANO COMMUNITY SERVICES DISTRICT  
NOTICE INVITING BIDS**

Notice is given that sealed bids will be received at the District office located at 1655 Front St.,  
before 3:00 p.m. on Friday, December 6, 2019 ("Bid Deadline"),  
for the following public works project:

**Norswing/Pershing Waterline Replacement Project  
OCEANO, CA  
CONTRACT NO. 2019-03**

Bids will be opened and declared by the District Business and Account Manager at 3:15 p.m. on December 6, 2019 at a public meeting at 1655 Front Street, Oceano, CA, 93445.

Any bid received at the District Office at or after 3:00 p.m. on the date specified above will not be accepted and will be returned to the bidder unopened.

Bids are required for the entire work described in the Contract Documents. The award of the contract, if it be awarded, will be to the responsible bidder with the lowest responsive bid price on the **GRAND TOTAL BASE BID EXCLUDING ADDITIVE BID ITEMS**. The District does not currently include any additive bid items on the bid sheet but reserves the right to include an additive bid item with an addendum if necessary. If additional additive bid items are included with an addendum, then the addendum will state how the lowest responsive bid price will be determined. The District reserves the right to the award of the contract after the lowest responsible bidder has been determined, and the bidder is bound by its bid amount including additive bid items, if any. Such award, if made, will be made within 90 calendar days after the opening of proposals, and bidder agrees to be bound by its bid, including all of its bid prices, for the entire 90-day period. The District reserves the right to reject all bids and the right to self-perform the work as provided by Public Contract Code Section 22038. The District's Contract No. 2019-03 is not federally funded.

**Description of Work**

The work is comprised of providing all necessary labor, materials, equipment, and supervision to install approximately 900 linear feet of new 8-inch water main, valves, fire hydrants and service laterals in Oceano, California as specified herein, as shown on the Contract Drawings and in accordance with standards established in Encroachment Permit No. ENC20190249 issued by the County of San Luis Obispo Department of Public Works. The work will include trenching and placement of structural backfill and new asphalt in accordance with County standards.

The work is located on Norswing and Pershing Drives, with connections on Pier Avenue and Truman Drive in Oceano, California. The contractor must comply with permit conditions established by the County of San Luis Obispo – Encroachment Permit # ENC20190249.

## Bid Documents

The following collection of documents are designated as the Bid Documents:

- (i) Notice Inviting Bids.
- (ii) Instructions to Bidders.
- (iii) Blank Bid Forms.
- (iv) Construction Contract between District and Contractor.
- (v) General Conditions.
- (vi) Plans and Drawings.
- (vii) Special Provisions and/or Technical Specifications.
- (viii) Reports, Supplements, Attachments, Modifications, and Exhibits attached to the above items including the following:
  - a. County of San Luis Obispo Encroachment Permit ENC 20190249.
- (ix) Insurance Requirements
- (x) Blank Performance and Payment Bond Forms
- (xi) Rules Governing Bid Protests
- (xii) Bidding Addenda, if any.

### NOTICE PURSUANT TO THE UNIFORM PUBLIC CONSTRUCTION COST ACCOUNTING ACT (Act)

The District's estimated project costs are \$178,265. Since project costs are estimated at less than \$200,000, noticing is being provided pursuant to the Act.

In accordance with Public Contract Code 22034(a)(2), a notice inviting informal bids including a description of the project in general terms and how to obtain more detailed information about the project, and the time and place for submission of bids, has been emailed to the following construction trade journals:

<b>Required Journals</b>	<b>San Luis Obispo County Journals</b>
Construction Bidboard (Ebidboard) 11622 El Camino Real, #100 San Diego, CA 92130 Phone: 800-479-5314 Email: support@ebidboard.com Website: www.ebidboard.com	Central Coast Builders Association 242 East Romie Lane Salinas, CA 93907 Phone: 831-758-1624 Email: staff@ccbabuild.com Website: www.ccbabuilds.com
Dodge Data & Analytics 830 Third Avenue, 6th Floor	San Luis Obispo County Builders Exchange 153 Cross Street, #130

New York, NY 10022 Phone: support@construction.com Email: support@construction.com Website: www.construction.com	San Luis Obispo, CA 93401 Phone: 805-543-7330 Email: info@slocbe.com Website: www.slocbe.com
---	---

Obtaining detailed information, which is the Bid package, (also referred to herein as the “Contract Documents”) are posted on the District’s website:

<http://www.oceanocsd.org>

If the website and/or links are not providing access to the bid package and related information, please contact the District's Business and Accounting Manager at 805-481-6730.

Any changes, additions, or deletions to these Contract Documents will be in the form of written addenda issued by the District. Any addenda will be posted on the website. Prospective bidders must check the website for addenda or other relevant new information at up to 5:00 p.m. the day before the prescribed date/time for submittal of bids. The District is not responsible for the failure of any prospective bidder to receive such addenda. All addenda so issued shall become a part of this Bid.

All bidders are required to acknowledge and confirm receipt of every addendum in their bid proposal.

All bidder Requests for Information must be submitted no later than 3:00 p.m., 5 business days prior to the bid opening date. Requests submitted after said date may not be considered. All questions pertaining to the content of this invitation to Bid must be made in writing through the District website. Questions and responses will be posted on the District website and can be viewed by accessing the Invitation to Bid located at the District website. The identity of the entity submitting the question will not be posted. The District reserves the right to determine the appropriateness of comments / questions that will be posted on the website.

The bidder must have either a Class A license or a combination of class C licenses that make up a majority of the work at the time the Contract is awarded (Public Contract Code § 3300). When the bidder holds a combination of Class C licenses, all work to be performed outside of the bidder’s license specialties, except work that is incidental or supplemental to the licenses of the bidder, shall be performed by licensed Subcontractors in compliance with the Subletting and Subcontracting Fair Practices Act (Chapter 4 (commencing with Section 4100) of Part 1 of Division 2 of the Public Contract Code)

Pursuant to section 1770 et seq. of the California Labor Code, the Contractor and all Subcontractors shall pay not less than the prevailing rate of per diem wages as determined by the Director of the California Department of Industrial Relations and comply with all applicable Labor Code provisions, which include, but are not limited to the employment of apprentices, the hours of labor, and the debarment of Contractors and Subcontractors. The Director of the California Department of Industrial Relations determines the general prevailing wage rates. Copies are available at the District Office or at the DIR website: [www.dir.ca.gov/DLSR/PWD](http://www.dir.ca.gov/DLSR/PWD) .

Pursuant to Public Contract Code section 1771.1:

- A Contractor or Subcontractor shall not be qualified to bid on, be listed in the Bid Proposal, subject to the requirements of Section 4104 of the Public Contract Code, or engage in the performance of this public works project, unless currently registered with the Department of Industrial Relations and qualified to perform work pursuant to Labor Code section 1725.5. It is not a violation of this section for an unregistered contractor to submit a bid that is authorized by Section 7029.1 of the Business and Professions Code or by Section 10164 or 20103.5 of the Public Contract Code, provided the contractor is registered to perform public work pursuant to Section 1725.5 at the time the contract is awarded.
- This Project is subject to compliance monitoring and enforcement by the Department of Industrial Relations.

Bids must be submitted under sealed cover plainly marked as a bid and identified with the project number, the date and time for receipt of sealed bids, and the name of the bidder.

Bids must be accompanied by cash, a certified or cashier's check, or a bidder's bond in favor of the District in an amount not less than ten percent (10%) of the submitted total Base Bid.

Pursuant to Public Contract Code section 22300, the successful bidder may substitute certain securities for funds withheld by District to ensure performance under the Contract or, in the alternative, request the District to make payment of retention to an escrow agent.

The successful bidder will be required to furnish the District with payment and performance bonds, with each issued by a California admitted surety insurer equal to 100% of the Contract Price.

By order of the General Manager of the Oceano Community Services District, made this \_\_\_\_\_ day of \_\_\_\_\_, 2019.

By \_\_\_\_\_  
Paavo Ogren, General Manager  
Oceano Community Services District

**OCEANO COMMUNITY SERVICES DISTRICT**  
**NORSWING/PERSHING WATERLINE REPLACEMENT PROJECT**  
**INSTRUCTIONS TO BIDDERS**  
**FOR**  
**OCEANO, CA**  
**CONTRACT NO. 2019-03**

## **INSTRUCTIONS TO BIDDERS**

### **1. CONTRACT DOCUMENTS**

The Contract Documents may be obtained from the District at the location specified in the Notice to Bidders.

The Contract Documents include the Notice to Bidders, Instructions to Bidders, Bid Forms, Construction Contract, General Conditions, Special Provisions and/or Technical Specifications,, Project Plans and Drawings other Contract Documents and insurance and bond requirements. Some contract documents may be incorporated by reference.

Contract Documents can be obtained from the District website at:

<http://www.oceanocsd.org>

If the website and/or links are not providing access to the bid package and related information, please contact the District's Business and Accounting Manager at 805-481-6730.

The District does not assume any liability or responsibility based on any defective or incomplete copying, excerpting, scanning, faxing, downloading, or printing of the Contract Documents.

### **2. JOB SITE AND CONTRACT DOCUMENT EXAMINATION**

Bidders are responsible for examining the job site and the Contract Documents, including any Addenda issued prior to the Bid Deadline, and for informing themselves with respect to local labor availability, means of transportation, necessity for security, laws and codes, local permit requirements, wage scales, local tax structure, contractors licensing requirements, availability of required insurance, and other factors that could affect the work. Bidders are responsible for consulting the standards referenced in the Contract Documents.

Submission of a Bid is a bidder's acknowledgment that the bidder has examined the job site and bid documents and is satisfied with:

1. General and local conditions to be encountered
2. Character, quality, and scope of work to be performed
3. Quantities of materials to be furnished
4. Character, quality, and quantity of surface and subsurface materials or obstacles
5. Requirements of the Contract Documents

### **3. PRE-BID CONFERENCE**

A pre-bid conference will not be held for this Contract.

### **4. ADDENDA**

The District reserves the right to revise the Contract Documents prior to the Bid opening date. Revisions, if any, will be made by written Addenda. All Addenda issued by the District shall be included in the Bid and made part of the Contract Documents. Pursuant to Public Contract Code section 4104.5, if the District issues an Addendum that includes material changes to the work less than 72 hours prior to the Bid Deadline, the District will extend the Bid Deadline. The District may determine, in its sole discretion, whether an Addendum warrants postponement of the Bid Deadline.

All Addenda issued will be posted on the following website: <http://www.oceanocsd.org>

Interested persons should be aware that if the website and/or links are not providing access to the bid package and related information, they should contact the District's Business and Accounting Manager at 805-481-6730.

Prospective bidders must check the website for addenda or other relevant new information during the response period. The District is not responsible for the failure of any prospective bidder to receive such addenda. All addenda so issued shall become a part of this Bid.

All bidders are required to acknowledge and confirm receipt of each and every addendum in their Bid. Failure to acknowledge all Addenda may result in a Bid being deemed nonresponsive and not eligible for award of the Contract.



## **5. ENGINEER'S ESTIMATE**

Any engineers estimate provided by the District relating to this work has been provided strictly for informational purposes and cannot be relied upon by any bidder as representing an accurate estimate of the value of the work. The purpose of providing any such engineer's estimate is simply to provide each potential bidder with some preliminary information relating to whether the work may be within its bonding capacity and available resources. Under no circumstance may a bidder rely upon the engineer's estimate as representing a reasonable value of the work.

## **6. COMPLETION OF BID FORMS**

Prepare bids using only copies of the Bid Forms, which are included in the Contract Documents issued by the District. The use of Bid Forms other than clear and correct photocopies of those provided by the District will not be permitted. Bids must be executed by an authorized signatory as described in these Instructions to Bidders. Bidders must fill in all blank spaces (including inserting "N/A" where applicable) and initial all interlineations, alterations, or erasures to the Bid Forms. Bidders must not delete, modify, or supplement the printed matter on the Bid Forms or make substitutions thereon. Use of black or blue ink, indelible pencil, or a typewriter is required. Deviations in the Bid Forms may result in a Bid being deemed nonresponsive and not eligible for award of the Contract.

## **7. LICENSING REQUIREMENTS**

Pursuant to section 7028.15 of the Business and Professions Code, bidders must possess licenses issued by the California Contractors State License Board for performance of this Contract. Subcontractors must possess the appropriate licenses for each specialty subcontracted.

The District has determined that bidders must have the class of license designated in the Notice to Bidders to be eligible for award of this Contract. The Contractor shall be properly licensed by the time the Contract is awarded, pursuant to the provisions of Public Contract Code section 20103.5. Failure of the bidder to obtain proper and adequate licensing for award of the Contract constitutes a failure to execute the Contract and shall result in the forfeiture of the security of the bidder.

## **8. REGISTRATION REQUIREMENTS**

A Contractor or Subcontractor shall not be qualified to bid on, be listed in a bid proposal subject to the requirements of Public Contract Code section 4104, or engage in the performance of this Contract unless currently registered with the California Department of Industrial Relations and qualified to perform public work pursuant to Labor Code section 1725.5. It is not a violation of Labor Code section 1725.5 for an unregistered Contractor to submit a Bid on this Contract provided the Contractor is registered to perform public work pursuant to Section 1725.5 at the time this Contract is awarded.

## **9. BID SECURITY**

Each Bid shall be accompanied by Bid Security consisting of: (a) cash; (b) a certified check made payable to the Oceano Community Services District; (c) a cashier's check made payable to the Oceano Community Services District; or (d) a bidder's bond in favor of the Oceano Community Services District executed by the bidder as principal and surety as obligor, in an amount not less than 10% of the total base Bid.

The surety insurer shall be admitted to transact surety business in the State of California, as defined in Code of Civil Procedure section 995.120. Personal sureties and unregistered surety companies are unacceptable. The cash, check, or bidder's bond shall be given as a guarantee that the bidder: (1) will execute the Contract if it is awarded to the bidder, and (2) shall provide the required payment and performance bonds and insurance certificates and endorsements as required by the Contract Documents. Failure to provide the required documents may result in forfeiture of the Bid Security and the District may award the Contract to another bidder or may call for new Bids.

## **10. BID ITEM LIST**

Bidder shall submit a Bid based on the bid item quantities the District shows on the Bid Item List. The Bid Item List is included in the Bid Forms.

In case of discrepancy between the unit price and the total set forth for a unit basis item, the unit price shall prevail, except as provided:

- A. If the amount set forth as a unit price is ambiguous, unintelligible, or uncertain for any reason, or is omitted, or is the same amount as the entry in the "Total" column, then the amount set forth in the "Total" column for the item shall prevail and shall be divided by the estimated quantity for the item and the price thus obtained shall be the unit price.
- B. (Decimal Errors) If the product of the entered unit price and the estimated quantity is exactly off by a factor of ten, one hundred, etc., or one-tenth, or one-hundredth, etc. from the entered total, the discrepancy will be resolved by using the entered unit price or item total, whichever most closely approximates percentage-wise the unit price or item total in the District's final estimate of cost.

#### **11. DESIGNATION OF SUBCONTRACTORS (Public Contract Code 4100-4114)**

On the *Designation of Subcontractors - Base Bid and the Designation of Subcontractors – Base Plus Additive Bid forms*, Bidders shall list each Subcontractor to whom the bidder proposes to directly subcontract portions of the work in an amount in excess of 1/2 of one percent of the total Bid. The *Designation of Subcontractors* forms for listing Subcontractors are included in the Bid Forms.

For each Subcontractor listed, the *Designation of Subcontractors* forms must show:

1. Business name and the location of its place of business.
2. California contractor license number.
3. Public works contractor registration number
4. Portion of work it will perform. Show the portion of the work by:
  - 4.1. Description of portion of subcontracted work
  - 4.2. Bid item numbers for the work involved in the portion of work listed
  - 4.3. Percentage of the total Bid for each bid item listed

#### **12. DEBARMENT OF CONTRACTORS AND SUBCONTRACTORS**

In accordance with the provisions of the Labor Code, Contractors or Subcontractors may not perform work on a public works project with a Subcontractor who is ineligible to perform work on a public project pursuant to section 1777.1 or section 1777.7 of the Labor Code. Any contract on a public works project entered into between a Contractor and a debarred Subcontractor is void as a matter of law. A debarred Subcontractor may not receive any public money for performing work as a Subcontractor on a public works contract. Any public money that is paid to a debarred Subcontractor by the Contractor shall be returned to the District. The Contractor shall be responsible for the payment of wages to workers of a debarred Subcontractor used on the work

A list of Contractors barred by the Division of Labor Standards Enforcements is available on the following Department of Industrial Relations website:

<http://www.dir.ca.gov/dlse/debar.html>

#### **13. DECLARATION OF NONCOLLUSION**

The *Declaration of Noncollusion* form shall be signed, under penalty of perjury, certifying that the Bid is not the result of and has not been influenced by collusion. Any Bid made without such declaration, or believed to be made in violation thereof, may be rejected.

#### **14. IRAN CONTRACTING ACT CERTIFICATION**

Each bidder shall submit the certification required by the Iran Contracting Act of 2010, Public Contract Code section 2200 et seq. with its Bid. The certification is included in the Bid Forms section of the Contract Documents.

#### **15. SIGNING OF BIDS**

All Bids submitted shall be executed by the bidder or its authorized representative. Bidders may be asked to provide evidence in the form of an authenticated resolution of its Board of Directors or a Power of Attorney evidencing the capacity of the person signing the Bid to bind the bidder to each Bid and to any Contract.

If the bidder is a corporation, the legal name of the corporation shall be set forth on the Bid Proposal Form with the signature of the officer or officers authorized to sign contracts on behalf of the corporation. If the bidder is a partnership, the true name of the firm shall be set forth on the Bid Proposal Form with the signature of the partner or partners authorized to sign contracts on behalf of the partnership. If the bidder is an individual, his or her signature shall be placed on the Bid Proposal. If signature is by an agent, other than an officer of a corporation or a member of a partnership, a Power of Attorney must be submitted with the Bid; otherwise, the Bid will be disregarded as irregular and unauthorized.

#### **16. SUBMISSION OF SEALED BIDS**

Once the Bid Forms have been completed and signed as set forth herein, place them, along with the Bid Security and other required materials, in an envelope, sealed, addressed, and delivered or mailed, postage prepaid, to the District as indicated in the Notice to Bidders. No oral or telephonic bids will be considered. No forms transmitted via the internet, e-mail, facsimile, or any other electronic means will be considered. Bids must be plainly marked as a Bid and identified with the Project number, the date and time of receipt of sealed Bids, and the name of the bidder.

#### **17. DELIVERY AND OPENING OF BIDS**

Bids will be received by the District at the address shown in the Notice to Bidders prior to the date and time shown therein. The District will leave unopened any Bid received after the specified date and time, and any such unopened Bid will be returned to the bidder. It is the bidder's sole responsibility to ensure that its Bid is received as specified. Bids may be submitted earlier than the date and time indicated.

Bids will be opened as stated in the Notice to Bidders, and the amount of each Bid will be read aloud and recorded. All bidders may, if they desire, attend the opening of Bids. The District may in its sole discretion, elect to postpone the opening of the submitted Bids. District reserves the right to reject any or all Bids and to waive any informality or irregularity in any Bid.

#### **18. WITHDRAWAL OF BID**

Any bidder may withdraw its Bid by written request any time prior to the time set forth in the Notice to Bidders for the opening of Bids by notice to the District's Business and Accounting Manager at 1655 Front Street, Oceano, CA 93445. Such notice shall be in writing signed by the bidder and shall be received, and date-stamped and time-stamped by the District. Withdrawn Bids may be resubmitted on or before the time set forth in the Notice to Bidders for receipt of Bids provided that they are in full conformance with the Contract Documents. Once submitted, all Bids are irrevocable, except as otherwise provided by law. Each bidder agrees by submitting a Bid that its Bid shall remain open, is irrevocable, and may not be modified, withdrawn, or cancelled for a period of at least 90 days after Bid opening. Any request for District's consent to permit a bidder to withdraw a Bid after the Bid Deadline must be made in accordance with Public Contract Code section 5100 et seq., including, but not limited to, submission of written notice to the District within 5 business days after Bid opening specifying in detail how the mistake occurred.

#### **19. RESERVATION OF RIGHTS**

The District reserves the right to reject any or all bids, and to waive discrepancies, irregularities, informalities, or any other error in the bid or bidding, if to do so seems to best serve the public interest. The right of the District to waive errors applies even if the Contract Documents state that a discrepancy, irregularity, informality, or other error make a bid nonresponsive, so long as the error does not constitute a material error.

The District reserves the right, in its sole discretion, to: judge the bidder's representations as stated in the Bid forms and any post-Bid information to determine whether or not bidder is qualified to perform the work; be the sole judge regarding the suitability of the products, services, or supplies offered; to not purchase all items or the full quantity of each item listed in the Bid Item List; reject any or all Bids; waive any deficiencies, irregularities, or informalities in any Bids or in the bidding process; modify, cancel, or withdraw the Notice to Bidders; issue a new Notice to Bidders; suspend or abandon the Project; seek the assistance of outside technical experts in Bid evaluation; require a bidder to provide a guarantee (or guarantees) of the Contract by a third party; and not issue a Notice to Proceed after execution of the Contract. In submitting a Bid in response to the Notice to Bidders, the bidder is specifically acknowledging the District holds these rights. The Notice to Bidders does not commit the District to enter into a Contract, to reject, in its sole discretion, all Bids, nor does it obligate the District pay for any costs incurred in preparation and submission of a Bid or in anticipation of a Contract. By submitting a Bid, the bidder disclaims any right to be paid for such costs.

**20. BASIS OF AWARD; BALANCED BIDS**

The District will award the Contract to the responsible bidder that submits the lowest responsive Bid, which shall be determined as set forth in the Notice to Bidders and as provided in these Instructions to Bidders and subject to the rights reserved by the District.

**21. DISQUALIFICATION OF BIDDERS; INTEREST IN MORE THAN ONE BID**

No bidder shall be allowed to make, submit, or be interested in more than one Bid. However, a person, firm, corporation or other entity that has submitted a proposal to a bidder, or that has quoted prices of materials to a bidder, is not thereby disqualified from submitting a proposal or quoting prices to other bidders submitting a Bid to the District, or submitting a Bid to the District as a prime bidder.

A firm that the District has hired to provide architectural or engineering services to the District for this Contract before Bid submittal for this Contract is prohibited from all of the following:

1. Submitting a Bid;
2. Subcontracting for a part of the work; and
3. Supplying materials.

**22. INSURANCE REQUIREMENTS**

The successful bidder shall procure and maintain insurance in the forms, in the amounts and for the durations specified in the General Conditions.

**23. RESPONSIVE BID**

A responsive Bid is a Bid that conforms, in all material respects, to these Instructions to Bidders. Non-responsive Bids will be rejected.

**24. RESPONSIBLE BIDDER**

A responsible bidder means a bidder who has demonstrated the attributes of trustworthiness, quality, fitness, capacity, and experience to satisfactorily perform fully the requirements of the Contract Documents and the moral and business integrity and reliability that will assure good faith performance in the sole discretion of the District. Any determination of a bidder's non-responsibility by the District shall be based on the fitness and capacity of the bidder to satisfactorily perform the obligations of the Contract, whether or not the bidder is qualified to perform those obligations, whether or not the bidder is trustworthy, and such other bases as may be relevant.

**25. EVIDENCE OF RESPONSIBILITY AND ADDITIONAL INFORMATION**

In addition to other provisions of the Bidding Requirements, upon the request of the District, a bidder whose Bid is under consideration for the award of the Contract shall promptly submit satisfactory evidence to District showing the bidder's financial resources, experience in the field, and organization and other factors evidencing bidder's ability to successfully execute and complete the Contract.

**26. AWARD PROCESS**

Once all Bids are opened and reviewed to determine the lowest responsive and responsible bidder, the District may award the Contract or reject all Bids. Once the District notifies the selected bidder of the award, the bidder will have 10 business days from the date of the award and tender of Contract to deliver to the District the executed Contract, all of the required bonds, evidence of insurance, and other materials set forth in the Contract Documents. Once the District receives all of the properly executed documents and certifications, the District will deliver the fully executed Contract to the Contractor and issue a Notice to Proceed. If the District's issuance of a Notice to Proceed is delayed due to Contractor's failure to return fully-executed Contract, insurance, bond, and other required documents within 10 working days after the award and tender of the Contract, then Contractor agrees to the deduction of 1 working day from the number of days in the Contract Time for every day of delay in District's receipt of said documents. This right is in addition to and does not affect the District's right to demand forfeiture of the Bid Security if Contractor persistently delays in providing the required documentation. The Contractor's failure to return all of the required documents within 10 working days may result in the award of the contract to the next lowest bidder or rejection of all bids if, in the General

Manager's sole discretion, it is determined that uncertainty in awarding and contract execution for the work impairs the District's ability to have the work completed in a timely manner.

**27. RETENTION AND SUBSTITUTION OF SECURITY**

The District will make monthly progress payments based upon work performed in accordance with the Contract Documents. Unless otherwise specified in the Notice to Bidders, the District will retain five percent (5%) of each progress payment as provided by the Contract Documents. At the request and expense of the Contractor, the Contractor may substitute securities for the amount so retained, or in the alternative, request the District make payment to an escrow agent in accordance with Public Contract Code section 22300. Contractor shall have 30 days following award of the Contract to submit a written request to the District to permit substitution of securities or payment of retention to an escrow agent; failure to do so shall be deemed a waiver of the right.

**28. PERFORMANCE BOND AND PAYMENT (LABOR AND MATERIALS) BOND REQUIREMENTS**

The successful bidder shall deliver to the District two (2) fully executed, identical counterparts of the performance bond and payment (labor and materials) bond in the form supplied by the District and included in the Contract Documents. The penal amount of each bond shall be for one hundred percent (100%) of the total base Bid plus the additive bid items, if added by District. The surety insurer shall be admitted to transact surety business in the State of California, in accordance with Code of Civil Procedure section 995.120. Personal sureties and unregistered surety companies are unacceptable. Failure to furnish a bond within this time may, in the sole discretion of District, result in the forfeiture of the Bid Security.

**29. SALES AND OTHER APPLICABLE TAXES, PERMITS, LICENSES AND FEES**

Contractor and its Subcontractors performing work under this Contract will be required to pay California sales tax and other applicable taxes, and to pay for permits, licenses, and fees required by the agencies with authority in the jurisdiction in which the work will be located, unless otherwise expressly provided by the Contract Documents. Bidders shall include all applicable taxes and fees that are in effect or reasonably anticipated at the Bid Deadline in all Bid prices.

**30. BID PROTEST PROCEDURE**

Bid protests and other challenges to the award of this Contract must comply with Rules Governing Bid Protests and Other Challenges to Awards of Construction Contracts ("Rules"). A copy of the Rules is attached to this Contract as an appendix. In addition, any Bid protest must be submitted in writing to the Oceano Community Services District, 1655 Front Street, Oceano CA 93445; Attention: General Manager.

**END OF INSTRUCTIONS TO BIDDERS**

**OCEANO COMMUNITY SERVICES DISTRICT**  
**NORSWING/PERSHING WATERLINE REPLACEMENT PROJECT**  
**BID FORMS**  
**FOR**  
**OCEANO, CA**  
**CONTRACT NO. 2019-03**

**OCEANO COMMUNITY SERVICES DISTRICT**

**BID FORMS**

**FOR**

**Norswing / Pershing Waterline Replacement Project**

**OCEANO, CA**

**CONTRACT NO. 2019-03**

**BID PROPOSAL FORM**  
**TO THE BOARD OF DIRECTORS**  
**OF THE OCEANO COMMUNITY SERVICES DISTRICT**

**Norswing / Pershing Waterline Replacement Project**  
**OCEANO, CA**  
**CONTRACT NO. 2019-03**

**NAME OF BIDDER** \_\_\_\_\_

**BUSINESS P.O. BOX** \_\_\_\_\_

**CITY, STATE, ZIP** \_\_\_\_\_

**BUSINESS STREET ADDRESS** \_\_\_\_\_  
(include even if P.O. Box used)

**CITY, STATE, ZIP** \_\_\_\_\_

**PHONE NO: AREA CODE (\_\_\_\_) \_\_\_\_\_**

**FAX NO: AREA CODE (\_\_\_\_) \_\_\_\_\_**

**CONTRACTOR LICENSE NO. \_\_\_\_\_ CLASSIFICATION \_\_\_\_\_**

**PUBLIC WORKS CONTRACTOR REGISTRATION NO: \_\_\_\_\_**

**TAX I.D. NUMBER: \_\_\_\_\_**

**BUSINESS TYPE (Check one): Corporation \_\_\_ Partnership \_\_\_ Sole Proprietorship \_\_\_\_\_**  
**Limited Liability Company \_\_\_**

**CONTACT PERSON NAME** \_\_\_\_\_

**CONTACT PERSON PHONE No.** \_\_\_\_\_

**CONTACT PERSON E-MAIL** \_\_\_\_\_

**EMPLOYER'S TAX IDENTIFICATION NUMBER** \_\_\_\_\_

Bidder agrees that the Bid and all prices shall remain open and shall not be withdrawn for a period of not less than **90 days** from the Bid Deadline, or until rejected by the District, whichever period is shorter.



**1. ADDENDA**

The undersigned acknowledges and confirms the receipt of the following Addenda:

<u>Addenda Number</u>	<u>Date</u>
_____	_____
_____	_____
_____	_____

and agrees that said addenda are covered in the bid proposal and shall form a part of the Contract Documents.

**2. CERTIFICATION OF INSPECTION OF THE SITE AND CONTRACT DOCUMENTS**

By signing below, bidder certifies that it: has received, carefully examined, and is fully familiar with all of the provisions of the Contract Documents, including all Addenda and attachments, and that said Contract Documents contain sufficient detail regarding the work to be performed; has notified the District of any errors or omissions in the Contract Documents and unusual site conditions; has carefully checked all words, prices, and statements in this Bid Proposal Form; and has visited the job site and conducted such other field investigations which are prudent and reasonable in preparing the Bid. Bidder agrees that the District will not be responsible for any errors or omissions on the part of the undersigned in making the Bid.

**3. BIDDER’S REPRESENTATIONS REGARDING INSURANCE AND BONDS**

This Bid is made with the full knowledge of the kind, quantity, and quality of the materials and work required and, if it is accepted by the District, the bidder will enter into a Contract and furnish the bonds, insurance and other documents including project schedule as required by the Contract Documents within 10 business days after award and tender of the Contract. **By its signature below, the bidder agrees to provide the proper evidence of insurance and bonds within 10 business days after District’s tender of the Contract. Failure to do so may result in forfeiture of Bid Security and rescission of the award by the District.**

**4. CONTRACTORS LICENSE CERTIFICATION.**

The undersigned certifies that:

Contractors License No. \_\_\_\_\_ issued by the California Contractors State License Board (“CSLB”) to the undersigned on, , is current, valid, has not been revoked, suspended or cancelled, and is appropriate to the work to be undertaken.

Contractors License Classification(s): \_\_\_\_\_

Expiration Date: \_\_\_\_\_

Name of Qualifying Individual: \_\_\_\_\_

**5. TIME FOR COMPLETION**

The bidder agrees that if awarded the Contract, it shall complete the work within 60 calendar days after the date specific in the District’s Notice to Proceed.

## 6. ATTACHMENTS TO THIS BID PROPOSAL FORM

Enclosed herewith (except as otherwise provided for optional forms) and by this reference incorporated herein and made a part of this Bid Proposal Form are the following items:

1. Bid Item List
2. Designation of Subcontractors Base Bid Form
3. Declaration of Noncollusion
4. California Public Contract Code 10162 Questionnaire
5. California Public Contract Code 10232 Statement
6. California Public Contract Code 10285.1 Statement
7. Iran Contracting Act Certification
8. Non-Lobbying Certification for Federal-Aid Contracts
9. Disclosure of Lobbying Activities
10. Bidder's Bond or other Bid Security

Bids are to be submitted for the entire work. The amount for Bid comparison purposes will be the total of all items.

The bidder shall set forth for each unit basis item of work a unit price and a total for the item, and for each lump sum item a total for the item, all in clearly legible figures in the respective spaces provided for that purpose. In the case of unit basis items, the amount set forth under the "Total" column is the extension of the unit price bid on the basis of the approximate quantity for the item.

Accompanying this Bid Proposal is a bidder's bond, cash, cashier's check, or a certified check, payable to the Oceano Community Services District, for the sum of at least ten percent (10%) of the total of the base bid. The proceeds thereof shall become the property of the District if the Bid is withdrawn after the time fixed in the Notice to Bidders for the opening of Bids, or if, in case this Bid is accepted by the District and such bidder has received written notice that the Contract has been awarded to him/her, the undersigned shall fail within 10 business days to execute the Contract with the District and furnish all documents required in the Bid Documents. Otherwise, said Bid Security, except a bidder's bond, will be returned to the undersigned.

**7. BIDDER'S ORGANIZATION AND SIGNATURE AUTHORIZATION**

The undersigned certifies that he/she/they is/are authorized to sign this Bid and any subsequent Contract on behalf of the bidding firm or company and that the nature of this bidding firm is an individual, partnership, corporation, or limited liability company with the principals or authorized officers of the firm listed as follows:

Nature of Firm:

(Corporation, Partnership, Individual, etc.) \_\_\_\_\_

Principal Officers/Partners/Members: \_\_\_\_\_

\_\_\_\_\_

Name of President of Corporation: \_\_\_\_\_

Name of Secretary of Corporation: \_\_\_\_\_

Corporation is organized under laws of State of \_\_\_\_\_, and is authorized to transact business in the State of California.

\_\_\_\_\_  
Company/Contractor Legal Name

\_\_\_\_\_  
Signature

\_\_\_\_\_  
Name (print/type)

\_\_\_\_\_  
Title (print/type)

\_\_\_\_\_  
Date

### BID FORM - BID ITEM LIST

#### BASE BID

ITEM NO.	DESCRIPTION OF ITEM	APPROX. QUANTITY	UNIT OF MEASURE	UNIT PRICE (IN FIGURES) DOLLARS. CENTS	TOTAL AMOUNT DOLLARS. CENTS
1	Mobilization of materials and equipment to and from the project work site.	1	Lump Sum		
2	Prepare and Implement Water Pollution Control Program.	1	Lump Sum		
3	Traffic Control for all project work areas for the duration of the project.	1	Lump Sum		
4	Install 4-inch C900 PVC Pipe in open trench.	30	Linear Feet		
5	Install 8-inch C900 PVC Pipe in open trench.	930	Linear Feet		
6	Install 10-inch C900 PVC Pipe in open trench.	75	Linear Feet		
7	Install 8-inch Gate Valve.	9	Each		
8	Install 10-inch Gate Valve.	4	Each		
9	Install Fire Hydrant Assembly.	3	Each		
10	Install New Water Service Lateral for from the water main to the meter box.	7	Each		
11	Install Meter Box behind the curb and gutter.	7	Each		
12	Complete Intersection Tie-ins for all new water main connections to existing mains.	3	Each		
13	AC Pavement Restoration for all trench repairs	75	Tons		
14	Abandonment of Water Mains	1	Lump Sum		
<b>TOTAL BASE BID</b>					

<b>ADDITIVE BID ITEM 1 - None</b>						
ITEM NO.	CODE NO.	DESCRIPTION OF ITEM	APPROX. QUANTITY	UNIT OF MEASURE	UNIT PRICE (IN FIGURES) DOLLARS. CENTS	TOTAL AMOUNT DOLLARS. CENTS
<b>TOTAL ADDITIVE BID</b>						
<b>GRAND TOTAL BASE BID PLUS ADDITIVE BID ITEMS</b>						

Name of bidder \_\_\_\_\_

Signature of bidder \_\_\_\_\_

Printed Name and Title \_\_\_\_\_

Date \_\_\_\_\_

**DESIGNATION OF SUBCONTRACTORS – BASE BID**

In accordance with the provisions of Public Contract Code section 4100 et seq., the undersigned bidder sets forth the following:

- a. The name, location of the place of business, and California contractor’s license number of each Subcontractor who will perform work or labor, or render service to the undersigned Prime Contractor in or about the construction of the work or improvement, or a Subcontractor licensed by the State of California who, under subcontract to the Prime Contractor, specially fabricates and installs a portion of the work or improvement according to detailed drawings contained in the plans and specifications, in an amount in excess of one-half of one percent of the undersigned Prime Contractor's Total Bid.
- b. The portion of the work which will be done by each such Subcontractor. Only one Subcontractor shall be listed for each such portion. If the Subcontractor is not performing all of the work under the bid item number(s) listed for that Subcontractor, the bidder shall set forth the portion of the work relating to said bid item number(s) that will be done by the Subcontractor.

Bid Item No.	Description of Trade/Portion of Work	Subcontractor Name	License No.	DIR Reg No.**	Business Address	Percent of Total Bid

By: \_\_\_\_\_  
 (Bidder's Company Name)

NOTES: \*When there is a failure to list a Subcontractor as required, or when the bidder lists two Subcontractor for the same portion of the work, the law provides that the bidder agrees that bidder is fully qualified to perform that portion itself, and that the bidder shall perform that portion itself. In such case, bidder must be authorized to perform said work. Any Bid not complying with the provisions hereof may be rejected.

\*\* Pursuant to Labor Code Section 1771.1, no contractor or Subcontractor may be listed on the bid proposal for this public works project unless registered with the Department of Industrial Relations pursuant to Labor Code Section 1725.5.

## DECLARATION OF NONCOLLUSION

In accordance with Public Contract Code Section 7106, the bidder declares as follows:

I am the \_\_\_\_\_ [title] of \_\_\_\_\_ [name] of bidder], the party making the foregoing Bid. The Bid is not made in the interest of, or on behalf of, any undisclosed person, partnership, company, association, organization, or corporation. The Bid is genuine and not collusive or sham. The bidder has not directly or indirectly induced or solicited any other bidder to put in a false or sham Bid. The bidder has not directly or indirectly colluded, conspired, connived, or agreed with any bidder or anyone else to put in a sham Bid, or to refrain from bidding. The bidder has not in any manner, directly or indirectly, sought by agreement, communication, or conference with anyone to fix the bid price of the bidder or any other bidder, or to fix any overhead, profit, or cost element of the Bid price, or of that of any other bidder. All statements contained in the Bid are true. The bidder has not, directly or indirectly, submitted his or her Bid price or any breakdown thereof, or the contents thereof, or divulged information or data relative thereto, to any corporation, partnership, company, association, organization, bid depository, or to any member or agent thereof, to effectuate a collusive or sham bid, and has not paid, and will not pay, any person or entity for such purpose. Any person executing this declaration on behalf of a bidder that is a corporation, partnership, joint venture, limited liability company, limited liability partnership, or any other entity, hereby represents that he or she has full power to execute, and does execute, this declaration on behalf of the bidder.

I declare under penalty of perjury under the laws of the State of California that the foregoing is true and correct and that this declaration is executed on:

\_\_\_\_\_ [date], at \_\_\_\_\_ [city], \_\_\_\_\_ [state].

Signed: \_\_\_\_\_

Print Name: \_\_\_\_\_

If the bidder fails to complete and properly sign this declaration, the Bid will be considered non-responsive and will be rejected.

**PUBLIC CONTRACT CODE SECTION 10162 QUESTIONNAIRE**

The bidder shall complete, under penalty of perjury, the following questionnaire:

Has the bidder, any officer of the bidder, or any employee of the bidder who has a proprietary interest in the bidder, ever been disqualified, removed, or otherwise prevented from bidding on, or completing a federal, state, or local government project because of a violation of law or a safety regulation?

Yes \_\_\_\_\_ No \_\_\_\_\_

If the answer is yes, explain the circumstances in the following space.

---

---

---

---

---

---

---

---

---

---

I declare under penalty of perjury under the laws of the State of California that the foregoing is true and correct.

Company: \_\_\_\_\_

Signed: \_\_\_\_\_

Printed Name: \_\_\_\_\_

Title: \_\_\_\_\_

Date: \_\_\_\_\_



**PUBLIC CONTRACT CODE SECTION 10232 STATEMENT**

The bidder, hereby states under penalty of perjury, that no more than one final unappealable finding of contempt of court by a federal court has been issued against the Contractor within the immediately preceding two-year period because of the bidder's failure to comply with an order of a federal court which orders the bidder to comply with an order of the National Labor Relations Board.

I declare under penalty of perjury under the laws of the State of California that the foregoing is true and correct:

Company: \_\_\_\_\_

Signed: \_\_\_\_\_

Printed Name: \_\_\_\_\_

Title: \_\_\_\_\_

Date: \_\_\_\_\_

**PUBLIC CONTRACT CODE SECTION 10285.1  
STATEMENT**

The bidder hereby declares under penalty of perjury under the laws of the State of California that the bidder has \_\_\_ , has not \_\_\_ been convicted within the preceding three years of any offenses referred to in that section, including any charge of fraud, bribery, collusion, conspiracy, or any other act in violation of any state or Federal antitrust law in connection with the bidding upon, award of, or performance of, any public works contract, as defined in Public Contract Code Section 1101, with any public entity, as defined in Public Contract Code Section 1100, including the Regents of the University of California or the Trustees of the California State University. The term "bidder" is understood to include any partner, member, officer, director, responsible managing officer, or responsible managing employee thereof, as referred to in Section 10285.1.

**Note: The bidder must place a check mark after "has" or "has not" in one of the blank spaces provided (above).**

Bidders are cautioned that making a false certification may subject the certifier to criminal prosecution.

I declare under penalty of perjury under the laws of the State of California that the foregoing is true and correct:

Company: \_\_\_\_\_

Signed: \_\_\_\_\_

Printed Name: \_\_\_\_\_

Title: \_\_\_\_\_

Date: \_\_\_\_\_

**IRAN CONTRACTING ACT CERTIFICATION**

**(Public Contract Code section 2200 et seq.)**

As required by California Public Contract Code section 2204, the Contractor certifies subject to penalty for perjury that the option checked below relating to the Contractor's status regarding the Iran Contracting Act of 2010 (Public Contract Code section 2200 et seq.) is true and correct:

- The Contractor is not:
  - (i) identified on the current list of persons and entities engaging in investment activities in Iran prepared by the California Department of General Services in accordance with subdivision (b) of Public Contract Code section 2203; or
  - (ii) a financial institution that extends, for 45 days or more, credit in the amount of \$20,000,000 or more to any other person or entity identified on the current list of persons and entities engaging in investment activities in prepared by the California Department of General Services in accordance with subdivision (b) of Public Contract Code section 2203, if that person or entity uses or will use the credit to provide goods or services in the energy sector in Iran.
- The County has exempted the Contractor from the requirements of the Iran Contracting Act of 2010 after making a public finding that, absent the exemption, the County will be unable to obtain the goods and/or services to be provided pursuant to the Contract.
- The amount of the Contract payable to the Contractor for work does not exceed \$1,000,000.

Company: \_\_\_\_\_

Signed: \_\_\_\_\_

Printed Name: \_\_\_\_\_

Title: \_\_\_\_\_

Date: \_\_\_\_\_

Note: In accordance with Public Contract Code section 2205, false certification of this form shall be reported to the California Attorney General and may result in civil penalties equal to the greater of \$250,000 or twice the Contract Price, termination of the Contract and/or ineligibility to bid on contracts for three years.

**BIDDER'S BOND**

KNOW ALL BY THESE PRESENTS:

That we, \_\_\_\_\_

\_\_\_\_\_

as Principal, and \_\_\_\_\_

\_\_\_\_\_

as Surety, are held and firmly bound unto the Oceano Community Services District, County of San Luis Obispo, State of California (hereinafter called "District") in the penal sum of Ten Percent (10%) of the total aggregate amount of the base Bid of the Principal above named, submitted by said Principal to the District for the work described below, for the payment of which sum in lawful money of the United States, well and truly to be made, we bind ourselves, our heirs, executors, administrators and successors, jointly and severally, firmly by these presents. In no case shall the liability of the Surety hereunder exceed the sum of \_\_\_\_\_

\_\_\_\_\_ (\$\_\_\_\_\_).

THE CONDITION OF THIS OBLIGATION IS SUCH,

That whereas a bid to District for certain construction specifically described as follows, for which bids are to be opened on \_\_\_\_\_, 20\_\_\_\_, has been submitted by Principal to District for:

**2019 GENERATOR REPLACEMENT PROJECT  
OCEANO, CA  
CONTRACT NO. 2019-01**

NOW, THEREFORE, the penal sum guaranteed by this bond shall be forfeited to the District in the event of any of the following:

- (1) The aforesaid Principal withdraws said bid after the time fixed in the Notice to Bidders for the opening of bids; or,
- (2) Principal fails to provide the District within the time(s) specified in the aforesaid contract documents all of the completed DBE documents required to perfect the Principal's bid before the contract is awarded; or
- (3) Principal fails, within fifteen (15) business days after receipt of written notice that the contract has been awarded to Principal, to enter into a written contract with District, in the prescribed form, in accordance with the bid as accepted, and file with the District the certificates of insurance as stipulated in Article 11 of the General Conditions and the two bonds (in the prescribed forms), one to guarantee faithful performance and the other to guarantee payment for labor and materials.

Surety, for value received, hereby stipulates and agrees that no change, extension of time, alteration or addition to the terms of said contract or to the work to be performed thereunder or the specifications accompanying the same shall in any manner affect its obligations on this bond, and it does hereby waive notice of any such change, extension, alteration, or addition.

In the event suit is brought upon said bond by District and judgment is recovered, the Surety shall pay all costs incurred by District in such suit, including a reasonable attorney's fee to be fixed by the court. Death of the Principal shall not relieve Surety of its obligations hereunder.

IN WITNESS WHEREOF, we have hereunto set our hands and seals on this \_\_\_\_\_

day of \_\_\_\_\_, 20\_\_\_\_\_.

\_\_\_\_\_ (Seal)

\_\_\_\_\_ (Seal)

\_\_\_\_\_ (Seal)

Principal

\_\_\_\_\_ (Seal)

\_\_\_\_\_ (Seal)

\_\_\_\_\_ (Seal)

Surety

\_\_\_\_\_

\_\_\_\_\_

Address

NOTE: Signatures of those executing for Surety must be properly acknowledged.

**OCEANO COMMUNITY SERVICES DISTRICT**  
**NORSWING/PERSHING WATERLINE REPLACEMENT PROJECT**  
**CONSTRUCTION CONTRACT**  
**FOR**  
**OCEANO, CA**  
**CONTRACT NO. 2019-03**

OCEANO COMMUNITY SERVICES DISTRICT

CONSTRUCTION CONTRACT

NORSWING / PERSHING WATERLINE  
REPLACEMENT PROJECT

PROJECT # 2019-03

## TABLE OF CONTENTS

SECTION 1	INCORPORATION OF RECITALS AND DEFINITIONS.....	3
SECTION 2	THE PROJECT. ....	4
SECTION 3	THE CONTRACT DOCUMENTS .....	4
SECTION 4	THE WORK.....	4
SECTION 5	PROJECT TEAM.....	4
SECTION 6	TIME OF COMPLETION. ....	5
SECTION 7	COMPENSATION TO CONTRACTOR. ....	6
SECTION 8	STANDARD OF CARE.....	7
SECTION 9	INDEMNIFICATION. ....	7
SECTION 10	COMPLIANCE WITH APPLICABLE CODE REQUIREMENTS.....	8
SECTION 11	INSURANCE AND BONDS.....	8
SECTION 12	PROHIBITION AGAINST TRANSFERS.....	8
SECTION 13	NOTICES. ....	9
SECTION 14	DISPUTE RESOLUTION.....	10
SECTION 15	DEFAULT.....	13
SECTION 16	DISTRICT'S RIGHTS AND REMEDIES .....	14
SECTION 17	CONTRACTOR'S RIGHTS AND REMEDIES. ....	17
SECTION 18	ACCOUNTING RECORDS. ....	18
SECTION 19	INDEPENDENT PARTIES. ....	18
SECTION 20	NUISANCE.....	18
SECTION 21	PERMITS AND LICENSES. ....	18
SECTION 22	WAIVER.....	19
SECTION 23	CONFLICTS WITH THE CONSTRUCTION CONTRACT. ....	19
SECTION 24	GOVERNING LAW AND VENUE.....	19
SECTION 25	COMPLETE AGREEMENT.....	19
SECTION 26	SURVIVAL OF CONTRACT.....	19
SECTION 27	ADDITIONAL CONTRACT REQUIREMENTS. ....	19
SECTION 28	PUBLIC WORKS CONTRACTOR REGISTRATION PROGAM- SB 854...	20
SECTION 29	GOVERNMENTAL POWERS .....	20
SECTION 30	SEVERABILITY.....	20
SECTION 31	EXHIBITS.....	20



## CONSTRUCTION CONTRACT

THIS CONSTRUCTION CONTRACT entered into on \_\_\_\_\_, 2019 (“Execution Date”) by and between the OCEANO COMMUNITY SERVICES DISTRICT, a California community services district (“District”), and \_\_\_\_\_. (“Contractor”), is made with reference to the following:

### **RECITALS:**

A. District is a community services district duly organized and validly existing under the laws of the State of California with the power to carry on its business as it is now being conducted under the statutes of the State of California.

B. Contractor is a Corporation or company duly organized and in good standing in the State of California, License Number \_\_\_\_\_. Contractor represents that it is duly licensed by the State of California and has the background, knowledge, experience and expertise to perform the obligations set forth in this Construction Contract.

C. On \_\_\_\_\_, District issued a Notice Inviting Bids to contractors for Norswing / Pershing Waterline Replacement Project. A copy of District’s Notice Inviting Bids and Instructions to Bidders is attached hereto as Exhibit “A” and incorporated by reference. In response to District’s Notice Inviting Bids, Contractor submitted its Bid. A copy of Contractor’s Bid is attached hereto as Exhibit “B” and incorporated herein by reference. Also attached hereto and incorporated by reference are the following:

- Exhibit C – General Conditions.
- Exhibit D – Plans and Drawings.
- Exhibit E – Special Provisions and/or Technical Specifications.
- Exhibit F – Reports, Supplements, Attachments, Modifications, and Exhibits attached to the above items including:
  - San Luis Obispo County Encroachment Permit ENC 20190249
- Exhibit G – Insurance Requirements.
- Exhibit H – Performance and Payment Bonds.

D. District and Contractor desire to enter into this Construction Contract for the Norswing / Pershing Waterline Replacement Project, and other services as identified in the Bid Documents for the upon the following terms and conditions.

NOW THEREFORE, in consideration of the mutual promises and undertakings hereinafter set forth and for other good and valuable consideration, the receipt and sufficiency of which are hereby acknowledged, it is mutually agreed by and between the undersigned parties as follows:

## **SECTION 1                    INCORPORATION OF RECITALS AND DEFINITIONS.**

### **1.1      Recitals.**

All of the recitals are incorporated herein by reference.

### **1.2      Definitions.**

Capitalized terms shall have the meanings set forth in this Construction Contract and/or in the General Conditions. If there is a conflict between the definitions in this Construction Contract and in the General Conditions, the definitions in this Construction Contract shall prevail.

## **SECTION 2            THE PROJECT.**

The Project is the construction of the Norswing/Pershing Waterline Replacement Project ("Project").

## **SECTION 3            THE CONTRACT DOCUMENTS.**

The Contract Documents consist of the following collection of documents:

- (i) Executed Construction Contract between District and Contractor.
- (ii) Notice Inviting Bids.
- (iii) Instructions to Bidders.
- (iv) Bidding Addenda.
- (v) Contractor's Bid.
- (vi) General Conditions.
- (vii) Special Provisions and Technical Specifications.
- (viii) Plans and Drawings.
- (ix) Performance and Payment Bonds.
- (x) Insurance Forms.
- (xi) Reports listed in the Bidding Documents.
- (xii) Supplements, Attachments, and Exhibits attached to the above items.
- (xiii) Modifications.
- (xiv) Change Orders.
- (xv) Field Orders.
- (xvi) Other documents as so designated by written agreement of the Parties.

## **SECTION 4            THE WORK.**

The Work includes all labor, materials, equipment, services, permits, licenses and taxes, and all other things necessary for Contractor to perform its obligations and complete the Project, including, without limitation, any Changes requested by District, in accordance with the Contract Documents and all Applicable Code Requirements.

## **SECTION 5            PROJECT TEAM.**

In addition to Contractor, District has retained, or may retain, consultants and contractors to provide professional and technical consultation for the design and construction of the Project. The Project requires that Contractor operate efficiently, effectively and cooperatively with District as well as all other members of the Project Team.

---

**SECTION 6 TIME OF COMPLETION.****6.1 Time Is of the Essence.**

Time is of the essence with respect to all time limits set forth in the Contract Documents.

**6.2 Commencement of Work.**

Contractor shall commence the Work on the date specified in District's Notice to Proceed.

**6.3 Contract Time.**

Contractor shall diligently prosecute the Work to Substantial Completion within 60 Calendar Days after the date specified in District's Notice to Proceed.

**6.4 Liquidated Damages.****6.4.1 Entitlement.**

District and Contractor acknowledge and agree that if Contractor fails to fully and satisfactorily complete the Work within the Contract Time, District will suffer, as a result of Contractor's failure, substantial damages which are both extremely difficult and impracticable to ascertain. Such damages may include, but are not limited to:

- (i) Loss of public confidence in District and its contractors and consultants.
- (ii) Loss of public use of public facilities.
- (iii) Extended disruption to public.

**6.4.2 Daily Amount.**

District and Contractor have reasonably endeavored, but failed, to ascertain the precise amount in relation to the actual damage that District will incur if Contractor fails to achieve Substantial Completion of the entire Work within the Contract Time. Therefore, the parties agree that in addition to all other damages to which District may be entitled, in the event Contractor shall fail to achieve Substantial Completion of the entire Work within the Contract Time, Contractor shall pay District as liquidated damages the amount of \$250.00 per day for each Day occurring after the expiration of the Contract Time until Contractor achieves Substantial Completion of the entire Work. The liquidated damages amount is not a penalty but considered to be a reasonable estimate of the amount of damages District will suffer.

**6.4.3 Apportionment.**

Such liquidated damages shall be subject to apportionment for delays to Substantial Completion for which Contractor is entitled to receive an extension of time under the Contract Documents. Such apportionment shall not be affected by the fact that liquidated damages may not be capable of apportionment for other periods of time during which there have occurred delays concurrently caused by both District and Contractor. It being the Contractor's obligation to have the entire Work Substantially Completed within the Contract Time, it is agreed that such liquidated damages shall not be apportioned for portions of the Work completed prior to expiration of the Contract Time.

**6.4.4 Damages upon Abandonment.**

In the event that Contractor either abandons the Work or is terminated for default in accordance with the provisions of Section 15 of this Construction Contract, District shall have the right to liquidated damages pursuant to Paragraph 6.4 in addition to all actual Losses proximately resulting from Contractor's failure to complete the Work within the Contract Time.

**6.4.5 Other Remedies.**

The parties further acknowledge and agree that District is entitled to any and all available legal and equitable remedies District may have where District's Losses are caused by any reason other than Contractor's failure to achieve Substantial Completion of the entire Work within the Contract Time.

**6.5 Adjustments to Contract Time.**

The Contract Time may only be adjusted for time extensions approved by District and agreed to by Change Order executed by District and Contractor in accordance with the requirements of the Contract Documents.

**6.6 Additional Compensation to Contractor.**

The Contract Sum shall be increased by the amount of \$250.00 for each day of extension to the Contract Time that is permitted under the terms of the General Conditions solely due to Compensable Delay occurring prior to Substantial Completion, but only to the extent that such Compensable Delay is not concurrent with a Non-Compensable Delay.

Regardless of the cause of the Delay (including, without limitation, acts or omissions of District or its consultants, errors, conflicts or omissions in the Contract Documents, or Changes to the Work), Contractor agrees to accept the compensation provided for in this Paragraph as its sole and exclusive right, remedy and recovery arising from or related to any Delay, interruption, hindrance, compression, acceleration, disruption or the impact or ripple effect of Delays on the Work, that may occur in connection with Contractor's performance of Work on the Project and for any resulting foreseen or unforeseen:

- (i) Overhead expenses such as, but not limited to, additional supervision, administration, extended or extraordinary overhead (direct or home office), insurance or bond costs; and
- (ii) Productivity expenses such as additional loss of productivity, inefficiency, and escalation of costs of labor, wage, material or equipment.

**SECTION 7 COMPENSATION TO CONTRACTOR.****7.1 Contract Sum.**

Contractor shall be compensated for satisfactory completion of the Work in compliance with the Contract Documents the Contract Sum of \_\_\_\_\_ Dollars (\$ \_\_\_\_\_).

**7.2 Full Compensation.**

The Contract Sum shall be full compensation for all Work provided by Contractor and, except as otherwise expressly permitted by the terms of the Contract Documents, shall cover all Losses arising out of the nature of the Work or from the acts of the elements or \_\_\_\_\_ any unforeseen difficulties or obstructions which may arise or be encountered in

performance of the Work until its Acceptance by District, all risks connected with the Work, and any and all expenses incurred due to suspension or discontinuance of the Work. The Contract Sum may only be adjusted for Change Orders issued, executed and satisfactorily performed in accordance with the requirements of the Contract Documents.

### **7.3 Compensation for Extra or Deleted Work.**

The Contract Sum shall be adjusted (either by addition or credit) for Changes in the Work involving Extra Work or Deleted Work on the basis of both of the following:

- (i) The sum of Allowable Costs as defined in Paragraph 7.2.5 of the General Conditions to be added (for Extra Work) or credited (for Deleted Work); and
- (ii) An additional sum (for Extra Work) or deductive credit (for Deleted Work) based on Contractor Markup and Subcontractor/Sub-subcontractor Markups allowable pursuant to this Section 7.3.

Contractor Markup and Subcontractor/Sub-subcontractor Markups set forth herein are the full amount of compensation to be added for Extra Work or to be subtracted for Deleted Work that is attributable to overhead (direct and indirect) and profit of Contractor and of its Subcontractors and Sub-subcontractors, of every Tier. Contractor Markup and Subcontractor/Sub-subcontractor Markups, which shall not be compounded, shall be computed as follows:

#### **7.3.1 Self-Performed Work.**

Fifteen percent (15%) of the Allowable Costs for that portion of the Extra Work or Deleted Work to be performed by Contractor with its own forces.

#### **7.3.2 Subcontractors.**

15% of the Allowable Costs for that portion of the Extra Work or Deleted Work to be performed by a first Tier Subcontractor with its own forces, plus 2.5% thereon for Contractor Markup.

#### **7.3.3 Sub-subcontractors.**

15% of the Allowable Costs of that portion of the Work to be performed by Sub-subcontractors of the second and lower Tier with their own forces, plus 2.5% thereon for the Subcontractor, plus 2.5% on the combined total thereof for Contractor Markup.

## **SECTION 8 STANDARD OF CARE.**

Contractor agrees that the Work shall be performed by qualified, experienced and well-supervised personnel. All services performed in connection with this Construction Contract shall be performed in a manner consistent with the standard of care under California law applicable to those who specialize in providing such services for projects of the type, scope and complexity of the Project.

## **SECTION 9 INDEMNIFICATION.**

### **9.1 Hold Harmless.**

To the fullest extent allowed by law, Contractor hereby agrees to defend, indemnify, and hold harmless District, its District Board of Directors, officers, agents, employees,

representatives and volunteers (hereinafter collectively referred to as "Indemnitees"), through legal counsel acceptable to District, from and against any and all Losses, claims, causes of action arising directly or indirectly from, or in any manner relating to any of, the following:

- (i) Performance or nonperformance of the Work by Contractor or its Subcontractors or Sub-subcontractors, of any Tier;
- (ii) Performance or nonperformance by Contractor or its Subcontractors or Sub-subcontractors, of any Tier, of any of the obligations under the Contract Documents;
- (iii) The construction activities of Contractor or its Subcontractors or Sub-subcontractors, of any Tier, either on the Site or on other properties;
- (iv) The payment or nonpayment by Contractor of any of its Subcontractors or Sub-subcontractors, of any Tier, for Work performed on or off the Site for the Project; and
- (v) Any personal injury, including but not limited to bodily injury or death, arising out of or relating to the performance or non-performance of the Work.
- (vi) Any injury, property damage or economic loss to third parties associated with the performance or nonperformance by Contractor or its Subcontractors or Sub-subcontractors, of any Tier, of the Work.

However, nothing contained herein shall be construed as obligating Contractor to indemnify any Indemnatee for Losses resulting from the sole or active negligence or willful misconduct of the Indemnatee. Contractor shall pay District for any costs incurred in enforcing this provision. Nothing in the Contract Documents shall be construed to give rise to any implied right of indemnity in favor of Contractor against District or any other Indemnatee.

## **9.2 Survival.**

The provisions of Section 9 shall survive the termination of this Construction Contract.

## **SECTION 10 COMPLIANCE WITH APPLICABLE CODE REQUIREMENTS.**

This Project constitutes "public works" within the meaning of California Labor Code section 1720 and is subject to the prevailing wage laws. Contractor agrees to be subject to and comply with all applicable federal, state and municipal laws, codes, ordinances and regulations governing the Work, including, but not limited to applicable provisions of the California Labor Code.

## **SECTION 11 INSURANCE AND BONDS.**

Prior to the commencement of any Work, Contractor shall provide District with evidence that it has obtained insurance and Performance and Payment Bonds satisfying all requirements in Article 11 of the General Conditions. Failure to do so shall be deemed a material breach of this Construction Contract.

## **SECTION 12 PROHIBITION AGAINST TRANSFERS.**

District is entering into this Construction Contract based upon the stated experience and qualifications set forth in Contractor's Bid. Accordingly, Contractor shall not assign, hypothecate or transfer this Construction Contract or any interest therein directly or indirectly, by operation of law or otherwise without the prior written consent of District. Any assignment, hypothecation

or transfer without said consent shall be null and void.

For purposes of applying the provisions of this Section, the sale, assignment, transfer or other disposition of any of the issued and outstanding capital stock of Contractor or of any general partner or joint venture or syndicate member of Contractor, if a partnership or joint venture or syndicate or co-tenancy exists, which shall result in changing the control of Contractor, shall be construed as an assignment of this Construction Contract. Control means more than fifty percent (50%) of the voting power of the corporation or other entity.

## **SECTION 13           NOTICES.**

### **13.1 Method of Notice.**

Except as provided in Section 13.2 below, all notices, demands, requests or approvals to be given under this Construction Contract shall be given in writing and conclusively shall be deemed served on the earlier of the following:

- (i) On the date delivered, if delivered personally;
- (ii) On the third business day after the deposit thereof in the United States mail, postage prepaid, and addressed as hereinafter provided;
- (iii) On the date sent, if sent by facsimile transmission; or
- (iv) On the date it is accepted or rejected, if sent by certified mail.

### **13.2 Notice Recipients.**

All notices, demands or requests (including, without limitation, Claims) from Contractor to District at:

Oceano Community Services District  
1655 Front Street  
Oceano, CA 93455  
Attn: General Manager

In addition, copies of all Claims by Contractor under this Construction Contract shall be provided to the following:

Jeffery A. Minnery  
P.O. Box 3835  
San Luis Obispo, CA 93403-3835

All Claims shall be delivered personally or sent by certified mail.

All notices, demands, requests or approvals from District to Contractor shall be addressed to:

Contractor contact information:

\_\_\_\_\_

**13.3 Change of Address.**

In the event of any change of address, the moving party is obligated to notify the other party of the change of address in writing. Each party may, by written notice only, add, delete or replace any listed individuals.

**SECTION 14 DISPUTE RESOLUTION.****14.1 Resolution of Contract Disputes.**

Contractor Claims (as defined by Public Contract Code Section 9204(c)) and General Conditions Section 1.1.18 shall be resolved by the parties in accordance with General Conditions Section 4.2 and applicable law. The procedures set forth in General Conditions Section 4.2 shall be the exclusive recourse of Contractor for such claims.

**14.2 Resolution of Other Disputes.****14.2.1 Other Disputes.**

The definition of Contractor Claims shall not include any of the following:

- (i) Penalties or forfeitures prescribed by statute or regulation imposed by a governmental agency (other than relief from damages or penalties for delay assessed by a public entity under a contract for a public works project);
- (ii) Third party tort claims for personal injury, property damage or death relating to any Work performed by Contractor or its Subcontractors or Sub-subcontractors of any Tier;
- (iii) False claims liability under California Government Code Section 12650, et. seq.;
- (iv) Defects in the Work first discovered by District after Final Payment by District to Contractor; or
- (vi) The right of District to specific performance or injunctive relief to compel performance of any provision of the Contract Documents or for other District claims against the Contractor.

**14.2.2 Litigation, District Election.**

Matters that do not constitute Contractor Claims shall be resolved by way of an action filed in the Superior Court of the State of California, County of San Luis Obispo, and shall not be subject to the Contract Dispute Resolution Process. However, the District reserves the right, in its sole and absolute discretion, to treat such disputes as Contract Disputes.

Upon written notice by District of its election as provided in the preceding sentence, such dispute shall be submitted by the parties and finally decided pursuant to the Contract Dispute Resolution Process in the manner as required for Contract Disputes, including, without limitation, District's right under Paragraph 14.4.2 to defer resolution and final determination until after Final Completion of the Work.

**14.3 Submission of Contractor Claim.****14.3.1 By Contractor.**

Contractor shall submit a written Contractor Claim in accordance with Section 4.2 of the General Conditions.



**14.3.2 By District.**

District's right to commence the Contract Dispute Resolution Process shall arise at any time following District's actual discovery of the circumstances giving rise to the Contract Dispute. Nothing contained herein shall preclude District from asserting Contract Disputes in response to a Claim asserted by Contractor. A Statement of Contract Dispute submitted by District shall state the events or circumstances giving rise to the Contract Dispute, the dates of their occurrence and the damages or other relief claimed by District as a result of such events.

**14.4 Contract Dispute Resolution Process.**

The parties shall utilize each of the following steps in the Contract Dispute Resolution Process in the sequence they appear below. Each party shall participate fully and in good faith in each step in the Contract Dispute Resolution Process, which good faith effort shall be a condition precedent to the right of each party to proceed to the next step in the process.

**14.4.1 Response by District.**

The time periods for the District's response are set forth in General Conditions Section 4.2.6; however, any failure to respond shall be governed by General Condition Section 4.2.9.

**14.4.2 Meet and Confer Conference.**

If the claimant disputes the District's written response, or if the District fails to respond to a claim issued within the time prescribed in General Conditions Section 4.2, the claimant may demand in writing an informal conference to meet and confer for settlement of the issue in dispute. Upon receipt of a demand in writing sent by registered mail or certified mail, return receipt requested, the District shall schedule a meet and confer conference within 30 days for settlement of the dispute.

**14.4.3 Mediation.**

(i) Within ten (10) business days following the conclusion of the meet and confer conference, if the claim or any portion of the claim remains in dispute, the District shall provide the claimant a written statement identifying the portion of the claim that remains in dispute and the portion that is undisputed. Any payment due on an undisputed portion of the claim shall be processed and made within sixty (60) days after the public entity issues its written statement. Any disputed portion of the claim, as identified by the contractor in writing, shall be submitted to nonbinding mediation, with the District and the claimant sharing the associated costs equally.

The District and the claimant shall mutually agree to a mediator within ten (10) business days after the disputed portion of the claim has been identified in writing. If the parties cannot agree upon a mediator, each party shall select a mediator and those mediators shall select a qualified neutral third party to mediate with regard to the disputed portion of the claim. Each party shall bear the fees and costs charged by its respective mediator in connection with the selection of the neutral mediator. If mediation is unsuccessful, the parts of the claim remaining in dispute shall be subject to applicable procedures outside this section.

(ii) For purposes of this section, mediation includes any nonbinding process, including, but not limited to, neutral evaluation or a dispute review board,

in which an independent third party or board assists the parties in dispute resolution through negotiation or by issuance of an evaluation. Any mediation utilized shall conform to the timeframes in this section.

(iii) Unless otherwise agreed to by the District and the contractor in writing, the mediation conducted pursuant to this section shall excuse any further obligation under Public Contract Code Section 20104.4 to mediate after litigation has been commenced.

#### **14.4.4 Binding Arbitration.**

If the Contract Dispute is not resolved by mediation, then the party wishing to further pursue resolution or determination of the Contract Dispute shall submit the Contract Dispute for final and binding arbitration pursuant to the provisions of California Public Contract Code Sections 10240, et seq. The award of the arbitrator therein shall be final and may be entered as a judgment by any court of competent jurisdiction. Such arbitration shall be conducted in accordance with the following:

- .1 Arbitration Initiation.** The arbitration shall be initiated by filing a complaint in arbitration in accordance with the regulations promulgated pursuant to California Public Contract Code Section 10240.5.
- .2 Qualifications of the Arbitrator.** The arbitrator shall be selected based by mutual agreement of the parties. The arbitrator shall be a retired judge or an attorney with at least five (5) years of experience with public works construction contract law and in arbitrating public works construction disputes. In addition, the arbitrator shall have at least twenty (20) hours of formal training in arbitration skills. In the event the parties cannot agree upon a mutually acceptable arbitrator, then the provisions of California Public Contract Code Section 10240.3 shall be followed in selecting an arbitrator possessing the qualifications required herein.
- .3 Hearing Days and Location.** Arbitration hearings shall be held at the offices of District and shall, except for good cause shown to and determined by the arbitrator, be conducted on consecutive business days, without interruption or continuance.
- .4 Hearing Delays.** Arbitration hearings shall not be delayed except upon good cause shown.
- .5 Recording Hearings.** All hearings to receive evidence shall be recorded by a certified stenographic reporter, with the costs thereof borne equally by District and Contractor and allocated by the arbitrator in the final award.
- .6 Limitation of Depositions.** Discovery shall be permitted in accordance with the provisions of section 10240.11 of the Public Contract Code; provided, however, that depositions shall be limited to both of the following:
  - (i) Ten (10) percipient witnesses for District and ten (10) percipient witnesses for Contractor; and
  - (ii) Expert witnesses.

Upon a showing of good cause, the arbitrator may increase the number of permitted depositions. An individual who is both percipient and expert shall, for purposes of applying the foregoing numerical limitation only, be deemed an expert. Expert reports shall be exchanged prior to receipt of evidence, in accordance with the direction of the arbitrator, and expert reports (including initial and rebuttal reports) not so submitted shall not be admissible as evidence

- .7 Authority of the Arbitrator.** The arbitrator shall have the authority to hear dispositive motions and issue interim orders and interim or executory awards.
- .8 Waiver of Jury Trial.** Contractor and District each voluntarily waives its right to a jury trial with respect to any Contract Dispute that is subject to binding arbitration in accordance with the provisions of this Paragraph 14.4.4. Contractor shall include this provision for waiver of jury trial, waiving the right to jury trial in any action involving District as a party in its contracts with its Subcontractors who provide any portion of the Work.

#### **14.5 Non-Waiver.**

There shall be no waiver of the rights granted pursuant to the Dispute Resolution Process, unless specifically set forth in Public Contract Code Section 9204((f)(1) or (2). Specifically, participation in the Contract Dispute Resolution Process shall not constitute a waiver, release or compromise of any defense of District, including, without limitation, any defense based on the assertion that the rights or Claims of Contractor that are the basis of a Contract Dispute were previously waived by Contractor due to failure to comply with the Contract Documents, including, without limitation, Contractor's failure to comply with any time periods for providing notice of requests for adjustments of the Contract Sum or Contract Time or for submission of Claims or supporting documentation of Claims.

## **SECTION 15            DEFAULT.**

### **15.1 Notice of Default.**

In the event that District determines, in its sole discretion, that Contractor has failed or refused to perform any of the obligations set forth in the Contract Documents, or is in breach of any provision of the Contract Documents, District may give written notice of default to Contractor in the manner specified for the giving of notices in the Construction Contract.

### **15.2 Opportunity to Cure Default.**

Except for emergencies, Contractor shall cure any default in performance of its obligations under the Contract Documents within two (2) Days after receipt of written notice. However, if the breach cannot be reasonably cured within such time, Contractor will commence to cure the breach within two (2) Days and will diligently and continuously prosecute such cure to completion within a reasonable time, which shall in no event be later than ten (10) Days after receipt of such written notice.

## **SECTION 16            DISTRICT'S RIGHTS AND REMEDIES.**

**16.1 Remedies Upon Default.**

In the event that Contractor fails to cure any default of this Construction Contract within the time period set forth above in Section 15, then District may pursue any remedies available under law or equity, including, without limitation, the following:

**16.1.1 Delete Certain Services.**

District may, without terminating the Construction Contract, delete certain portions of the Work, reserving to itself all rights to Losses related thereto.

**16.1.2 Perform and Withhold.**

District may, without terminating the Construction Contract, engage others to perform the Work or portion of the Work that has not been performed by Contractor and withhold the cost thereof to District from future payments to Contractor, reserving to itself all rights to Losses related thereto.

**16.1.3 Suspend the Construction Contract.**

District may, without terminating the Construction Contract and reserving to itself all rights to Losses related thereto, suspend all or any portion of this Construction Contract for as long a period of time as District determines, in its sole discretion, appropriate, in which event District shall have no obligation to adjust the Contract Sum or Contract Time, and shall have no liability to Contractor for damages if District directs Contractor to resume Work.

**16.1.4 Terminate the Construction Contract for Default.**

District may terminate all or any part of this Construction Contract for default in accordance with Paragraph 16.4 below, reserving to itself all rights to Losses related thereto and any other damages proximately caused or resulting from the Default.

**16.1.5 Invoke the Performance Bond.**

District may, with or without terminating the Construction Contract and reserving to itself all rights to Losses related thereto, exercise its rights under the Performance Bond.

**16.1.6 Additional Provisions.**

All of District's rights and remedies under this Construction Contract are cumulative, and shall be in addition to those rights and remedies available in law or in equity. Designation in the Contract Documents of certain breaches as material shall not be construed as implying that other breaches not so designated are not material nor shall such designations be construed as limiting District's right to terminate the Construction Contract, or the exercise of its other rights or remedies for default, to only material breaches. District's determination of whether there has been noncompliance with the Construction Contract so as to warrant exercise by District of its rights and remedies for default under the Construction Contract, shall be binding on all parties. No termination or action taken by District after such termination shall prejudice any other rights or remedies of District provided by law or equity or by the Contract Documents upon such termination; and District may proceed against Contractor to recover all liquidated damages and Losses suffered by District.

**16.2 Delays by Sureties.**

---

Without limitation to any of District's other rights or remedies under the law, District has the

(iv) Construction Contract

Contract No. 2019-03  
(Norswing/Pershing Waterline)

right to suspend the performance by Contractor's sureties in the event of any of the following:

- (i) Failure of the sureties to begin Work within a reasonable time in such manner as to insure full compliance with the Construction Contract within the Contract Time;
- (ii) Abandonment of the Work;
- (iii) If at any time District is of the opinion the Work is unnecessarily or unreasonably delayed;
- (iv) Willful violation of any terms of the Construction Contract;
- (v) Failure to perform according to the Contract Documents; or
- (vi) Failure to follow instructions of District for its completion within the Contract Time.

District will serve notice of such failure upon the sureties and in the event the sureties neglect or refuse to cure the breach within the time specified in such notice, District shall have the power to suspend the performance or any part thereof of the sureties.

### **16.3 Damages to District.**

#### **16.3.1 For Contractor's Default.**

District will be entitled to recovery of all Losses under law or equity in the event of Contractor's default under the Contract Documents.

#### **16.3.2 Compensation for Losses.**

In the event that District's Losses arise from Contractor's default under the Contract Documents, District shall be entitled to withhold monies otherwise payable to Contractor until Final Completion of the Project. If District incurs Losses due to Contractor's default, then the amount of Losses shall be deducted from the amounts withheld. Should the amount withheld exceed the amount deducted, the balance will be paid to Contractor or its designee upon Final Completion of the Project. If the Losses incurred by District exceed the amount withheld, Contractor shall be liable to District for the difference and shall promptly remit same to District.

### **16.4 Termination of the Construction Contract for Default.**

Without limitation to any of District's other rights or remedies at law or in equity, and reserving to itself all rights to Losses related thereto, District shall have the right to terminate this Construction Contract, in whole or in part, upon the failure of Contractor to promptly cure any default as required by Section 15. District's election to terminate the Construction Contract for default shall be communicated by giving Contractor a written notice of termination in the manner specified for the giving of notices in the Construction Contract. Any notice of termination given to Contractor by District shall be effective immediately, unless otherwise provided therein.

### **16.5 Suspension by District for Convenience.**

District may, at any time and from time to time, without cause, order Contractor, in writing, to suspend, delay, or interrupt the Work in whole or in part for such period of time, up to an aggregate of fifty percent (50%) of the Contract Time, as District may determine, with such period of suspension to be computed from the date of the written order. Such order shall be specifically identified as a Suspension Order by District. Upon receipt of a Suspension Order, Contractor shall, at District's expense, comply with its terms and take all reasonable steps to minimize costs allocable to the Work covered by the Suspension Order during the period of Work stoppage. Within the period of the above noted aggregate time, or such extension to that period as is agreed upon by Contractor and District, District

shall either cancel the Suspension Order or delete the Work covered by such Suspension Order by issuing a Change Order. If a Suspension Order is canceled or expires, Contractor shall resume and continue with the Work. A Change Order will be issued to cover any adjustments of the Contract Sum or the Contract Time necessarily caused by such suspension. The provisions of this Paragraph 16.5 shall not apply if a Suspension Order is not issued by District. A Suspension Order shall not be required to stop the Work as permitted or required under any other provision of the Contract Documents.

## **16.6 Termination Without Cause.**

District shall have the option, at its sole discretion and without cause, of terminating this Construction Contract in part or in whole by giving thirty (30) Days written notice to Contractor. Contractor agrees to accept such sums as allowed under this Paragraph 16.6 as its sole and exclusive compensation and waives any claim for other compensation or Losses, including, but not limited to, loss of anticipated profits, loss of revenue, lost opportunity, or other consequential, direct, indirect or incidental damages of any kind.

### **16.6.1 Compensation.**

Following such termination and within forty-five (45) Days after receipt of a billing from Contractor seeking payment of sums authorized by this Paragraph 16.6, District shall pay to Contractor as its sole compensation for performance of the Work the following:

- .1 For Work Performed.** The amount of the Contract Sum allocable to the portion of the Work properly performed by Contractor as of the date of termination, less sums previously paid to Contractor.
- .2 For Close-out Costs.** Reasonable costs of Contractor and its Subcontractors and Sub-subcontractors for:
  - (i) Demobilizing and
  - (ii) Administering the close-out of its participation in the Project (including, without limitation, all billing and accounting functions, not including attorney or expert fees) for a period of no longer than thirty (30) Days after receipt of the notice of termination in an amount not to exceed the daily sum payable to Contractor for Compensable Delays in Paragraph 6.6 of this Construction Contract.
- .3 For Fabricated Items.** Previously unpaid cost of any items delivered to the Project Site which were fabricated for subsequent incorporation in the Work.

### **16.6.2 Subcontractors.**

Contractor shall include provisions in all of its subcontracts, purchase orders and other contracts permitting termination for convenience by Contractor on terms that are consistent with this Construction Contract and that afford no greater rights of recovery against Contractor than are afforded to Contractor under this Section 16.6.

## **16.7 Contractor's Duties Upon Termination.**

Upon receipt of a notice of termination for default or for convenience, Contractor shall, unless the notice directs otherwise, do the following:

- (i) Immediately discontinue the Work to the extent specified in the notice;
- (ii) Place no further orders or subcontracts for materials, equipment, services or

- facilities, except as may be necessary for completion of such portion of the Work as is not discontinued;
- (iii) Provide to District a description, in writing no later than fifteen (15) days after receipt of the notice of termination, of all subcontracts, purchase orders and contracts that are outstanding, including, without limitation, the terms of the original price, any changes, payments, balance owing, the status of the portion of the Work covered and a copy of the subcontract, purchase order or contract and any written changes, amendments or modifications thereto, together with such other information as District may determine necessary in order to decide whether to accept assignment of or request Contractor to terminate the subcontract, purchase order or contract;
  - (iv) Promptly assign to District those subcontracts, purchase orders or contracts, or portions thereof, that District elects to accept by assignment and cancel, on the most favorable terms reasonably possible, all subcontracts, purchase orders or contracts, or portions thereof, that District does not elect to accept by assignment; and
  - (v) Hereafter do only such Work as may be necessary to preserve and protect Work already in progress and to protect materials, plants, and equipment on the Project Site or in transit thereto.

## **SECTION 17            CONTRACTOR'S RIGHTS AND REMEDIES.**

### **17.1 Contractor's Remedies.**

Contractor may terminate this Construction Contract for cause only upon the occurrence of one of the following:

#### **17.1.1 For Work Stoppage.**

The Work is stopped for sixty (60) consecutive Days, through no act or fault of Contractor, any Subcontractor, or any employee or agent of Contractor or any Subcontractor, due to issuance of an order of a court or other public authority other than District having jurisdiction or due to an act of government, such as a declaration of a national emergency making material unavailable.

#### **17.1.2 For District's Non-Payment.**

If District does not make payment, of sums that are not in good faith disputed by District, and does not cure such default within ninety (90) Days after receipt of notice from Contractor, then upon an additional thirty (30) Days' notice to District, Contractor may terminate the Construction Contract.

### **17.2 Damages to Contractor.**

In the event of termination for cause by Contractor, District shall pay Contractor the sums provided for in Paragraph 16.6 above. Contractor agrees to accept such sums as its sole and exclusive compensation and agrees to waive any claim for other compensation or Losses, including, but not limited to, loss of anticipated profits, loss of revenue, lost opportunity, or other consequential, direct, indirect and incidental damages, of any kind.

## **SECTION 18            ACCOUNTING RECORDS.**

### **18.1 Financial Management and District Access.**

(iv) Construction Contract

Contract No. 2019-03  
(Norswing/Pershing Waterline)

Contractor shall keep full and detailed accounts and exercise such controls as may be necessary for proper financial management under this Construction Contract in accordance with generally accepted accounting principles and practices consistently applied. District and District's accountants shall be afforded access at all times during normal business hours, to inspect, audit and copy Contractor's records, books, estimates, take-offs, cost reports, ledgers, schedules, correspondence, instructions, drawings, receipts, subcontracts, purchase orders, vouchers, memoranda and other data relating to this Project, and Contractor shall preserve these for a period of three (3) years after the later of (i) final payment or (ii) final resolution of all Contract Disputes and other disputes or for such longer period as may be required by law.

#### **18.2 Compliance with District Requests.**

Contractor's compliance with any request by District pursuant to this Section 18 shall be a condition precedent to filing or maintenance of any legal action or proceeding by Contractor against District and to Contractor's right to receive further payments under the Contract Documents. Any failure by Contractor to provide access to its business records for inspection or copying by District shall be specifically enforceable by issuance of a writ or a provisional or permanent mandatory injunction by a court of competent jurisdiction based on affidavits submitted to such court, without the necessity of oral testimony.

### **SECTION 19 INDEPENDENT PARTIES.**

Both parties to this Construction Contract will be acting in an independent capacity and not as agents, employees, partners, or joint venturers of one another. District, its officers or employees shall have no control over the conduct of Contractor or its respective agents, employees, subconsultants, or subcontractors, except as herein set forth.

### **SECTION 20 NUISANCE.**

Contractor shall not maintain, commit, nor permit the maintenance or commission of any nuisance in connection with the performance of services under this Construction Contract.

### **SECTION 21 PERMITS AND LICENSES.**

Contractor, at its sole expense, shall obtain and maintain during the term of this Construction Contract, all appropriate permits, licenses, and certificates that may be required in connection with the performance of services hereunder.

### **SECTION 22 WAIVER.**

A waiver by District of any breach of any term, covenant, or condition contained herein shall not be deemed to be a waiver of any subsequent breach of the same or any other term, covenant, or condition contained herein, whether of the same or a different character.

### **SECTION 23 CONFLICTS WITH THE CONSTRUCTION CONTRACT.**



District and Contractor agree that if there is any conflict between the terms of this Construction Contract and the other Contract Documents, this Construction Contract shall control.

**SECTION 24                    GOVERNING LAW AND VENUE.**

This Construction Contract shall be construed in accordance with and governed by the laws of the State of California. Any and all legal proceedings, including but not limited to mediations, arbitrations, and/or Civil Actions shall be commenced and maintained in the County of San Luis Obispo.

**SECTION 25                    COMPLETE AGREEMENT.**

This Construction Contract represents the full and complete understanding of every kind or nature between the parties with respect to the services set forth in this Construction Contract, and all preliminary negotiations and contracts of whatever kind or nature are merged herein. No verbal agreed or implied covenant shall be held to vary the provisions of this Construction Contract. Any modification of this Construction Contract will be effective only upon written execution signed by both District and Contractor and approved as to form by District Legal Counsel.

**SECTION 26                    SURVIVAL OF CONTRACT.**

The provisions of the Construction Contract which by their nature survive termination of the Construction Contract or Final Completion, including, without limitation, all warranties, indemnities, payment obligations, and District's right to audit Contractor's books and records, shall remain in full force and effect after Final Completion or any termination of the Construction Contract.

**SECTION 27                    ADDITIONAL CONTRACT REQUIREMENTS.**

**This contract ( does or  does not) have special fund(s) involved requiring additional contract requirements, therefore this section ( does or  does not) apply.**

This Contract includes the following source of fund(s) or the District intends to apply to the following source of fund(s) for reimbursement of the expenses associated with the work set forth in this Contract:

N/A

**This contract ( does or  does not) have permit(s) obtained by the District, or which the contractor must obtain, requiring additional contract requirements, therefore this section ( does or  does not) apply.**

This Contract includes the following permits that that the contractor must comply with and/or obtain:

- County of San Luis Obispo Encroachment Permit ENC 20190249.

District shall require Contractor to comply with the special requirements (Exhibit "I"), as they may be amended from time to time, in addition to all other requirements imposed by District.

## **SECTION 28 PUBLIC WORKS CONTRACTOR REGISTRATION PROGRAM- SB 854**

In accordance with State of California Senate Bill No. 854 (SB 854):

- No contractor or subcontractor may be listed on a bid proposal for a public works project (submitted on or after March 1, 2015) unless registered with the Department of Industrial Relations pursuant to Labor Code section 1725.5 [with limited exceptions from this requirement for bid purposes only under Labor Code section 1771.1(a)].
- No contractor or subcontractor may be awarded a contract for public work on a public works project (awarded on or after April 1, 2015) unless registered with the Department of Industrial Relations pursuant to Labor Code section 1725.5.
- This project is subject to compliance monitoring and enforcement by the Department of Industrial Relations.

As of April 1, 2015, contractors and subcontractors must furnish electronic certified payroll records to the Labor Commissioner (State of California, Division of Labor Standards Enforcement).

Please see the DIR website for complete details and actions. It is the responsibility of the contractor to ensure all DIR requirements and regulations are met and stay current. For more information on Senate Bill No. 854, see <http://www.dir.ca.gov/Public-Works/SB854.html>.

## **SECTION 29 GOVERNMENTAL POWERS.**

Nothing in this Agreement shall be deemed directly or indirectly to restrict or to impair in any manner or respect whatsoever any of District's governmental powers or rights or the exercise thereof by District, with respect to the Work or Project.

## **SECTION 30 SEVERABILITY.**

In case a provision of this Construction Contract is held to be invalid, illegal or unenforceable, the validity, legality and enforceability of the remaining provisions shall not be affected.

## **SECTION 31 EXHIBITS.**

- Exhibit A - Notice Inviting Bids.
- Exhibit B - Contractor's Bid.
- Exhibit C - General Conditions.
- Exhibit D - Special Provisions and/or Technical Specifications.
- Exhibit E - Plans and Drawings.

- Exhibit F - Payment and Performance Bonds.
- Exhibit G - Insurance Requirements.
- Exhibit H - Rules Governing Bid Protests
- Exhibit I - San Luis Obispo County Encroachment Permit ENC 20190249

IN WITNESS WHEREOF, the parties have caused this Construction Contract to be executed the date and year first above written.

**OCEANO COMMUNITY SERVICES DISTRICT**

BY: \_\_\_\_\_  
OCSD President

DATE: \_\_\_\_/\_\_\_\_/ 2019

Approved as to FORM:

BY: \_\_\_\_\_  
OCSD Legal Counsel

DATE: \_\_\_\_/\_\_\_\_/ 2019

BY: \_\_\_\_\_  
Contractor

DATE: \_\_\_\_/\_\_\_\_/ 2019

**OCEANO COMMUNITY SERVICES DISTRICT**  
**NORSWING/PERSHING WATERLINE REPLACEMENT PROJECT**  
**GENERAL CONDITIONS**  
**FOR**  
**OCEANO, CA**  
**CONTRACT NO. 2019-03**

OCEANO COMMUNITY SERVICES DISTRICT

STANDARD CONSTRUCTION CONTRACT GENERAL  
CONDITIONS

## GENERAL CONDITIONS TABLE OF CONTENTS

<b>ARTICLE 1 – GENERAL PROVISIONS .....</b>	<b>5</b>
1.1    DEFINITIONS.....	5
1.2    OWNERSHIP AND USE OF DOCUMENTS .....	15
1.3    AUTHORITY OF DISTRICT.....	16
1.4    INTERPRETATION OF CONTRACT DOCUMENTS.....	16
<b>ARTICLE 2 – DISTRICT .....</b>	<b>19</b>
2.1    INFORMATION AND SERVICES PROVIDED BY DISTRICT.....	19
2.2    ACCESS TO PROJECT SITE.....	19
2.3    DISTRICT'S RIGHT TO STOP THE WORK.....	19
2.4    DISTRICT'S RIGHT TO CARRY OUT THE WORK.....	20
<b>ARTICLE 3 – CONTRACTOR.....</b>	<b>21</b>
3.1    REVIEW OF THE SITE, CONTRACT DOCUMENTS AND FIELD CONDITIONS.....	21
3.2    SUPERVISION AND CONSTRUCTION PROCEDURES.....	23
3.3    RESPONSIBILITY FOR THE WORK .....	23
3.4    LABOR, WORKMANSHIP, MATERIALS AND MANUFACTURED ITEMS .....	24
3.5    CONTRACTOR'S WARRANTY .....	24
3.6    CONSTRUCTION METHODS AND PROCEDURES.....	24
3.7    TAXES.....	25
3.8    LEGAL REQUIREMENTS.....	25
3.9    SUPERINTENDENT/PROJECT STAFF.....	25
3.10   SCHEDULES REQUIRED OF CONTRACTOR .....	26
3.11   DOCUMENTS AND SAMPLES AT PROJECT SITE.....	28
3.12   SUBMITTALS .....	29
3.13   TRADE NAMES, SUBSTITUTIONS .....	31
3.14   DAILY REPORTS BY CONTRACTOR.....	32
3.15   CUTTING AND PATCHING .....	33
3.16   ACCESS TO THE WORK .....	33
3.17   ROYALTIES AND PATENTS.....	33
3.18   PERMITS AND LICENSES.....	34
3.19   DIFFERING SITE CONDITIONS.....	34
3.20   INSPECTIONS.....	35
3.21   INDEMNIFICATION, STOP NOTICES.....	36
3.22   PARKING .....	36

3.23	<i>USE OF THE PROJECT SITE AND CLEAN UP</i> .....	36
3.24	<i>ENVIRONMENTAL CONTROLS</i> .....	38
<b>ARTICLE 4 – ADMINISTRATION OF THE CONTRACT</b> .....		<b>44</b>
4.1	<i>CONTRACT ADMINISTRATION BY DISTRICT, DESIGN CONSULTANT AND CONSTRUCTION MANAGER</i> .....	44
4.2	<i>CLAIMS</i> .....	45
<b>ARTICLE 5 – SUBCONTRACTORS</b> .....		<b>51</b>
5.1	<i>CONTRACTOR'S AWARD OF SUBCONTRACTS</i> .....	51
5.2	<i>SUBCONTRACTUAL RELATIONS</i> .....	52
5.3	<i>CONTINGENT ASSIGNMENT OF SUBCONTRACTS</i> .....	54
<b>ARTICLE 6 – CONSTRUCTION BY DISTRICT OR BY SEPARATE CONTRACTORS</b> .....		<b>55</b>
6.1	<i>DISTRICT'S RIGHT TO PERFORM CONSTRUCTION AND TO AWARD SEPARATE CONTRACTS</i> .....	55
6.2	<i>MUTUAL RESPONSIBILITY</i> .....	55
6.3	<i>DISTRICT'S RIGHT TO CLEAN UP</i> .....	56
<b>ARTICLE 7 – CHANGES</b> .....		<b>57</b>
7.1	<i>CHANGES</i> .....	57
7.2	<i>CHANGE ORDERS AND CHANGE ORDER REQUESTS</i> .....	58
7.3	<i>FIELD ORDERS</i> .....	64
7.4	<i>DISPUTES REGARDING CHANGES</i> .....	64
<b>ARTICLE 8 – CONTRACT TIME</b> .....		<b>65</b>
8.1	<i>COMMENCEMENT OF THE WORK</i> .....	65
8.2	<i>PROGRESS AND COMPLETION</i> .....	65
8.3	<i>DELAY</i> .....	66
<b>ARTICLE 9 – PAYMENTS AND COMPLETION</b> .....		<b>69</b>
9.1	<i>SCHEDULE OF VALUES</i> .....	69
9.2	<i>PROGRESS PAYMENT</i> .....	69
9.3	<i>APPLICATION FOR PAYMENT</i> .....	70
9.4	<i>CERTIFICATE FOR PAYMENT</i> .....	71
9.5	<i>DEPOSIT OF SECURITIES IN LIEU OF RETENTION AND DEPOSIT OF RETENTION INTO ESCROW</i> .....	73
9.6	<i>BENEFICIAL OCCUPANCY/BENEFICIAL USE</i> .....	73
9.7	<i>SUBSTANTIAL COMPLETION</i> .....	75
9.8	<i>FINAL COMPLETION AND FINAL PAYMENT</i> .....	75
<b>ARTICLE 10 – PROTECTION OF PERSONS AND PROPERTY</b> .....		<b>77</b>
10.1	<i>SAFETY PRECAUTIONS AND PROGRAMS</i> .....	77
10.2	<i>SAFETY OF PERSONS AND PROPERTY</i> .....	77

(v) General Conditions

---

10.3	<i>EMERGENCIES</i>	79
<b>ARTICLE 11 – INSURANCE AND BONDS</b>		<b>80</b>
11.1	<i>CONTRACTOR'S INSURANCE</i>	80
11.2	<i>BOND REQUIREMENTS</i>	80
<b>ARTICLE 12 – DEFECTIVE WORK</b>		<b>82</b>
12.1	<i>UNCOVERING OF WORK</i>	82
12.2	<i>CORRECTION OF DEFECTIVE WORK AND GUARANTEE TO REPAIR PERIOD</i>	82
12.3	<i>ACCEPTANCE OF DEFECTIVE WORK</i>	84
<b>ARTICLE 13 – STATUTORY REQUIREMENTS</b>		<b>85</b>
13.1	<i>NONDISCRIMINATION/EQUAL OPPORTUNITY</i>	85
13.2	<i>STATE LABOR LAW</i>	87
13.3	<i>PAYROLL RECORDS</i>	88
13.4	<i>APPRENTICES</i>	89
13.5	<i>WORK DAY</i>	89



## **ARTICLE 1 – GENERAL PROVISIONS**

### **1.1 DEFINITIONS**

Terms appearing in the Contract Documents with initial capitalization shall have the meanings set forth below:

1.1.1 **ACCEPTANCE:** The point after Final Completion when Contractor has fully performed all of the requirements of the Contract Documents and the Work is accepted by District in writing.

1.1.2 **ADDENDA, ADDENDUM:** Written or graphic information (including, without limitation, Drawings or Special Provisions and Technical Specifications) prepared and issued by District General Manager or its designee prior to the receipt of Contractor's Bid, which modify or interpret the Bid Documents by additions, deletions, clarifications or corrections.

1.1.3 **ALLOWABLE COSTS:** Costs for which reimbursement is allowed under Article 7.2.5 of these General Conditions and for which reimbursement is allowed under other provisions of the Contract Documents, that may be added by Change Order to the Contract Sum for Extra Work or deducted by Change Order from the Contract Sum for Deleted Work.

1.1.4 **ALTERNATE(S):** Those portions of the Bid setting forth the price(s) for optional or alternative items of Work not covered by the Base Bid.

1.1.5 **APPLICABLE CODE REQUIREMENTS:** All applicable federal, state and municipal laws, statutes, building codes, ordinances and regulations of governmental authorities having jurisdiction over the Project, Work, Site, Contractor or District.

1.1.6 **APPLICATION FOR PAYMENT:** An itemized application for payment prepared and submitted by Contractor for review and approval by District, which is prepared, submitted and accompanied by supporting documentation in accordance with the requirements of the Contract Documents.

1.1.7 **APPROVE, APPROVED or APPROVAL:** Whether capitalized or not capitalized, shall mean, unless otherwise stated, either an express approval contained in a written statement signed by the approving individual or entity or deemed approved in accordance with the terms, conditions and procedures set forth in the Contract Documents. All such approvals by or on behalf of District (including, without limitation, approvals by Construction Manager) may be granted or withheld in the sole discretion of District.

1.1.8 **AS-BUILT DOCUMENTS:** The Contract Documents showing the condition of the Work as actually built, including, without limitation, the locations of

mechanical, electrical, plumbing, HVAC or similar portions of the Work that are shown diagrammatically in the Contract Documents approved by District. These documents are maintained by Contractor on the Site and delivered, along with an electronic version of the set, to District upon Final Completion.

1.1.9 BASE BID: The sum stated in the Bid to perform the Work, exclusive of any Alternate(s).

1.1.10 BENEFICIAL OCCUPANCY: District's right, at its option and convenience, to occupy or otherwise make use of all or any part of the Work prior to either Substantial Completion, Final Completion, or Acceptance.

1.1.11 BID: Contractor's written bid proposal submitted to District for the Project in response to District's Notice Inviting Bids.

1.1.12 BID DOCUMENTS: The following collection of documents are designated as the Bid Documents:

- (i) Notice Inviting Bids.
- (ii) Instructions to Bidders.
- (iii) Blank Bid Form.
- (iv) Construction Contract between District and Contractor.
- (v) General Conditions.
- (vi) Special Provisions and Technical Specifications.
- (vii) Plans and Drawings.
- (viii) Bidding Addenda.
- (ix) Reports, Supplements, Attachments, Modifications, and Exhibits attached to the above items.

1.1.13 CERTIFICATE FOR PAYMENT: The form for approval by the Construction Manager of Contractor's Application for Payment.

1.1.14 CHANGE: Whether capitalized or not, when used in reference to changes in the Work is a generic term encompassing additions, deletion, alterations or changes in the Work, which may or may not involve Extra Work and for which Contractor may or may not be entitled to a Change Order under the terms of the Contract Documents.

1.1.15 CHANGE ORDER: A written instrument signed by District, or by District and  
(v) General Conditions

Contractor, describing a Change to the Work of Contractor.

1.1.16 CHANGE ORDER REQUEST: Contractor's written request for an adjustment in the Contract Sum or Contract Time due to a Change resulting in Extra Work or Deleted Work.

1.1.17 DISTRICT: Oceano Community Services District, a California special district.

1.1.18 CONTRACTOR CLAIM: A separate demand by a Contractor sent by registered mail or certified mail, with return receipt requested, for one or more of the following: (A) a time extension, including, without limitation, for relief from damages or penalties for delay assessed by the District; (B) payment by the District of money or damages arising from work done by, or on behalf of, the Contractor pursuant to the Construction Contract and payment for which is not otherwise expressly provided or to which the claimant is not otherwise entitled; (C) payment of an amount that is disputed by the District. A Contractor Claim does not include, and the procedures for processing of Contractor Claims do not apply to the following:

- (i) Penalties or forfeitures prescribed by statute or regulation imposed by a governmental agency other than penalties for delay assessed by the District pursuant to Section 1.1.18(B);
- (ii) Tort claims for personal injury or death;
- (iii) False claims liability under California Government Code Section 12650, et seq.;
- (iv) Defects in the Work first discovered by District after final payment by District to Contractor;
- (v) Stop notices;
- (vi) The right of District to specific performance or injunctive relief to compel performance of any provision of the Contract Documents or for other District claims against the Contractor.

1.1.19 COMPENSABLE DELAY: A Delay for which Contractor may be entitled under the Contract Documents to both an extension of the Contract Time and an adjustment of the Contract Sum for additional compensation. "Compensable Delay" means any Delay to the path of activities that is critical to Contractor's Substantial Completion of the Work within the Contract Time, which Delay is all of the following:

- (v) General Conditions

- (i) Solely due to Changes requested by District that adds time, but does not involve Extra Work.
- (ii) Not due, in whole or in part, to the fault or negligence or breach of Contractor or any Subcontractor or Sub-subcontractor, of any Tier.
- (iii) Not concurrent with another Excusable Delay or any Unexcused Delay.

1.1.20 CONSTRUCTION CONTRACT: The written contract executed between District and Contractor for construction of the Project.

1.1.21 CONSTRUCTION MANAGER: The District General Manager or any person designated by the District General Manager or District Board to oversee the Project. The Construction Manager can be an individual, partnership, corporation, joint venture or other legal entity under contract with District to perform construction management services for the Project. The term "Construction Manager" means Construction Manager or Construction Manager's authorized representative.

1.1.22 CONSTRUCTION SCHEDULE: The graphical representation of Contractor's as-planned schedule for performance of the Work, prepared in accordance with the requirements of the Contract Documents and that provides for Substantial Completion of the Work within the Contract Time.

1.1.23 CONTRACT DISPUTE: A dispute, other than a dispute listed in Section 14.2.1 (Non-Contract Disputes) of the Construction Contract, arising out of or related to the Construction Contract or the interpretation, enforcement or breach thereof.

1.1.24 CONTRACT DISPUTE RESOLUTION PROCESS: The process of resolution of Contract Disputes, and, upon election of District, disputes as set forth in Section 14 (Dispute Resolution) of the Construction Contract.

1.1.25 CONTRACT DOCUMENTS: The following collection of documents are designated as contract documents:

- (i) The Notice Inviting Pre-Qualification Statements, Pre-Qualification Statement, and Pre-Qualification Checklist (if applicable).
- (ii) Executed Construction Contract between District and Contractor.
- (iii) Notice Inviting Bids.
- (iv) Instructions to Bidders.
- (v) General Conditions

- (v) Bidding Addenda.
- (vi) Contractor's Bid.
- (vii) General Conditions.
- (viii) Special Provisions and Technical Specifications.
- (ix) Performance and Payment Bonds.
- (x) Insurance Forms.
- (xi) Plans and Drawings.
- (xii) Reports listed in the Bidding Documents.
- (xiii) Supplements, Attachments and Exhibits attached to the above items.
- (xiv) Modifications.
- (xv) Change Orders.
- (xvi) Field Orders.
- (xvii) Other Documents if so designated by written agreement of the Parties.

1.1.26 CONTRACT SUM: The total amount of compensation stated in the Construction Contract that is payable to Contractor for the performance of the Work in accordance with the Contract Documents.

1.1.27 CONTRACT TIME: The total number of days set forth in the Construction Contract within which Substantial Completion of the Work must be achieved by Contractor, including approved extensions of time permitted under the terms of the Contract Documents.

1.1.28 CONTRACTOR: The individual or firm under contract with District to serve as the General Contractor for construction of the Project. The term "Contractor" means Contractor or Contractor's authorized representative.

1.1.29 CONTRACTOR MARKUP: The additional sum or deductive credit provided for under the Construction Contract for Contractor's profit and overhead on Extra or Deleted Work for which a Change Order is required to be executed under the Contract Documents adjusting the Contract Sum.

1.1.30 DAY: Whether capitalized or not, unless otherwise specifically provided, means calendar day. NOTE: For Federally-funded projects DAY, whether capitalized or not, is considered WORKING DAY and is defined as any day, except weekends and legal holidays.

(v) General Conditions

1.1.31 DEFECTIVE WORK: Work by Contractor that is unsatisfactory, faulty, omitted, incomplete, deficient or does not conform to the Applicable Code Requirements, the Contract Documents, the directives of District or the requirements of any inspection, reference standard, test, code or approval specified in the Contract Documents.

1.1.32 DELAY: Whether capitalized or not, includes any circumstances involving disruption, hindrance, or interference in the performance of the Work.

1.1.33 DELETED WORK: Work that is eliminated due to a Change in the Work requested by District or Contractor for which District is entitled to a deductive adjustment in the Contract Sum.

1.1.34 DESIGN CONSULTANT. The individual(s) or firm(s) under contract with District to provide design or engineering services for the Project and are responsible for preparing the Contract Documents for the Project. The term "Design Consultant" means Design Consultant or Design Consultant's authorized representative.

1.1.35 DIFFERING SITE CONDITIONS. Differing Site Conditions are those conditions encountered at the Site or in Existing Improvements that are (1) subsurface or concealed conditions which differ materially from those indicated in the Contract Documents; or (2) unknown physical conditions at the Site, of an unusual nature, differing materially from those ordinarily encountered and generally recognized as inherent in the Work of the character provided for in the Contract Documents.

1.1.36 DRAWINGS: The graphic and pictorial portions of the Contract Documents showing the design, location, and dimensions of the Work, generally including plans, elevations, subparagraphs, details, schedules and diagrams. The Drawings are outlined in the Drawing Index. The term "Drawings" may be used interchangeably with "Plans."

1.1.37 ESCROW AGENT: A state or federally chartered bank in the State of California which holds securities pursuant to an escrow agreement as set forth in Article 9.5 of these General Conditions.

1.1.38 EXCUSABLE DELAY: A Delay for which Contractor may be entitled under the Contract Documents to an extension of time, but not compensation. "Excusable Delay" means any delay to the path of activities that is critical to Substantial Completion of the Work within the Contract Time caused by conditions beyond the control or foreseeability, and without the fault or negligence of Contractor or its Subcontractors or Sub-subcontractors, of any Tier, such as, but not limited to: war, embargoes, fire, unavoidable casualties, unusual delays in transportation, national emergency, and stormy and inclement weather

conditions that are unusual and unseasonable and in which the Work cannot continue. Without limitation to the foregoing, the financial inability of Contractor or any Subcontractor or Sub-subcontractor, shall not be deemed conditions beyond Contractor's control or foreseeability. Contractor may claim an Excusable Delay only if all Work on a critically scheduled activity is stopped for more than six (6) hours of a normal eight (8) hour working day, or if three to six hours are lost in one working day, then it may be claimed for one-half day. A Compensable Delay shall, to the extent that it is concurrent with an Excusable Delay, be conclusively deemed an Excusable Delay.

**1.1.39 EXISTING IMPROVEMENTS:** All improvements located on the Site as of the date of execution of the Construction Contract, whether above or below the surface of the ground, including but not limited to existing buildings, utilities, infrastructure improvements and other facilities.

**1.1.40 EXTRA WORK:** Additional Work or costs due to a Change in the Work that is not described in or reasonably inferable from the Contract Documents and for which Contractor is entitled to an adjustment of the Contract Sum under the terms of the Contract Documents. Extra Work shall not include additional Work or costs arising from Contractor's failure to perform any of its duties or obligations under the Contract Documents or arising from errors, omissions, conflicts, ambiguities, lack of coordination or noncompliance with Applicable Code Requirements in the Contract Documents with respect to which Contractor has assumed responsibility in connection with its obligation to conduct a careful review of the Bid Documents and Contract Documents.

**1.1.41 FIELD ORDER:** A written instrument signed by the Construction Manager that requests performance of Work in one of the following categories:

- (i) Over which there is a dispute as to whether the Work is or is not Extra Work.
- (ii) Involving Extra Work which District requests be performed without a unilateral Change Order adjustment to the Contract Sum or Contract Time and before all terms of an adjustment to the Contract Sum or Contract Time are fully agreed upon by District and Contractor.

The purpose of a Field Order is to direct performance of Work, which may be disputed, and, whether or not it expressly so states, shall not be construed as an acknowledgment by District that the Work described constitutes a Change or Extra Work if that is, in fact, not the case.

**1.1.42 FINAL COMPLETION:** The point at which:

- (i) Work is completed to the satisfaction of District in accordance with the Contract Documents, including minor corrective or completion items.

(ii) All requirements of the Contract Documents entitling Contractor to final payment shall have been performed by Contractor (including, without limitation, delivery of all warranties and guarantees, equipment operation and maintenance manuals, as-built drawings and schedules and certificates required prior to occupancy).

(iii) All approvals and acceptances shall have been made pursuant to Applicable Code Requirements.

(iv) All rubbish, tools, scaffolding and surplus materials and equipment have been removed from the Site.

1.1.43 FRAGNET: A "Fragnet", sometimes referred to as "time impact analysis," is a contemporaneous, fragmentary scheduling network, which graphically identifies the sequencing of all critical and non-critical new activities and/or activity revisions affected by a Change Order Request, Field Order or Change Order, with logic ties to all affected existing activities noted on the Construction Schedule. Its objective is to isolate and quantify any time impact of a specific issue, determine and demonstrate any such specific Delay in relation to past and/or other current Delays and to provide a method for incorporating adjustments to the Contract Time into the Construction Schedule.

1.1.44 GENERAL CONDITIONS: That portion of the Contract Documents relating to the administrative procedures to be followed by Contractor in carrying out the Work.

1.1.45 HAZARDOUS SUBSTANCES: Refers to, without limitation, the following: any chemical, material or other substance defined as or included within the definition of hazardous substances, hazardous wastes, extremely hazardous substances, toxic substances, toxic material, restricted hazardous waste, special waste, or words of similar import under any Environmental Law.

1.1.46 LOSSES: Any and all losses, costs, liabilities, Claims, damages, liquidated damages, actions, judgments, settlements, expenses, fines and penalties. "Losses" do not include attorneys' fees.

1.1.47 MODIFICATION: A document other than a Change Order, approved by District Legal Counsel and signed by District or Construction Manager and Contractor, agreeing to alter, amend or modify the Contract Documents.

1.1.48 NON-COMPENSABLE DELAY: An (i) Unexcused Delay; and (ii) an Excusable Delay that is not also a Compensable Delay.

1.1.49 NOTICE OF AWARD: Written notice issued by District notifying Contractor of issuance of the Construction Contract.

1.1.50 NOTICE TO PROCEED: Written notice issued by District to Contractor to

(v) General Conditions



begin the Work.

1.1.51 PERFORMANCE BOND, PAYMENT BOND: The performance and payment bonds to be provided by Contractor for the Project.

1.1.52 PLANS: The graphic and pictorial portions of the Contract Documents showing the design, location and dimensions of the Work, generally including plans, elevations, subparagraphs, details, schedules and diagrams. The term "Plans" may be used interchangeably with "Drawings."

1.1.53 PRE-CONSTRUCTION MEETING: A meeting held with the Project Team prior to beginning construction in order to review Contract Documents and clarify roles, responsibilities and authority of the Project Team.

1.1.54 PROJECT: The total construction, of which the Work performed by Contractor under the Contract Documents may be the whole or part and which may include Work performed by District's own forces or by Separate Contractors.

1.1.55 PROJECT TEAM: Collectively, the Contractor, District, Design Consultant, Separate Contractors, Construction Manager and other consultants and contractors providing professional and technical consultation for the design and construction of the Project.

1.1.56 RECORD DOCUMENTS: The term "Record Documents" refers to the As-Built Documents, warranties, guarantees and other documents required to be submitted by Contractor as a condition of Final Completion.

1.1.57 REQUEST FOR INFORMATION: A written instrument, prepared by Contractor, which requests an interpretation or clarification in the Work or a response to a question concerning the Work. A Request for Information does not entitle Contractor to an adjustment in the Contract Sum unless it requires Extra Work and Contractor requests and is entitled to such an adjustment in accordance with the provisions of the Contract Documents.

1.1.58 REQUEST FOR INFORMATION RESPONSE: A written instrument, usually prepared by the Design Consultant, which sets forth an interpretation or clarification in the Work or a response to a Contractor question concerning the Work.

1.1.59 SCHEDULE OF VALUES: A detailed, itemized breakdown of the Contract Sum, which provides for a fair and reasonable allocation of the dollar values to each of the various parts of the Work.

1.1.60 SEPARATE CONTRACTOR: A person or firm under separate contract with District or other entity performing other Work at the Site.

1.1.61 SITE: The physical site located within District where the Project is to be

constructed, including all adjacent areas for staging, storage, parking and temporary offices.

**1.1.62 SPECIAL PROVISIONS AND TECHNICAL SPECIFICATIONS:** The portion of the Contract Documents consisting of the written requirements for materials, equipment, standards, skill, quality for the Work and performance of related services. These provisions may also contain amendments, deletions or additions to the General Conditions.

**1.1.63 STATEMENT OF CONTRACT DISPUTE:** The Contractor's written statement prepared in accordance with Section 14.3 (Submission of Contractor Claim) of the Construction Contract required as a condition of its initiating the Contract Dispute Resolution Process.

**1.1.64 SUBCONTRACTOR:** A person or firm that has a contract with a Contractor to perform a portion of the Work. The term "Subcontractor" includes suppliers and vendors and is referred to throughout the Contract Documents as if singular in number and means a Subcontractor or an authorized representative of the Subcontractor.

**1.1.65 SUB-SUBCONTRACTOR:** A person or firm that has a contract with a Subcontractor to perform a portion of the Work. The term "Sub-subcontractor" includes suppliers and vendors and is referred to throughout the Contract Documents as if singular in number and means a Sub-subcontractor or an authorized representative of the Sub-subcontractor.

**1.1.66 SUBCONTRACTOR/SUB-SUBCONTRACTOR MARKUPS:** The sum allowable under the Construction Contract for Subcontractor and Sub-subcontractor profit and overhead on Extra or Deleted Work for which Contractor is entitled to a Change Order under the Contract Documents adjusting the Contract Sum.

**1.1.67 SUBMITTALS:** All shop drawings, samples, exemplars, product data and other submittals required to be submitted by Contractor under the Contract Documents.

**1.1.68 SUBSTANTIAL COMPLETION, SUBSTANTIALLY COMPLETE:** The point at which the Work is sufficiently complete to be occupied and/or utilized by District for its intended purpose, and Contractor has fulfilled its obligations under the Contract Documents as determined by District, except for minor punch-list items which do not impair District's ability to so occupy and utilize the Project.

**1.1.69 SUPERINTENDENT:** The person appointed by Contractor, subject to approval by District, to supervise and coordinate Contractor's own forces and Subcontractors in all aspects of the Work.

1.1.70 TIER: The contractual level of a Subcontractor with respect to Contractor. For example, a first-tier Subcontractor is under subcontract with Contractor. A Sub-subcontractor under subcontract with a first-tier Subcontractor, is in the second tier, and so on.

1.1.71 UNEXCUSED DELAY: Any Delay in the path of activities that is critical to Substantial Completion of the Work within the Contract Time resulting from causes other than Excusable Delay or Compensable Delay. An Unexcused Delay shall not entitle Contractor to either an extension of the Contract Time or an adjustment of the Contract Sum. A Compensable Delay or Excusable Delay shall, to the extent it is concurrent with an Unexcused Delay, be conclusively deemed an Unexcused Delay.

1.1.72 WORK: All labor, materials, equipment, services, permits, licenses and taxes, and all other things necessary for Contractor to perform its obligations and complete the Project, including, without limitation, any changes or additions requested by District, in accordance with the Contract Documents and all Applicable Code Requirements.

1.1.73 INTERPRETATION OF “SHALL” AND “MAY.” Where applicable to determine obligations of the Parties, the term “SHALL” is to be construed as mandatory and “MAY” shall be construed as permissive.

## **1.2 OWNERSHIP AND USE OF DOCUMENTS**

1.2.1 All originals, copies and electronic forms of Drawings, Plans, specifications, shop drawings, samples, reports, schedules and other materials or documents prepared for the Project (including, without limitation, the Contract Documents) shall not be used by Contractor, or any Subcontractor or Sub-subcontractor, of any Tier, for any purpose other than performance of the Work. Contractor, Subcontractors and Sub-subcontractors are granted a limited license, revocable at will by District, to use and reproduce applicable portions of the Contract Documents appropriate to and for use in the execution of their Work under the Contract Documents; provided however, that such use shall not be construed in derogation of Owner’s rights to use and ownership under this provision.

1.2.2 Contractor shall keep on the Site of the Project, at all times, a complete set of District approved, permitted Contract Documents for use by District.

1.2.3 Proposed Changes or refinements and clarifications will be provided to Contractor in the form of reproducible prints. Contractor shall, at its own expense and without adjustment to the Contract Sum, do all reproduction and distribution of such reproducible prints as necessary for the complete pricing of the Change and for performance of the Work.

1.2.4 Contractor shall take all necessary steps to assure that a provision is included in all contracts with Subcontractors and Sub-subcontractors, of every

Tier, who perform Work on the Project, protecting and preserving District's rights to ownership and use of documents as set forth in this Article 1.2.

1.2.5 All documents, including but not limited to Drawings, Plans, specifications, shop drawings, samples, reports, schedules and other materials or documents prepared for the Project (including, without limitation, the Contract Documents) shall be owned exclusively by the District prior to and after completion of the Project.

### **1.3 AUTHORITY OF DISTRICT**

1.3.1 The Design Consultant shall, upon request, make recommendations to District and the Construction Manager concerning the quality or acceptability of Work performed.

1.3.2 District, in its sole discretion, will interpret the Contract Documents and make the determination of whether or not Contractor has fulfilled the requirements of the Contract Documents. Such interpretations and decisions of District shall be final and binding upon Contractor.

### **1.4 INTERPRETATION OF CONTRACT DOCUMENTS**

1.4.1 The Contract Documents are complementary and what is required by one shall be as binding as if required by all.

1.4.2 In general, the Drawings will show dimensions, positions, and kind of construction; and the Special Provisions and Technical Specifications will define materials, quality and standards. Any Work called for on the Drawings and not mentioned in the Special Provisions and Technical Specifications, or vice versa, shall be performed as though fully set forth in both. Work not particularly detailed, marked or specified, shall be the same as similar parts that are detailed, marked or specified.

1.4.3 Unless otherwise stated in the Contract Documents, technical words and abbreviations contained in the Contract Documents are used in accordance with commonly understood construction industry meanings and non-technical words and abbreviations are used in accordance with their commonly understood meanings.

1.4.4 The Contract Documents may omit modifying words such as "all" and "any," and articles such as "the" and "an." If a modifier or an article is not included in one statement and appears in another it is not intended to affect the interpretation of either statement. The use of the word "including," when following any general statement, shall not be construed to limit such statement to specific items or matters set forth immediately following such word or to similar items or matters whether or not non-limiting language (such as "without limitation," "but not limited to," or words of similar import) is used with reference

thereto, but rather shall be deemed to refer to all other items or matters that could reasonably fall within the broadest possible scope of such general statement. To the extent the Contract Documents define obligations of the parties, the word "shall" means a mandatory obligation and "may" means a permissive obligation.

1.4.5 Whenever the context so requires, the use of the singular number shall be deemed to include the plural and vice versa. Each gender shall be deemed to include the other gender, and each shall include corporation, partnership, trust, or other legal entity whenever the context so requires. The captions and headings of the various subdivisions of the Contract Documents are intended only as a matter of reference and convenience and in no way define, limit, or prescribe the scope or intent of the Contract Documents or any subdivision thereof.

1.4.6 Any cross-references indicated between various subparagraphs or Drawings and Documents are provided for the convenience of Contractor and shall not be deemed to be all-inclusive.

1.4.7 Unless specifically noted to the contrary, it is the intention of the Contract Documents that all Work, equipment, casework, mechanical, electrical and similar devices of whatever nature, be completely installed, hooked-up, made operational and made functional for the purpose such are intended, and that all costs therefor be included in the Contract Sum.

1.4.8 Figured dimensions on scale Drawings and on full size Drawings shall govern over scale Drawings without figured dimensions. The Drawings shall not be scaled to determine dimensions, and (except in the case of diagrammatic Drawings) shall be calculated from figures shown on the Drawings. Obvious discrepancies between scale and figured dimensions, not marked "not to scale," must be brought to the Construction Manager's attention before proceeding with the Work affected by the discrepancy.

1.4.9 If there is a conflict between or among any of the Contract Documents, Contractor shall immediately bring such conflict to the attention of District, whose decisions regarding such conflict shall be final and binding as to the requirements of the Contract Documents. In the event of any conflicts between or among the Applicable Code Requirements, the more stringent shall govern. In resolving any conflict in the Contract Documents, the highest standard of quality and skill, the most stringent requirements, and the most specific provision of the Contract Documents shall govern and shall be required in the performance of the Work.

1.4.10 The general character of the Work is shown in the Contract Documents, but Changes, Modifications, clarifications and refinements may be made in details when needed to more fully explain the Work. Provided that there is a logical evolution of the Bid Documents that were bid by Contractor or were reasonably inferable as necessary to provide a completed and fully operational system,

facility or structure, the same shall be considered part of the scope of the Work to be performed without adjustment in the Contract Sum or the Contract Time.

1.4.11 Where on any Drawing a portion of the Work is drawn out and the remainder is indicated in outline, the drawn-out parts shall apply also to all other like portions of the Work. Where ornament or other detail is indicated on starting only, such detail shall be continued throughout the course of parts in which it occurs and shall also apply to all other similar parts in the Work unless otherwise indicated.

1.4.12 For convenience, the Special Provisions and Technical Specifications are arranged in various trade subparagraphs, but such segregation shall not be considered as limiting the Work of any subcontract or trade. Contractor shall be solely responsible for all subcontract arrangements of Work regardless of the location or provision in the Special Provisions and Technical Specifications.

1.4.13 Contractor will provide all necessary labor, equipment, transportation and incidentals required to complete the Work, even if the Contract Documents do not describe the Work in complete detail.

1.4.14 Drawings and diagrams for mechanical, plumbing and electrical Work shall be considered as diagrammatic only, not to be used for any structural guidance or physical layout, unless specifically detailed or dimensioned, and Contractor shall be responsible to provide any and all numbers and lengths of mechanical, plumbing or electrical fittings, wire, conduit, connections, attachments or similar materials needed to complete the Work, at no adjustment to the Contract Sum or Contract Time, whether or not they exceed the numbers of such pieces or the lengths indicated by the Drawings.

---

## **ARTICLE 2 – DISTRICT**

### **2.1 INFORMATION AND SERVICES PROVIDED BY DISTRICT**

2.1.1 District will furnish up to five (5) (sets) of the Contract Documents or portions thereof free of charge.

2.1.2 Except as otherwise provided in the Special Provisions and Technical Specifications and Article 3.18 herein, District shall obtain and pay for any permits, easements and governmental approvals for the use or occupancy of permanent structures required in connection with the Work.

2.1.3 Requests for Information Responses, Approvals and decisions required of District, Design Consultant or Construction Manager under the Contract Documents shall be provided by District, Design Consultant or Construction Manager to Contractor upon request in a timely manner in order to avoid unreasonable Delay in the orderly and sequential progress of the Work. Notwithstanding the foregoing, failure by District, Design Consultant, Construction Manager or District's other consultants to provide Request for Information Response, Approvals or decisions shall not be considered as a basis for Contractor to seek adjustment in the Contract Time until seven (7) Days after Contractor has delivered written notice to District and to the person from whom such information, Approval or decision is needed, stating the following:

- (i) You are hereby notified that certain information, approval or decision described herein has not been provided in accordance with this provision and if not provided within seven (7) Days from this notice may result in additional cost or a request for time extension due to Delay;
- (ii) A detailed description of the information, approval or decision required; and
- (iii) The date by which the information, approval or decision must be received as to not result in Delay to the Project, which shall in no event be earlier than seven (7) Days after the date of District's receipt of such notice.

### **2.2 ACCESS TO PROJECT SITE**

2.2.1 District will make available, no later than the date designated in the current Construction Schedule accepted by District, the lands and facilities upon which the Work is to be performed, including such access and other lands and facilities designated in the Contract Documents, for use by Contractor.

### **2.3 DISTRICT'S RIGHT TO STOP THE WORK**

2.3.1 If Contractor fails to correct Defective Work as required by Article 12.2, fails to perform the Work in accordance with the Contract Documents, or violates

(v) General Conditions

any Applicable Code Requirement, District may direct Contractor to stop the Work, or any portion thereof, until the cause for such order has been eliminated by Contractor. Contractor shall not be entitled to any adjustment of Contract Time or Contract Sum as a result of any such order. District shall have no duty or responsibility to Contractor or any other party to exercise the right to stop the Work.

## **2.4 DISTRICT'S RIGHT TO CARRY OUT THE WORK**

2.4.1 If Contractor fails to carry out the Work in accordance with the Contract Documents, fails to provide sufficient labor, materials, equipment, tools and services to maintain the Construction Schedule, or otherwise fails to comply with any requirement of the Contract Documents, and fails within the time specified in the Contract Documents, after receipt of notice from District to promptly commence and thereafter diligently continue to completion the correction of such failure, District may, without prejudice to other remedies District may have, correct such failure at Contractor's expense. In such case, District shall be entitled to deduct from payments then or thereafter due Contractor the cost of correcting such failure, including compensation for the additional services and expenses of District and District's consultants made necessary thereby. If payments then or thereafter due Contractor are not sufficient to cover such amounts, Contractor shall pay the additional amount to District.

---



## **ARTICLE 3 – CONTRACTOR**

### **3.1 REVIEW OF THE SITE, CONTRACT DOCUMENTS AND FIELD CONDITIONS**

3.1.1 Contractor acknowledges that it is satisfied as to character, quality, and quantities of surface and subsurface materials or obstacles to be encountered insofar as reasonably ascertainable from a careful inspection of the Site (including, without limitation, Existing Improvements on the Site) and from the geological investigation reports, data and similar information made available to Contractor by District. Any failure by Contractor to take such information or conditions into consideration will not relieve Contractor from responsibility for estimating the difficulty and cost of successfully completing the Work within the Contract Sum and Contract Time.

3.1.2 Contractor warrants and represents that it has carefully reviewed and compared the Bid and Bid Documents prior to submitting its Bid and executing the Contract. Based upon its careful review, Contractor agrees that it shall not be entitled, and conclusively waives any right, to an adjustment in the Contract Sum or Contract Time for any additional or unforeseen costs or Delay in the performance of Work due to conditions in Contract Documents constituting errors, omissions, conflicts, ambiguities, lack of coordination or noncompliance with Applicable Code Requirements, if such conditions were either discovered by Contractor or could have been reasonably discovered by Contractor or its Subcontractors or Sub-subcontractors, of every Tier, in the exercise of care and diligence in the review of the Bid Documents.

3.1.3 If Contractor discovers what it perceives to be errors, omissions, conflicts, ambiguities, lack of coordination or noncompliance with Applicable Code Requirements in the Contract Documents, then Contractor shall, before proceeding with the Work affected, notify District or the Construction Manager in writing within two (2) Days stating both of the following:

- (i) A detailed description of the conditions discovered; and
- (ii) Contractor's request for clarification, further details or correction of the Contract Documents.

Failure by Contractor to provide written notice within the period of time required shall result in Contractor waiving any right to adjustment in the Contract Sum or Contract Time on account thereof.

3.1.4 Contractor shall submit written notice thereof to District if, in Contractor's opinion, District, Design Consultant or Construction Manager furnishes additional written or verbal instructions, information or directions that Contractor considers constitute additional Work or Delay for which Contractor believes it is entitled to an adjustment of the Contract Sum or Contract Time. Such notice shall be provided

(v) General Conditions

prior to performance of the Work affected by such instruction, information or direction and seven (7) Days after Contractor first received such instruction, information or direction. Failure to provide such written notice in the manner required by this provision shall constitute a waiver by Contractor of the right to any adjustment to the Contract Sum or Contract Time by reason of such instruction, information or direction.

3.1.5 Field measurements shall be taken and existing field conditions verified by Contractor, and carefully compared with the Contract Documents and other information known to Contractor before commencing the Work. Contractor shall promptly report in writing to the Construction Manager any errors, inconsistencies, or omissions discovered.

3.1.6 If Contractor or any Subcontractor or Sub-subcontractor, of every Tier, performs any portion of the Work which it knows, or in the exercise of care and diligence should have known, involves an error, omission, conflict, ambiguity, lack of coordination or noncompliance with Applicable Code Requirements, without notifying and obtaining the written Approval of District or before obtaining a written clarification, interpretation, instruction or decision from District, Design Consultant or Construction Manager, then any Work that is performed that is not in conformance with the clarifications, interpretation, instruction or decision of District, Design Consultant or Construction Manager shall be removed or replaced and Contractor shall be responsible for the resultant Losses with no adjustment in the Contract Sum or Contract Time.

3.1.7 District does not impliedly or expressly warrant, and assumes no responsibility for, the accuracy, suitability or completeness of the Bid Documents, Contract Documents or of the data, opinions or recommendations contained or expressed in any information, data or reports provided to Contractor relating to the following conditions at the Site: geological, soils, hydrologic, groundwater, Hazardous Substances, surface and subsurface obstructions, surface and subsurface utilities or Existing Improvements. Existing Improvements at the Site, for which no specific description is made on the Drawings, but which could be reasonably assumed to interfere with the satisfactory completion of the Work, shall be removed and disposed of by Contractor, but only upon the specific direction and control of District. Without limitation to the foregoing, and notwithstanding any information provided by District pertaining to groundwater elevations and/or geological and soils conditions encountered, it is understood that it is Contractor's responsibility to determine and allow for the elevation of groundwater, and the geological and soils conditions at the date of performance of the Work and any difference between elevation of groundwater and the geotechnical and soils conditions shown in the information provided by District and groundwater and the geotechnical and soils conditions actually encountered will not be considered as a Differing Site Condition or as a basis for an adjustment to the Contract Sum or Contract Time.

## **3.2 SUPERVISION AND CONSTRUCTION PROCEDURES**

(v) General Conditions

3.2.1 Contractor shall supervise, coordinate and direct the Work using Contractor's best skill and attention and shall provide supervision sufficient to assure proper coordination and timely completion. Contractor shall be solely responsible for and have control over construction means, methods, techniques, safety, sequences, procedures and the coordination of all portions of the Work.

3.2.2 Contractor shall be responsible for the accurate layout of all portions of the Work and shall verify all dimensions on the Drawings and shall report to District any discrepancies before proceeding with related Work.

3.2.3 Contractor may be assigned working space adjacent to the Site, and all field offices, materials and equipment shall be kept within this area. Contractor shall be responsible for leaving the space in as good condition as Contractor found it, or restoring it to the condition it was in prior to Contractor commencing the Work.

3.2.4 Contractor shall be responsible to District for acts and omissions of Contractor's agents, employees, and of Contractor's Subcontractors and Sub-subcontractors, of every Tier, and their respective agents and employees. Unless otherwise stated in the Contract Documents, references to Contractor, when used in reference to an obligation bearing upon performance of the Work, shall be deemed to include Contractor's Subcontractors and Sub-subcontractors of every Tier.

3.2.5 Contractor shall not be relieved of its obligation to perform the Work in accordance with the Contract Documents by the act(s) or omission(s) by District in the administration of the Contract, or by tests, inspections or Approvals required or performed by persons or firms other than Contractor.

### **3.3 RESPONSIBILITY FOR THE WORK**

3.3.1 Contractor shall be in charge of and responsible for all portions of the Work of the Contract, and shall be responsible for conforming such portions to the requirements of the Contract Documents and readying such portions to receive subsequent Work.

3.3.2 Contractor shall at all times maintain good discipline and order among its employees and Subcontractors. Contractor shall provide competent, fully qualified personnel to perform the Work, and shall ensure that each Subcontractor and Sub-subcontractor engaged on the Site arranges the storage of materials and equipment and performance of its Work so as to interfere as little as possible with Separate Contractors or other persons engaged in work for District on the Site.

3.3.3 During the installation of Work, Contractor shall insure that existing facilities, fences, and other structures are all adequately protected. Upon Final

Completion of all Work, all facilities that may have been damaged shall be restored to a condition acceptable to District.

3.3.4 Contractor is responsible for the security of the Site and all Work provided under the terms of this Contract, as well as all Work provided by Separate Contractors that occurs on the Site at any time prior to Final Completion and Acceptance of the Work by District.

### **3.4 LABOR, WORKMANSHIP, MATERIALS AND MANUFACTURED ITEMS**

3.4.1 Contractor shall provide and pay for all labor, materials, equipment, tools, construction equipment and machinery, water, heat, utilities, transportation and other facilities and services necessary for proper execution and completion of the Work, whether temporary or permanent and whether or not incorporated or to be incorporated in the Work. Unless otherwise provided in the Contract Documents or otherwise Approved by the Construction Manager, all articles, equipment and materials incorporated in the Work shall be new, of good quality, undamaged and not defective.

### **3.5 CONTRACTOR'S WARRANTY**

3.5.1 Contractor warrants to District that all materials and equipment used in or incorporated into the Work will be of good quality, new and free of liens, Claims and security interests of third parties; that all labor, installation, materials and equipment used or incorporated into the Work will be of good quality and free from defects; and that the Work will conform with the requirements of the Contract Documents and Applicable Code Requirements. If required by District, Contractor shall furnish satisfactory evidence as to the kind and quality of materials and equipment. Manufactured items installed in the Work and not specifically covered in the Contract Documents are to be installed in strict accordance with manufacturers' current printed instructions.

3.5.2 All materials to be incorporated in the Work shall be protected from damage during delivery, storage, and handling, and after installation until Acceptance of the Work, and Contractor shall, without charge to District, be responsible for all damage due to Contractor's failure to provide such proper protection.

### **3.6 CONSTRUCTION METHODS AND PROCEDURES**

3.6.1 The methods and procedures adopted by Contractor shall be such as to secure a quality of Work satisfactory to District and to enable completion of the Work in the time agreed upon. If at any time such methods and procedures appear inadequate, District may order Contractor to improve their character or increase efficiency, and Contractor shall conform to such order; but the failure of District to order such improvement of methods or increase of efficiency will not relieve Contractor from its obligation to perform the Work in accordance with the

Contract Documents or within the Contract Time.

3.6.2 If the Contract Documents give specific instructions concerning construction means, methods, techniques, sequences or procedures, Contractor shall be fully and solely responsible for the Site safety for implementing such means, methods, techniques, sequences or procedures. If Contractor determines that such means, methods, techniques, sequences or procedures may not be safe, Contractor shall give written notice to District and shall not proceed with that portion of the Work without further written instruction by District.

### **3.7 TAXES**

3.7.1 Contractor, Subcontractors and Sub-subcontractors are responsible for paying all sales, consumer, business license, use, income and payroll, and similar taxes for the Work or portions thereof provided by Contractor and Subcontractors.

### **3.8 LEGAL REQUIREMENTS**

3.8.1 Contractor shall perform the Work in accordance with all Applicable Code Requirements, even though such requirements are not specifically mentioned in the Contract Documents.

3.8.2 When the Work required by the Contract Documents is in conflict with any Applicable Code Requirement, Contractor shall notify District and shall not proceed with the Work until District has so ordered.

### **3.9 SUPERINTENDENT/PROJECT STAFF**

3.9.1 Contractor shall employ a complete and competent project staff for the duration of the Work, which shall include separate individuals designated to act as Superintendent(s), project manager(s), project engineer(s) and administrative assistant(s), plus such other members as necessary to diligently prosecute the Work. Contractor shall not replace the designated Superintendent or project manager without a minimum seven (7) Day written notice and only with the written approval of District, which may be granted or withheld in its sole discretion. Any Project staff member and any replacement member shall be subject to the approval of District, which may be granted or withheld in its sole discretion. Upon notice from District requesting replacement of any Project staff member who is unsatisfactory to District, Contractor shall in a timely manner, but in no event longer than three (3) Days after notification, replace such member with a competent member satisfactory to District. Failure by Contractor to comply with this provision shall entitle District, at its option exercised in its sole discretion, to terminate the Contract or suspend the Work until compliance is demonstrated. All costs or damages associated with such termination or suspension shall be borne by Contractor, without adjustment in the Contract Sum or Contract Time.

3.9.2 The Superintendent shall be at the Site at all times during the performance of the Work. The Superintendent shall represent Contractor and communications given to and acknowledged by the Superintendent shall be binding on Contractor. Further, communications issued by or received from the Superintendent shall be deemed as binding on Contractor. The Superintendent must be able to read, write and communicate fluently in English. The Superintendent shall not perform the Work of any trade, pickup materials or perform any Work not directly related to the supervision and coordination of the Work.

### **3.10 SCHEDULES REQUIRED OF CONTRACTOR**

3.10.1 Contractor shall submit a preliminary Construction Schedule to District in a form approved by the Construction Manager at the Pre-Construction Meeting.

3.10.2 Updated Construction Schedules shall be submitted in the form and frequency approved by the Construction Manager.

3.10.3 The Construction Schedule and Construction Schedule updates shall meet the following requirements:

.1 Schedules must be suitable in format and clarity for monitoring progress of the Work and shall utilize the critical path method of scheduling.

.2 Schedules must provide necessary data about the timing for District's decisions and District-furnished items.

.3 Schedules must be in sufficient detail to demonstrate adequate planning and staffing for the Work.

.4 Schedules must represent a practical plan to complete the Work within the Contract Time. If at any time during the Work, any activity is not completed by its latest scheduled completion date, Contractor shall notify the Construction Manager within seven (7) Days of Contractor's plans to reorganize the work force to return to the schedule and prevent Delays on any other activity.

.5 An updated Construction Schedule shall be submitted with each progress payment request, but no less frequently than monthly, and shall include all of the following:

(i) A written narrative report detailing the actual progress of the Work as of the date of submission;

(ii) The expected progress of the Work as of such date according to the approved Construction Schedule;

(v) General Conditions

(iii) The reasons for any variance between the approved Construction Schedule and the updated Construction Schedule; and

(iv) Contractor's plan for placing the Work back on Schedule, at Contractor's expense.

3.10.4 Contractor shall plan, develop, supervise, control and coordinate the performance of the Work so the progress, sequence and timing of the Work conform to the current accepted Construction Schedule. Contractor shall continuously obtain from Subcontractors information and data about the planning for and progress of the Work, the ordering and fabrication of materials, required Submittals, and the delivery of equipment, shall coordinate and integrate such information and data in updated Construction Schedules and Record Documents, and shall monitor the progress of the Work and the delivery of equipment. Contractor shall act as the expeditor of potential and actual delays, interruptions, hindrances or disruptions for its own forces and those forces of Subcontractors, regardless of Tier. Contractor shall cooperate with District in the development of the Construction Schedule and updated Construction Schedules.

3.10.5 District's review, comments, requests for revisions, or acceptance of any schedule or scheduling data shall not:

(i) Relieve Contractor from its sole responsibility for the feasibility of the schedule and to plan for, perform, and complete the Work within the Contract Time;

(ii) Transfer responsibility for any schedule from Contractor to District; nor

(iii) Imply District's agreement with any assumption upon which such schedule is based or any matter underlying or contained in such schedule.

3.10.6 Failure of District to discover errors or omissions in schedules that it has reviewed, or to inform Contractor that Contractor, Subcontractors, or others are behind schedule, or to direct or enforce procedures for complying with the Construction Schedule, shall not relieve Contractor from its sole responsibility to perform and complete the Work within the Contract Time and shall not be a cause for an adjustment of the Contract Time or the Contract Sum.

3.10.7 Contractor shall cooperate with and coordinate its schedule with work of District and District's Separate Contractors.

### **3.11 DOCUMENTS AND SAMPLES AT PROJECT SITE**

(v) General Conditions

3.11.1 Contractor shall maintain one (1) set of As-Built Documents at the Site, which shall be kept up to date on a daily basis at all times during the performance of the Work. All performed changes, deletions or additions in the Work from that shown in the Contract Documents shall be recorded accurately and completely in the Record Documents. Upon Final Completion and as a condition to final payment, each sheet of the As-Built Documents and other Record Documents shall be signed and attested to by a representative of Contractor as being complete and accurate.

3.11.2 Contractor shall, at all times during performance of the Work, also maintain the following at the Site:

- (i) The latest updated Construction Schedule approved by District;
- (ii) Shop Drawings, product data, and samples; and
- (iii) All other required Submittals.

At all times during the course of the Project, these documents shall be available to District, the Construction Manager and the Design Consultant to audit, excerpt, or copy as they see fit. Upon Final Completion or termination of the Construction Contract, these shall be delivered to District.

3.11.3 It shall be the responsibility of Contractor to maintain a current and complete record of all Changes performed during the progress of the Project construction. The record shall be in the form of a complete set of prints of the As-Built Documents on which daily recordings are made by Contractor, indicating in detail and dimension each variation from the original set of Contract Documents and including all of the construction Work. At the completion of construction, Contractor shall, as a requirement of the Final Completion of the Work, certify that to the best of its knowledge, the As-Built Documents are true and accurate, and that the indications thereon represent all Changes performed during the construction of the Project. At the Final Completion of the Work, the As-Built and other Record Documents shall become the property of District.

3.11.4 Contractor, in concert with the Design Consultant and the Construction Manager, shall review Contractor's As-Built Documents for conformance with all current Changes prior to presenting its monthly Application For Payment. The monthly progress payment statement will not be accepted or processed by District unless the As-Built Documents are current and complete, and Approved by District.

3.11.5 At the Final Completion of the Work, all information annotated monthly on the As-Built Documents shall be fully incorporated by Contractor onto a set of mylar reproducibles furnished by Contractor. These As-Built Documents will become the permanent property of District at the Final Completion of the Work. If the As-Built Documents are prepared on a computer, then the revised computer



files shall also be provided to District in the file format specified by District.

### **3.12 SUBMITTALS**

3.12.1 Submittals are not Contract Documents. Their purpose is to demonstrate, for those portions of the Work for which Submittals are required, how Contractor proposes to conform to the information given and the design concept expressed in the Contract Documents. Prior to starting Work, Contractor shall provide to District an initial schedule for all materials and equipment for which shop drawings are required by the Contract Documents. For each required shop drawing, Contractor shall provide to District the date for the drawing's intended Submittal to the Design Consultant for review. The date required for its return to avoid Delay in any activity beyond the scheduled start date shall also be given.

3.12.2 All shop drawings and other Submittals shall be provided at Contractor's expense, when required by the Contract Documents or requested by the Construction Manager.

3.12.3 Contractor shall review, stamp approved, and submit to the Construction Manager, all Submittals required by the Contract Documents to be submitted and reviewed by the Design Consultant. Submittals to the Construction Manager without evidence thereon of Contractor's approval shall be returned, without further consideration, for resubmission in accordance with these requirements. Submittals shall be provided within the time frame specified in the Special Provisions and Technical Specifications in accordance with the Construction Schedule, and in such sequence as to cause no Delay in the Work or in the activities of District or of Separate Contractors. Submittals made by Contractor which are not required by the Contract Documents, may be returned without action by the Construction Manager or Design Consultant. Submittal to the Construction Manager and Design Consultant must include a statement, in writing, identifying any deviations from the Contract Documents required due to manufacturing or installation limitations contained in the Submittal.

3.12.4 All Submittals shall be submitted in six (6) sets, accompanied by letters of transmittal, and addressed to the Construction Manager for review. Unless otherwise specified in the Contract Documents, Submittals consisting of Drawings or Plans shall be in the form of six (6) copies. The Submittal must be in accordance with the Contract Documents. If the Submittal involves a request for substitution of materials, the request shall be clearly identified on the Submittal that it is a "Request for Substitution." Unless so clearly marked, Submittals shall not be considered as a request for substitution. If changes or corrections are required, three marked-up prints shall be returned to Contractor. Submittals shall consist of the appropriate combination of catalog sheets, material lists, manufacturer's brochures, technical bulletins, specifications, diagrams, or product samples, necessary to describe a system, product, or item. The letter of transmittal shall give a list of the numbers of the sheets submitted. All sheets shall be marked with the name of the Project and the name of

Contractor, shall be numbered consecutively, and shall be referenced to the sheets or paragraphs of the Contract Documents, referenced by sheet or subparagraph affected. Submittals shall be combined for singular assemblies, items or materials.

3.12.5 No Work requiring a Submittal shall be performed by Contractor until the Submittal has been reviewed by District, Construction Manager or Design Consultant and the Design Consultant has documented the exceptions noted on the Submittal. Contractor shall allow twenty (20) Days for review of Submittals. Once the Submittal is returned to Contractor by the Construction Manager with a statement that it has been reviewed and no exceptions are taken or further action requested, such Work shall be performed in accordance with the Submittal and the Contract Documents.

3.12.6 Contractor's Submittals represent that Contractor has determined or verified materials and field measurements and conditions related thereto and that it has checked and coordinated the information contained within such Submittals with the requirements of the Contract Documents and Submittals for related Work.

3.12.7 If Contractor discovers any conflicts, omissions or errors in Submittals, Contractor shall notify the Construction Manager and receive instruction before proceeding with the affected Work.

3.12.8 Contractor shall remain solely responsible, notwithstanding District, Construction Manager or Design Consultant's review or approval of Submittals, for deviations (including, without limitation, those arising from standard shop practice) from requirements of the Contract Documents, unless Contractor has specifically informed District, Construction Manager or Design Consultant in writing of such deviation at the time of transmitting the Submittal and District, Construction Manager or Design Consultant has given written approval of such deviation. No adjustment in the Contract Sum or Contract Time shall be permitted with respect to any such deviations that are noted in writing by Contractor and as to which District, Construction Manager or Design Consultant takes no exception or approves.

3.12.9 After review of Contractor's Submittals by District, Construction Manager or Design Consultant, the Construction Manager will transmit to Contractor the required number of sets. If the Submittals are found to be incomplete or incorrect, Contractor shall resubmit after corrective action has been taken. Contractor shall reimburse District, or District may withhold from payments due Contractor, sums owing by District for any fees charged by District, Construction Manager or Design Consultant or District's other consultants for more than two (2) reviews of a Submittal, or for accelerated review in a shorter time than set forth in the approved Construction Schedule, if requested by Contractor or caused by late Submittals by Contractor. The return of a Submittal due to failure to comply with the Contract Documents or for correction or additional information shall be considered a review.

3.12.10 Review of Submittals by District, Construction Manager or Design Consultant will be general and for conformance with design intent, and shall not relieve Contractor from the responsibility for proper fitting and construction of the Work, nor from furnished materials and Work required by the Contract which may not be indicated on the reviewed Submittals.

3.12.11 Submittals shall be in English, be of good quality, and be of a size and scale to clearly show all necessary details. Submittals shall show in detail the size, sections and dimensions of all members; the arrangement and construction of all connections, joints and other pertinent details; and all holes, straps and other fittings required by other Separate Contractors for attaching their Work. When required by District, Construction Manager or Design Consultant, engineering computations shall be submitted. Contractor shall be responsible for delivering duplicates of Submittals to all other persons whose Work is dependent thereon.

3.12.12 Contractor shall, at all times, maintain at the Site a complete file of all District, Construction Manager or Design Consultant-reviewed Submittals.

### **3.13 TRADE NAMES, SUBSTITUTIONS**

3.13.1 Except as otherwise noted and permitted by law, whenever in the Contract Documents any material or process is indicated or specified by two or fewer patents, proprietary names, brand names and/or manufacturers, such specification shall be deemed pursuant to Public Contract Code 3400 to be followed by the words "or approved equal".

3.13.2 Contractor shall have ten (10) Days after submission of the Bid to submit data substantiating substitution of "or equal" items. District, with the advice of the Design Consultant, will determine whether the proposed brand or item is equal in quality and utility to that specified in the Contract Documents, and its decision shall be final. District, Construction Manager or Design Consultant may require the submission of samples, formulae, and/or statements of physical properties for consideration in determining equality of the material or process in question. No proposal for an equal will be considered complete unless accompanied by complete information and descriptive data necessary to determine the equality of the offered equal.

3.13.3 If Contractor requests use of substitute material or process, it shall be incumbent upon Contractor to furnish sufficient evidence to support the claim of equality to the satisfaction of District, Construction Manager or Design Consultant.

3.13.4 If District accepts for use in the Project a substitute material or process which in the opinion of District, Construction Manager or Design Consultant is not the equal of that specified, a Change Order shall be issued issuing a credit

to District for the difference in value.

3.13.5 Substitutions by Contractor that are incorporated into the Work without the prior review and Approval by District, Construction Manager or Design Consultant in accordance with the requirements of the Contract Documents shall be deemed to be Defective Work.

3.13.6 The specified Construction Contract completion time shall not be affected by any circumstance developing from the substitution provisions of this Article 3.13.

### **3.14 DAILY REPORTS BY CONTRACTOR**

3.14.1 At the end of each working day, Contractor shall submit a daily report to the Construction Manager (on a form provided by or accepted by the Construction Manager) listing:

- (i) At the end of each working day, Contractor shall submit a daily report to the Construction Manager (on a form provided by or accepted by the Construction Manager) listing: Labor - Names of workers, classification, and hours worked;
- (ii) Material - Description and list of quantities of materials used;
- (iii) Equipment - Type of equipment, size, identification number, and hours of operation, including loading and transportation, if applicable;
- (iv) Inspection and Testing Activities - Name, District or company and items involved;
- (v) Areas of Work - The areas of the Site on which Work was performed and a detailed description of the stage, status and progress of the Work in each such area at the beginning and end of the day;
- (vi) Accidents, Delays, Defective Work - Description in detail of any injuries to workers, accidents, Delays, or Defective Work that were encountered; and
- (vii) Other Services and Expenditures - Description in such detail as District may require of other services and expenditures.

3.14.2 Reports by Subcontractors and Sub-subcontractors that comply with the requirements of this Article 3.14 shall also be submitted to the Construction Manager through Contractor at the end of each working day.

3.14.3 Submission of daily reports by Contractor, Subcontractors and Sub-subcontractors, of every Tier performing Work on the Site shall be a condition precedent to Contractor's right to payment under the Contract.

3.14.4 Facts, notice or information contained in daily reports of Contractor or its Subcontractors or Sub-subcontractors, whether known or not known to District or Construction Manager, shall under no circumstances be considered evidence of compliance by Contractor with any of the specific written notice requirements of the Contract Documents.

### **3.15 CUTTING AND PATCHING**

3.15.1 Contractor shall do all cutting, fitting, or patching of the Work required to make all parts of the Work join properly and to allow the Work to join the work of Separate Contractors shown in, or reasonably implied by, the Contract Documents.

3.15.2 Contractor shall not endanger the Work, the Project, Existing Improvements, or adjacent property by cutting, digging, or otherwise. Contractor shall not cut or alter the work of any Separate Contractor without the prior consent of District.

3.15.3 In all cases, cutting shall be performed under the supervision of competent workers skilled in the applicable trade and shall cause the openings to be cut as small as possible to minimize unnecessary damage.

### **3.16 ACCESS TO THE WORK**

3.16.1 District, Construction Manager, Design Consultant, their consultants and other persons authorized by District shall at all times have access to the Work wherever it is in preparation or progress. Contractor shall provide safe and proper facilities for such access and for inspection.

3.16.2 District may, at any time, and from time to time during the performance of the Work, enter the Project for the purpose of installing any necessary other work by District labor or other contracts or for any other purpose. Contractor shall cooperate with District and not interfere with other work being done by or on behalf of District.

### **3.17 ROYALTIES AND PATENTS**

3.17.1 Contractor shall pay all royalties and license fees required for the performance of the Work. Contractor shall immediately notify District if it learns of any circumstances that may constitute an infringement of patent rights and shall defend and indemnify District and the members of the Project Team in accordance with Article 3.21 against Losses, liabilities, suits or Claims resulting from Contractor's or any Subcontractor's or Sub-subcontractor's infringement of patent rights.

### **3.18 PERMITS AND LICENSES**

3.18.1 Contractor and all Subcontractors shall obtain and be responsible for the cost of all permits and applications related to the construction of the Project.

### **3.19 DIFFERING SITE CONDITIONS**

3.19.1 Save and except as permitted for Differing Site Conditions as defined in this Article 3.19, Contractor agrees to solely bear the risk and the additional cost and Delay of all concealed or unknown conditions at the Site or in Existing Improvements, without adjustment to the Contract Sum or Contract Time.

3.19.2 Differing Site Conditions are those conditions encountered at the Site or in Existing Improvements that are (1) subsurface or concealed conditions which differ materially from those indicated in the Contract Documents; or (2) unknown physical conditions at the Site, of an unusual nature, differing materially from those ordinarily encountered and generally recognized as inherent in the Work of the character provided for in the Contract Documents.

3.19.3 If Contractor encounters conditions it believes constitute Differing Site Conditions, then notice of such conditions shall be immediately reported to District and the Construction Manager followed within twenty-four (24) hours by a written notice stating a detailed description of the conditions encountered.

3.19.4 District shall promptly investigate Contractor's report of Differing Site Conditions. If District finds that Differing Site Conditions exist, in accordance with this Article 3.19, an adjustment shall be made in the Contract Sum and Contract Time in such amount as District approves.

3.19.5 If Contractor intends to seek an adjustment to the Contract Sum or Contract Time based upon Differing Site Conditions, it must, within seven (7) Days after it first discovered, or should have discovered in the exercise of diligence and care, the existence of such Differing Site Conditions, submit a written statement setting forth a detailed cost breakdown in the form required by Article 7.2 setting forth the basis of Contractor's calculation of the costs saved or incurred, detailed information demonstrating the effect on the Construction Schedule in the same manner as required by the Contract Documents for obtaining approval of extensions of time, identification of the Bid Documents that formed the basis of Contractor's Bid estimate to perform the Work affected by such conditions and a complete and detailed explanation of the factual basis for the request.

3.19.6 Failure by Contractor to strictly comply with the requirements of this Article 3.19 concerning the timing and content of any notice of Differing Site Conditions or request for adjustment in Contract Sum or Contract Time based on Differing Site Conditions shall be deemed a waiver of any right by Contractor for an adjustment in the Contract Sum or Contract Time by reason of such conditions.

3.19.7 No Claim by Contractor for additional compensation for Differing Site Conditions shall be allowed if asserted after final payment under the Construction

Contract.

### **3.20 INSPECTIONS**

3.20.1 In order to allow for inspection by District and other agencies, or any inspection required elsewhere in the Special Provisions and Technical Specifications, Contractor shall notify District in writing three (3) Days in advance of the permanent concealment of any materials or Work.

3.20.2 Whenever Contractor desires to carry on the Work of this Construction Contract at hours other than 7:00 AM to 6:00 PM, Monday through Friday and from 9:00 AM to 5:00 PM on Saturdays, it shall request authorization in writing from District for such Work at least twelve (12) Days in advance and, if approved to proceed, Contractor agrees to pay overtime reimbursement of costs, of such required inspector(s) and the Construction Manager, Design Consultant and/or other District consultants whose presence is necessary and requested by District.

3.20.3 If any Work is concealed or performed without the prior notice specified above, then the Work shall be subject to such tests or exposure as may be necessary to prove to District that the materials used and the Work done are in conformity with the Contract Documents. All labor and equipment necessary for exposing and testing shall be furnished by Contractor at its expense. Contractor shall replace, at its own expense and without reimbursement by District, any materials or Work damaged by exposure and any faulty materials or work evidenced by such exposure or testing.

3.20.4 When, in order to comply with the intent of the Contract Documents, inspection must be made at the plant or mill of the manufacturer or fabricator of material or equipment, Contractor shall notify District a sufficient length of time in advance to allow for arrangements to be made for such inspection.

3.20.5 Any inspection or approval by any representative or agent of District will not relieve Contractor of the responsibility of incorporating into the Work only those materials which conform to the Contract Documents, and any nonconforming materials all be removed from the Site whenever identified.

3.20.6 When Contractor believes it has achieved either Substantial or Final Completion of the Work, Contractor shall notify District and the Construction Manager in writing and request a Substantial or Final Completion inspection of the Work. District, Design Consultant and Construction Manager will make such inspection as soon thereafter as possible.

### **3.21 INDEMNIFICATION, STOP NOTICES**

3.21.1 Contractor shall fully comply with the Indemnification provision of the Construction Contract.

3.21.2 Contractor shall take steps to assure that a right of indemnification is included in all subcontracts, purchase orders and other contracts entered into by Subcontractors and Sub-subcontractors, of every Tier, for the Project that afford the same coverage, benefits and protections as provided for in Article 3.21.1.

3.21.3 Nothing set forth in the Contract Documents shall be construed to give rise to any express or implied right in favor of Contractor for indemnity or contribution.

3.21.4 Contractor shall not permit any stop notices or other claims, valid or invalid, to be served, filed, recorded or otherwise imposed on District or on any part of the Work or the property on which the Work is performed. If any stop notice or other claim is served, filed or recorded in connection with the Work, District shall have the option, in its sole discretion, to require that Contractor immediately and at its own expense obtain a bond executed by a good and sufficient surety, in accordance with the California Civil Code, Section 3196, in a sum equal to one hundred twenty-five percent (125%) of the amount of such stop notice or claim. Such bond shall guarantee the payment of any amounts which the claimant may recover on the stop notice or claim, together with the claimant's costs of suit in any action to enforce such stop notice or claim if the claimant recovers therein. This remedy shall be in addition to all other rights and remedies of District under the Contract Documents and applicable law, including, without limitation, the right to withhold funds from sums due to Contractor.

## **3.22 PARKING**

3.22.1 Contractor shall provide and maintain suitable parking areas, for use by all construction workers and others performing work or furnishing services in connection with the Project, as required to avoid any need for parking personal vehicles where they may interfere with public traffic, construction activities or public parking.

## **3.23 USE OF THE PROJECT SITE AND CLEAN UP**

3.23.1 Contractor shall confine operations at the Site to areas permitted by Applicable Code Requirements and the Contract Documents. Contractor shall not encumber the Site with materials or equipment so that Separate Contractors' work is hindered or impeded due to such encumbrances.

3.23.2 Contractor shall, during performance of the Work, keep the Site and surrounding area free from the accumulation of excess dirt, dust, waste materials, water and rubbish caused by Contractor or any Subcontractors. Contractor shall continuously remove all excess dirt, waste material, water and rubbish caused by Contractor and all tools, equipment, machinery and surplus materials from the Site and surrounding area at the completion of the Work. Adequate cleanup will be a condition for progress payments.

3.23.3 Personnel of Contractor, Subcontractors, and Sub-subcontractors shall

(v) General Conditions



not occupy, live upon, or otherwise make use of the Site during any time that Work is not being performed at the Site, except as otherwise provided in the Contract Documents.

3.23.4 Upon Final Completion of the Work, Contractor shall remove all construction facilities, appurtenances, tools, material and other articles from the Site. The entire area, including all fixed equipment, floors, surfaces and hardware shall be cleaned and restored to their original condition in accordance with the Special Provisions and Technical Specifications.

3.23.5 In addition to water sprinkling, temporary enclosures and anti-dust sweeping compounds should be used to limit dust and dirt rising and to keep the Site clean.

3.23.6 Construction materials shall be neatly stacked by Contractor when not in use. Dusty materials in piles or in transit shall be covered to prevent suspension of the dirt in the air. Contractor shall promptly remove splattered concrete, asphalt, oil, paint, corrosive liquids and cleaning solutions from the affected surfaces to prevent marring or other damage.

3.23.7 Volatile wastes shall be properly stored in covered metal containers and removed daily. All other trash receptacles shall be promptly emptied when full. Contractor shall promptly and legally transport and dispose of removed and demolished items and waste materials not identified to be recycled or reused in a manner complying with local ordinances and anti-pollution laws. No rubbish or waste materials shall be burned, buried, or otherwise disposed of on the Site.

3.23.8 Sanitary facilities shall be of reasonable capacity, properly maintained throughout the construction period, and obscured from public view to the greatest practical extent. Contractor shall enforce the use of such sanitary facilities by all personnel at the Site. Sanitary facilities shall be on a portable trailer and shall be removed from the Site at the end of each workday. For sewer lining projects, Contractor shall provide additional sanitary facilities on a portable trailer to be used by the residents during lining installation (one sanitary facility per each 30 meters [100 feet]). Contractor shall remove those sanitary facilities as soon as relief holes are cut and notices of completion are delivered.

## **3.24 ENVIRONMENTAL CONTROLS**

3.24.1 AIR POLLUTION CONTROL. Contractor shall comply with all air pollution control rules, regulations, ordinances and statutes which apply to any work performed pursuant to the Contract, including any air pollution control rules, regulations, ordinances and statutes, specified in the California Government Code, Section 11017, or any other applicable law. In the absence of any applicable air pollution control rules, regulations, ordinances or statutes governing solvents, all solvents, including but not limited to the solvent portions of paints, thinners, curing compounds and liquid asphalt used on the Project shall

comply with the applicable material requirements of the San Luis Obispo County Air Pollution Control District. All containers of paint, thinner, curing compound or liquid asphalt shall be labeled to indicate that the contents fully comply with said requirements. Material to be disposed of shall not be burned.

.1 Mold. If any material susceptible to microbial growth becomes wet during the construction phase, that material should be carefully removed from the construction Site to prevent further contamination of the indoor air.

.2 VOC's. Construction materials that emit low levels of volatile organic compounds (VOC) shall be used to improve indoor air quality. Adequate ventilation of packaged dry products shall be used prior to installation. Contractor is responsible to ventilate the building during the application of wet products (e.g., paints, glues, sealants), which release their highest levels of VOC's during the curing period immediately after the application. Also, wet products shall be applied before installing materials that act as "sinks" such as carpets, fabric, ceiling tiles, movable partitions, furniture, etc. in order to reduce the chance of the "sinks" absorbing contaminants and slowly releasing them into the building over time.

.3 Off-Gassing. Contractor is responsible for identifying specific materials that require more complex ventilation to accelerate off-gassing. In addition to paints, glues and sealants, those materials that generally require temporary ventilation include, without limitation: composite wood products, plastics, waterproofing, insulation, fireproofing, caulking, acoustical ceilings, resilient flooring and wood preservatives.

.4 Barriers. Barriers shall be used to prevent the migration of airborne pollutants from areas under construction and to mitigate any construction noise that may disrupt occupant activities. If effective controls for pollution emissions cannot be practically implemented, activities involving significant airborne pollutants shall be scheduled during off-hours at Contractor's expense. The Site shall be ventilated with fresh outside air during and immediately after the noxious activity.

.5 Exhaust. Contractor shall install a temporary exhaust in a construction area to prevent contaminated air from entering the building's return-air system, including, without limitation:

- (i) Removing windows in a space.
- (ii) Using available or dedicated exhaust systems (e.g., kitchen or toilet exhaust) that are not tied into the building's overall return-air system.

The building shall be flushed with full outdoor air for seven (7) Days prior to occupancy. Full capacity of the HVAC system shall be used for at least 2.5 ACH

(air changes per hour), provided by temporary fans. During this time, the interiors shall be thoroughly cleaned, the HVAC ducts vacuumed, and air and HVAC system filters replaced.

3.24.2 TEMPORARY WATER, LIGHT AND POWER. Water for any purpose shall be obtained by Contractor, at its expense, from District. Contractor is to contact the Construction Manager for a phone number and contact person. In no case may Contractor obtain water from unmetered fire hydrants. The costs of obtaining water shall be included in the prices paid for the various contract items of work included and no additional compensation will be allowed therefore, unless otherwise specified in these Contract Documents. Contractor should be aware that there is a penalty for taking water from an unmetered fire hydrant. This amount shall be deducted from the payment due Contractor.

### 3.24.3 WATER POLLUTION CONTROL.

.1 Contractor shall use “Best Available Technology” and “Best Management Practices” to prevent the pollution of drains and watercourses by discharges of materials other than uncontaminated storm water. Prohibited discharge include storm water, discharge that may threaten to cause pollution, contamination or nuisance, sanitary waste, sediment and debris from erosion and other substances resulting from construction activities. Sanitary wastes will not be permitted to enter any drain or watercourse other than sanitary sewers. No sediment, debris or other substance will be permitted to enter sanitary sewers.

.2 Contractor to provide effective and continuous control of water pollution, including where Work is in small or multiple units, on an out of phase schedule or with modified construction procedures. Contractor shall determine which methods are most effective in achieving control of water pollution as a result of Contractor's operations. Contractor shall coordinate water pollution control work with all other Work performed by Contractor and Separate Contractors.

.3 Before starting any Work on the Project, Contractor shall submit to the Construction Manager for acceptance a program for effective control of water pollution. Such program shall show the schedule and detailed description for the pollution and erosion control work or practices included in the Construction Contract and for all water pollution control measures which Contractor proposes to take in connection with construction of the Project to minimize the effects of their operations upon adjacent streams and other bodies of water. Contractor shall not perform any clearing and grubbing or earthwork on the Project, other than that specifically authorized in writing by the Construction Manager, until such program has been approved by District or Construction Manager. Contractor shall revise and bring up to date said water pollution control program at any time the Construction Manager makes written request for such revisions.

.4 The Construction Manager will notify Contractor within seven (7) Days

of its learning of the acceptance or rejection of any submitted or revised water pollution control program.

.5 District shall not be liable to Contractor for failure to accept all or any portion of any originally submitted or revised water pollution control program, or for any Delays to the Work due to Contractor's failure to submit an acceptable water pollution control program. Contractor assumes sole responsibility for all costs associated with treatment of water polluted as a result of Contractor's Site activities, whether treatment is initiated by Contractor or District.

.6 Contractor may request the Construction Manager to waive the requirement for submission of a written program for control of water pollution when the nature of Contractor's operation is such that pollution discharge or erosion is not likely to occur. Waiver of this requirement will not relieve Contractor from responsibility for compliance with the other provisions of this Section. Waiver of the requirement for a written program for control of water pollution will not preclude District requiring submittal of a written program at a later time if the Construction Manager deems it necessary because of the effect of Contractor's operations.

.7 Where erosion damage which will cause water pollution is probable due to the nature of the material or the season of the year, Contractor's operation shall be so scheduled that permanent erosion control features will be installed concurrently with or immediately following grading operations.

.8 All water pollution control work required elsewhere in the Contract Documents which may be accomplished under the various contract items of Work will be measured and paid for as provided in said items of Work elsewhere in these Contract Documents.

.9 All water pollution control work performed in accordance with the accepted program which is not otherwise required under the Construction Contract and which is ordered by the Construction Manager will be paid for as Extra Work as provided for in the General Conditions. Except as otherwise provided in Article 3.24.3 or elsewhere in the Contract Documents, full compensation for conforming to the requirements of Article 3.24.3 shall be considered as included in the prices paid for the various contract items of Work and no additional compensation will be allowed therefore.

3.24.4 URBAN RUNOFF. The following Best Management Practices which address the problem of urban runoff shall apply to all projects undergoing construction in District. The Best Management Practices list set forth below is required by District, and shall apply at the time of demolition of an existing structure or commencement of construction until receipt of a certificate of occupancy or certificate of completion:

.1 Runoff, sediments and construction waste from construction sites and

(v) General Conditions

parking areas shall not leave the site.

.2 Any sediments or other materials which are tracked off the Site shall be removed the same day. When determined necessary by the Construction Manager to provide temporary pollution control measures, a temporary sediment barrier shall be installed.

.3 On an emergency basis only, plastic covering may be utilized to prevent erosion of an otherwise unprotected area, along with runoff devices to intercept and safely convey the runoff. Excavated soil shall be located on the Site in a manner that eliminates the possibility of sediment running into the street or adjoining properties. Undocumented fills shall be covered until the soil is either used or removed.

.4 No washing of construction or other industrial vehicles shall be allowed adjacent to the Site. No runoff from washing vehicles on the Site is allowed to leave the Site.

.5 Drainage controls shall be utilized as needed, depending on the extent of proposed grading and topography of the Site, including, but not limited to the following: (i) detention ponds, sediment ponds or infiltration pits; (ii) dikes, filter berms or ditches; and (iii) down drains, chutes or flumes.

3.24.5 STORMWATER POLLUTION. To avoid stormwater pollution, Contractor shall plan roadwork and pavement construction as follows:

(i) Apply concrete, asphalt, and seal coat during dry weather to prevent contaminants from contacting stormwater runoff.

(ii) Cover storm drain inlets and personnel access holes when paving or applying seal coat, slurry seal, fog seal, etc.

(iii) Always park paving machines over drip pans or absorbent materials, since they tend to drip continuously.

(iv) When making saw-cuts in pavement, use as little water as possible. Cover each catch basin completely with filter fabric during the sawing operation and contain the slurry by placing straw bales, sand bags, or gravel dams around the catch basin. After the liquid drains or evaporates, shovel or vacuum the slurry residue from the pavement or gutter and remove from the Site.

3.24.6 DRAINAGE CONTROL. Contractor shall provide for the drainage of storm water and such water as may be applied or discharged on the Site in performance of the Work. Drainage facilities shall be adequate to prevent damage to the Work, Site and adjacent property. Also drainage facilities shall be constructed to minimize the potential pollution to the ocean.

(v) General Conditions

Existing drainage channels and conduits shall be cleaned, enlarged or supplemented as necessary to carry all increased runoff attributable to Contractor's operations. Dikes shall be constructed as necessary to divert increased runoff from entering adjacent property (except in natural channels), to protect District's private property and utility owner's facilities and the Work, and to direct water to drainage channels or conduits. Retention of drainage on the Site shall be provided as necessary to prevent downstream flooding.

### 3.24.7 SOUND CONTROL.

.1 Contractor shall comply with all local sound control and noise level rules, regulations and ordinances which apply to any Work performed pursuant to the Construction Contract, except as modified in the Special Provisions and Technical Specifications.

.2 Each internal combustion engine, used for any purpose on the job or related to the job, shall be equipped with a muffler of a type recommended by the manufacturer. No internal combustion engine shall be operated on the Project without said muffler. The noise level from Contractor's operations, between the hours of 7:00 A.M. and 6:00 P.M., shall not exceed 86 DBA at a distance of 15 meters (50 feet). This requirement in no way relieves Contractor from responsibility for complying with local ordinances regulating noise level.

.3 The noise level requirement shall apply to all equipment on the job or related to the job, including but not limited to trucks, transit mixers or transient equipment that may or may not be owned by Contractor. The use of loud sound signals shall be avoided in favor of light warnings except those required by safety laws for the protection of personnel.

.4 Prior to starting construction, all equipment to be used on the Project shall be inspected and tested for compliance with the requirements of this Project. Sound blankets or other sound mitigation equipment approved by the Construction Manager shall be required to bring equipment into compliance with the requirements of this Project.

.5 Full compensation for conforming to the requirements of this provision shall be considered as included in the prices paid for the various contract items of Work involved and no additional compensation will be allowed therefor.

3.24.8 SPECIAL HAZARDOUS SUBSTANCES AND PROCESSES. Contractor acknowledges that it is aware of and in compliance with the provisions of the Hazard Communication Standards (California Code of Regulations, Title 8, Section 5194). Contractor shall, at the request of the Construction Manager, demonstrate that Contractor is in complete compliance with the Hazard Communication Standards. In addition, Contractor shall, at the request of the Construction Manager, provide to the Construction Manager a material safety data sheet and a copy of the product label for any product handled or used by

Contractor on District property or in an area where a District employee is working. Contractor shall contact the District's "Household Hazardous Waste Facility" regarding the intent to dispose of any materials containing asbestos or any petroleum-contaminated soil.

---

## **ARTICLE 4 – ADMINISTRATION OF THE CONTRACT**

### **4.1 CONTRACT ADMINISTRATION BY DISTRICT, DESIGN CONSULTANT AND CONSTRUCTION MANAGER**

4.1.1 District and the Construction Manager will provide administration of the Construction Contract as provided in the Contract Documents.

4.1.2 No actions taken by District, Construction Manager or Design Consultant shall relieve Contractor of its obligations as described in the Contract Documents.

4.1.3 The Construction Manager will be present on the Site, as is convenient or necessary in the sole discretion of the Construction Manager, during the performance of the Work primarily for the purposes of providing administration, inspection and expediting communications between District, Design Consultant and Contractor.

4.1.4 Neither District, Design Consultant nor Construction Manager will have control over, will be in charge of, or will be responsible for construction means, methods, techniques, safety, sequences or procedures or for safety precautions and programs in connection with the Work, all of which are the sole responsibility of Contractor.

4.1.5 Unless otherwise provided in the Contract Documents or when direct communications have been specifically authorized, communications between Contractor and District or Design Consultant shall be in writing through Construction Manager. Communications by Contractor, Subcontractors and Sub-subcontractors with Separate Contractors shall be through the Construction Manager. Contractor shall not rely on oral or other non-written communications.

4.1.6 Based on the Construction Manager's Site visits and evaluations of Contractor's Applications For Payment, the Construction Manager will review and recommend to District for District approval the amounts, if any, due Contractor.

4.1.7 Construction Manager will make recommendations to District to reject the Work, or any portion thereof, which does not conform to the Contract Documents. District alone shall have the authority to stop the Work or any portion thereof. Whenever District considers it necessary or advisable, District will have the authority to require additional inspection or testing of the Work in accordance with the Contract Documents, whether or not such Work is fabricated, installed or completed. However, no authority of District conferred by the Contract Documents nor any decision made in good faith either to exercise or not exercise such authority, nor any recommendation by the Construction Manager, shall give rise to a duty or responsibility of District or the Construction Manager to Contractor or its Subcontractors or Sub-subcontractors, of any Tier.

4.1.8 Construction Manager will have the authority to do the following:

(v) General Conditions



- (i) Conduct inspections in connection with Beneficial Occupancy or beneficial use of the District;
- (ii) Assist District in determining the dates of Substantial Completion and Final Completion;
- (iii) Review any records, written warranties and related documents required by the Contract Documents and assembled by Contractor; and
- (iv) Make recommendations to District for issuance of final payment upon Contractor's compliance with the requirements of the Contract Documents.

4.1.9 District, with the assistance of recommendations from the Design Consultant and/or Construction Manager, shall be the ultimate interpreter of the requirements of the Contract Documents and the judge of performance thereunder by Contractor. Such decisions by District will be final and binding upon Contractor.

## **4.2 CLAIMS**

As set forth in the Section 1.1.18, a Contractor Claim means a separate demand by a Contractor sent by registered mail or certified mail with return receipt requested, for one or more of the following: (A) a time extension, including, without limitation, for relief from damages or penalties for delay assessed by the District; (B) payment by the District of money or damages arising from work done by, or on behalf of, the Contractor pursuant to the Construction Contract and payment for which is not otherwise expressly provided or to which the claimant is not otherwise entitled; (C) payment of an amount that is disputed by the District.

### **4.2.1 Time period for submission of Contractor Claim.**

- (i) If a Contractor Claim involves an adjustment to the Contract Sum or to the Contract Time due to Extra Work, then the Claim arises upon issuance of a decision denying, in whole or in part, Contractor's Change Order Request. All other Claims arise when Contractor discovers, or should have discovered, the circumstances giving rise to the Claim (even if Contractor has not yet been damaged or delayed).
- (ii) A Contractor Claim that does not involve an adjustment to the Contract Sum or Contract Time for Extra Work may be asserted if, and only if, Contractor gives written notice of intent to file the Claim within five (5) Days of the date the Claim arises under Article 4.2.1. A written notice of intent to file a Claim shall be valid if, and only if, it identifies the event or condition giving rise to the Claim, states its probable effect, if any, with respect to Contractor's entitlement to an adjustment of the Contract Sum or Contract Time, and complies with the requirements of Article 4.2.3.

- (v) General Conditions

4.2.2 The claimant shall furnish reasonable documentation to support a Contractor Claim. The documentation is to include the following:

(i) A statement that it is a Contractor Claim and a request for a decision on the Contractor Claim;

(ii) A detailed description of the act, error, omission, Differing Site Condition, event or other circumstance giving rise to the Contractor Claim; and

(iii) If the Contractor Claim involves an adjustment to the Contract Sum or Contract Time for Extra Work, a statement demonstrating that a Change Order Request was submitted in a timely manner as required by Article 7.2. If the Contractor Claim does not involve an adjustment to the Contract Sum or Contract Time for Extra Work, a statement demonstrating that a notice of intent to file the Contractor Claim was submitted in a timely manner as required by Article 4.2.2.

(iv) A detailed justification for any remedy or relief sought by the Contractor Claim, including, without limitation:

a. A detailed cost breakdown in the form required for submittal of Change Order Requests and subject to the prohibition in Article 7.2.14 relating to calculations based on total cost methodology.

b. Copies of actual job cost records demonstrating that the costs have been incurred.

c. If the Contractor Claim is based on an error, omission, conflict or ambiguity in the Contract Documents: (i) a sworn statement by Contractor and any Subcontractors or Sub-subcontractors involved in the Claim, to the effect that the error, omission, conflict or ambiguity was not discovered prior to submission of the Bid, or (ii) if not discovered, a statement demonstrating that the error, omission, conflict or ambiguity could not have been discovered by Contractor, its Subcontractors or Sub-subcontractors in exercise of the degree of care required of them under the Contract Documents for review of the Bid Documents prior to submission of the Bid.

(v) If the Contractor Claim involves a request for adjustment of the Contract Time, written documentation demonstrating that Contractor has complied with the requirements of the Contract Documents pertaining to proving the right to an extension of time and demonstrating that Contractor is entitled to an extension of time under the Contract Documents.

(vi) A written certification signed by a responsible managing officer of Contractor's organization, who has the authority to sign subcontracts and purchase orders on behalf of Contractor and who has personally investigated

(v) General Conditions

and confirmed the truth and accuracy of the matters set forth in such certification, in the following form:

*I hereby certify under penalty of perjury under the laws of the State of California that I am a managing officer of [Contractor's name] and that I have reviewed the Claim presented herewith on Contractor's behalf and/or on behalf of [Subcontractor's/Sub-subcontractor's name(s)] and that the following statements are true and correct.*

*(i) The facts alleged in or that form the basis for the Claim are true and accurate; and,*

*(ii) Contractor does not know of any facts or circumstances, not alleged in the Claim, that by reason of their not being alleged render any fact or statement alleged in the Claim materially misleading; and,*

*(iii) Contractor has, with respect to any request for money or damages alleged in or that forms the basis for the Claim, reviewed the job cost records (including those maintained by Contractor and by any Subcontractor or Sub-subcontractor, of any Tier, that is asserting all or any portion of the Claim) and confirmed with reasonable certainty that the Losses or damages suffered by Contractor and/or such Subcontractor or Sub-subcontractor were in fact suffered in the amounts and for the reasons alleged in the Claim; and,*

*(iv) Contractor has, with respect to any request for extension of time or claim of Delay, disruption, hindrance or interference alleged in or that forms the basis for the Claim, reviewed the job schedules (including those maintained by Contractor and by any Subcontractor or Sub-subcontractor, of any Tier, that is asserting all or any portion of the Claim) and confirmed on an event-by-event basis that the delays or disruption suffered by Contractor and/or such Subcontractor or Sub-subcontractor were in fact experienced for the durations, in the manner, and with the consequent effects on the time and/or sequence of performance of the Work, as alleged in the Claim; and,*

*(v) Contractor has not received payment from District for, nor has Contractor previously released District from, any portion of the Claim.*

*Signature:*

*Name:*

*Title:*

*Company:*

*Date:*

4.2.3 Notwithstanding the making of any Contractor Claim or the existence of any dispute regarding any Contractor Claim, unless otherwise directed by District, Contractor shall not delay, slow or stop performance of the Work, but shall diligently proceed with performance in accordance with the Contract Documents and District will continue to make payments as required by the Contract Documents.

4.2.4 All Contractor Claims and supporting documentation and certifications must be filed within thirty (30) Days after the Contractor Claim arises. No Contractor Claims shall be filed after the final payment has been issued unless otherwise permitted by law.

4.2.5 All Contractor Claims and supporting documentation must be sent by registered mail or certified mail with return receipt requested.

4.2.6 Time Period for Response.

(i) Upon receipt of a Contractor Claim pursuant to this Section 4.2, the District shall conduct a reasonable review of the claim and, within a period not to exceed forty-five (45) days, shall provide the claimant a written statement identifying what portion of the claim is disputed and what portion is undisputed. Upon receipt of a claim, the District and Contractor may, by mutual agreement, extend the time period provide in this Section 4.2.6(i).

(ii) If the District needs approval from its governing body to provide the claimant with a written statement identifying the disputed portion and the undisputed portion of the claim, and the governing body does not meet within the forty-five (45) days or within the mutually agreed to extension of time following receipt of a claim sent by registered mail or certified mail, return receipt requested, the District shall have up to three (3) days following the next duly publicly noticed meeting of the governing body after the forty-five (45) day period, or extension, expires to provide the claimant a written statement identifying the disputed portion and the undisputed portion.

(iii) Any payment due on an undisputed portion of the claim shall be processed and made within 60 days after the District issues its written statement. If the District fails to issue a written statement, Section 4.2.9 shall apply.

4.2.7 Meet and Confer Conference. If the claimant disputes the District's written response, or if the District fails to respond to a claim issued pursuant to Section 4.2 within the time prescribed, the claimant may demand in writing and an informal conference to meet and confer for settlement of the issue in dispute. Upon receipt

(v) General Conditions

of a demand in writing sent by registered mail or certified mail, return receipt requested, the District shall schedule a meet and confer conference within 30 days for settlement of the dispute.

#### 4.2.8. Mediation.

(i) Within ten (10) business days following the conclusion of the meet and confer conference, if the claim or any portion of the claim remains in dispute, the District shall provide the claimant a written statement identifying the portion of the claim that remains in dispute and the portion that is undisputed. Any payment due on an undisputed portion of the claim shall be processed and made within sixty (60) days after the public entity issues its written statement. Any disputed portion of the claim, as identified by the contractor in writing, shall be submitted to nonbinding mediation, with the District and the claimant sharing the associated costs equally. The District and the claimant shall mutually agree to a mediator within ten (10) business days after the disputed portion of the claim has been identified in writing. If the parties cannot agree upon a mediator, each party shall select a mediator and those mediators shall select a qualified neutral third party to mediate with regard to the disputed portion of the claim. Each party shall bear the fees and costs charged by its respective mediator in connection with the selection of the neutral mediator. If mediation is unsuccessful, the parts of the claim remaining in dispute shall be subject to applicable procedures outside this section.

(ii) For purposes of this section, mediation includes any nonbinding process, including, but not limited to, neutral evaluation or a dispute review board, in which an independent third party or board assists the parties in dispute resolution through negotiation or by issuance of an evaluation. Any mediation utilized shall conform to the timeframes in this section.

(iii) Unless otherwise agreed to by the District and the contractor in writing, the mediation conducted pursuant to this section shall excuse any further obligation under Public Contract Code Section 20104.4 to mediate after litigation has been commenced.

(iv) In the event mediation does not resolve the parties' dispute, the parties shall comply with the binding Arbitration provisions set forth in Section 14.4.4 of the Construction Contract.

4.2.9 Failure by the District to respond to a Construction Claim within the time periods described in this subdivision or to otherwise meet the time requirements of this Section 4.2 shall result in the Construction Claim being deemed rejected in its entirety. A Construction Claim that is denied by reason of the District's failure to have responded to a claim, or its failure to otherwise meet the time requirements of this section, shall not constitute an adverse finding with regard to the merits of the claim or the responsibility or qualifications of the claimant.

(v) General Conditions

4.2.10 Amounts not paid in a timely as required by this section shall bear interest at 7 percent (7%) per annum.

4.2.11 If a subcontractor or a lower tier subcontractor lacks legal standing to assert a claim against the District because privity of contract does not exist, the Contractor may present to the District a claim on behalf of a subcontractor or lower tier subcontractor. A subcontractor may request in writing, either on his or her own behalf or on behalf of a lower tier subcontractor, that the Contractor present a claim for work which was performed by the subcontractor or by the lower tier subcontractor on behalf of the subcontractor. The subcontractor requesting that the claim be presented to the District shall comply with the Agreement, including the General Conditions, and shall furnish reasonable documentation to support the Construction Claim. Within 45 days of the receipt of this written request, the Contractor shall notify the subcontractor in writing as to whether the Contractor presented the claim to the District and, if the Contractor did not present the claim, provide the subcontractor with a statement of reasons for not having done so.

4.2.12 There shall be no waiver of any of the rights set forth in this Section 4.2; provided, however, that (i) upon receipt of a Construction Claim, the parties may mutually agree to waive, in writing, mediation and proceed directly to the commencement of a civil action or binding arbitration, as applicable; and (ii) the District may prescribe reasonable Change Order, Construction Claim, and Dispute Resolution Procedures and requirements in addition to the provisions of this section, so long as the contractual provisions do not conflict with or otherwise the timeframes and procedures set forth in Public Contract Code Section 9204.

---

## **ARTICLE 5 – SUBCONTRACTORS**

### **5.1 CONTRACTOR'S AWARD OF SUBCONTRACTS**

5.1.1 Contractor shall perform, with its own employees, Work amounting to at least 50 percent of the Contract Sum except that any designated "Specialty Items" may be performed by subcontract and the amount of any such "Specialty Items" so performed may be deducted from the Contract Sum before computing the amount required to be performed by Contractor with its own employees. "Specialty Items" are identified in the Bid Documents. Where an entire item is subcontracted, the value of Work subcontracted will, where no prices are provided, be based on the unit price and when a portion of an item is subcontracted, the value of Work subcontracted will be based on the estimated percentage of the unit price. Such percentages will be determined from information submitted by Contractor, and subject to approval by the Construction Manager.

5.1.2 Unless otherwise stated in the Contract Documents, Contractor shall submit in writing, prior to entering into any subcontract agreements, the company name, address, telephone and facsimile numbers, point-of-contact and contractor's license number of all Subcontractors proposed for the Work that are changed from those previously listed in Contractor's Bid. Any Subcontractor may be disqualified if District or the Construction Manager determines that such Subcontractor fails to meet the requirements of the Contract Documents or for any other appropriate reason. If District or the Construction Manager has reasonable objections to a person or entity proposed by Contractor, Contractor shall propose an alternate party to whom District and the Construction Manager have no reasonable objection.

5.1.3 Contractor shall comply with the Subletting and Subcontracting Fair Practices Act, California Public Contract Code, Sections 4100 through 4114. Nothing herein shall be deemed to entitle Contractor, without the written approval of District, to substitute other Subcontractors for those named in Contractor's List of Subcontractors contained in the completed Bid; and, except with such approval, no such substitution shall be made. Should Contractor violate any of the provisions of the Subletting and Subcontracting Fair Practices Act, such violation shall be deemed a violation of the Construction Contract, entitling District, without limitation to any other rights or remedies under the law, to suspend or terminate the Construction Contract.

5.1.4 Except as hereinafter provided, any increase in the cost of the Work resulting from the replacement or substitution of a Subcontractor, shall be borne solely by Contractor and without any adjustment in Contract Sum or Contract Time. However, if a replacement or substitution of any Subcontractor is made as a result of a request of District or the Construction Manager for any reason other than failure of such Subcontractor to meet the requirements of the Contract Documents or a request by Contractor for substitution, the Contract Sum only,

and not the Contract Time, shall be subject to adjustment pursuant to the Change Order provisions of the Contract Documents for the amount of the increase or decrease in the original subcontract amount, with no additional sum for Contractor Markup. In such cases and at the request of District, the replacement Subcontractor shall be selected through a competitive bidding process acceptable to District.

5.1.5 Where a hearing is held pursuant to the provisions of the California Public Contract Code Division 2, Part 1 – Chapter 4 (commencing with Subparagraph 4100), by the awarding authority or a duly appointed hearing officer, District's representative shall prepare and certify a statement of all costs incurred by District for investigation and conduct of the hearing, including the costs of any hearing officer and reporter appointed. The statement shall then be sent to Contractor who shall reimburse District for such costs. If not paid separately, such reimbursement may be deducted from any money due and owing to Contractor.

## **5.2 SUBCONTRACTUAL RELATIONS**

5.2.1 Prior to the execution of each subcontract agreement, Contractor shall make available to each proposed Subcontractor, copies of the Contract Documents to which the Subcontractor will be bound, including the provisions for dispute resolution. Within thirty (30) Days of the Notice To Proceed, Contractor shall provide District with a complete listing of all Subcontractors, which shall include, but not be limited to, the Work contracted for, Subcontractor's name, address, telephone and facsimile numbers, form for doing business (i.e., sole proprietor, corporation, partnership), point-of-contact and Subcontractor's license classification and number.

5.2.2 Any part of the Work performed for Contractor by a first Tier Subcontractor shall be pursuant to a written subcontract. Each such subcontract shall require that the Subcontractor:

- (i) Perform the Work in accordance with the terms of the Contract Documents.
- (ii) Assume toward Contractor all the obligations and responsibilities which Contractor assumes towards District by the Contract Documents.
- (iii) Preserve and protect the rights of District under the Contract Documents with respect to the Work to be performed by the Subcontractor so that subcontracting thereof will not prejudice such rights.
- (iv) Waive all rights that the Subcontractor may have against District for damages caused by fire or other perils covered by builder's risk property insurance carried by Contractor or District, except for such rights Subcontractor may have to the proceeds of such insurance held by District under Article 11 of these General Conditions.

(v) General Conditions



(v) Afford District and entities and agencies designated by District the same rights and remedies with respect to access to and the right to audit and the right to copy at District's cost all of the Subcontractor's books, records, contracts, correspondence, instructions, drawings, receipts, vouchers, purchase orders and memoranda relating to the Work and requiring the Subcontractor to preserve all such records and other items for a period of at least three (3) years after Final Completion.

(vi) Recognize the rights of District under Article 5.3, Contingent Assignment of Subcontracts, including, without limitation, District's right to elect to accept assignment of the subcontract and to retain Subcontractor pursuant to the terms of the subcontract, to complete the unperformed obligations under the subcontract and, if requested by District, to execute a written agreement on terms acceptable to District confirming that the Subcontractor is bound to District under the terms of the subcontract.

(vii) Submit Applications for payment, requests for Change Orders and extensions of time and Claims, and to comply with all other notice and submission requirements of the Contract Documents, sufficiently in advance to allow Contractor time to comply with its obligations under the Contract Documents.

(viii) Purchase and maintain insurance in accordance with the requirements of the Contract Documents and reserving the right to Owner to purchase, in its sole discretion, such insurance pursuant to an Owner Controlled Insurance or other form of Wrap-Up Program.

(ix) Defend and indemnify the Indemnitees listed in Article 3.21 on the same terms.

(x) Agree to participate in the dispute resolution procedures specified in the Contract, at the election of District.

5.2.3 Contractor shall promptly, after execution, furnish to District true, complete, and executed copies of all subcontracts, change orders and modifications thereto. Progress payments shall not be made for items of Work for which District has not received executed subcontracts or Change Orders.

5.2.4 Nothing contained in the Contract Documents shall create any contractual relationship between any Subcontractor and District, except when, and only to the extent that, District elects to accept the assignment of the subcontract with such Subcontractor pursuant to Article 5.3.

5.2.5 District and the Construction Manager shall have the right to communicate with Contractor's Subcontractors and Sub-subcontractors with respect to matters that are related to Contractor's performance of its obligations under the Contract Documents. Contractor shall be provided with

(v) General Conditions

a copy of all such written communications. Such communications shall not create or be interpreted as creating any contractual relationship between District or the Construction Manager and any such Subcontractor or Sub-subcontractor.

### **5.3 CONTINGENT ASSIGNMENT OF SUBCONTRACTS**

5.3.1 In the event of any suspension or termination of the Construction Contract, Contractor is hereby deemed to have assigned to District all its interest in contracts with Subcontractors now or hereafter entered into by Contractor for performance of any part of the Work. The assignment will be effective upon acceptance by District in writing and only as to those contracts which District designates in writing. District may accept, at its sole election, said assignment at any time during the course of the Work and prior to Final Completion in the event of a suspension or termination of Contractor's rights under the Contract Documents. Such assignment is part of the consideration to District for entering into the Contract with Contractor and may not be withdrawn prior to Final Completion.

---

**ARTICLE 6 -**  
**CONSTRUCTION BY DISTRICT OR BY SEPARATE CONTRACTORS**

**6.1 DISTRICT'S RIGHT TO PERFORM CONSTRUCTION AND TO AWARD SEPARATE CONTRACTS**

6.1.1 District reserves the right to award separate contracts for, or to perform with its own forces as provided for by law, construction or operations related to the Work or other construction or operations at or affecting the Site, including portions of the Work which have been deleted by modification. Contractor shall cooperate with District's forces and Separate Contractors.

6.1.2 District shall provide coordination of the activities of District forces and of each Separate Contractor with the Work of Contractor. Contractor shall participate with District and Separate Contractors in joint review of construction schedules and Project requirements when directed to do so. Contractor shall make necessary revisions to the Construction Schedule after such joint review.

6.1.3 Without limitation upon any of the rights or remedies of District under the Contract Documents or under law arising from a default by Contractor, in the event that Contractor fails to have personnel on Site to supervise the Work, District shall have the right, in its sole discretion, but not the responsibility, upon twenty-four (24) hours' telephonic notice to Contractor, to provide such supervision on a temporary basis. Contractor shall, notwithstanding District's providing such temporary supervision, remain solely responsible for all actions of its personnel and Subcontractors and shall defend and indemnify District in accordance with Article 3.21 against any Losses arising therefrom. District shall have the right, in its discretion, to deduct from the sums owing to Contractor the reasonable cost of such temporary supervision.

**6.2 MUTUAL RESPONSIBILITY**

6.2.1 Contractor shall be responsible for affording Separate Contractors reasonable opportunity for introduction and storage of their materials and equipment and performance of their activities. Contractor shall schedule and coordinate its construction and operations with the construction and operations of Separate Contractors as required by the Contract Documents.

6.2.2 If a portion of the Work is dependent upon the proper execution or results of other construction or operations by Separate Contractors, Contractor shall inspect such other construction or operations before proceeding with that portion of the Work. Contractor shall promptly report to District apparent discrepancies or defects which render the other construction or operations unsuitable to receive the Work. Unless otherwise directed by District, Contractor shall not proceed with the portion of the Work affected until apparent discrepancies or defects have been corrected. Failure of Contractor to so report within a reasonable time after discovering such discrepancies or defects shall constitute an acknowledgment

that the other construction or operations by District or Separate Contractors is suitable to receive the Work, except as to defects not then reasonably discoverable.

6.2.3 In the event of Delays, improperly timed activities or Defective Work, the costs of such occurrences shall be borne by the party responsible therefore.

6.2.4 If Contractor wrongfully causes damage to completed or partially completed construction or to property of District or Separate Contractors, Contractor shall promptly remedy damage.

6.2.5 If a dispute, or other matters in question arise between Contractor and a Separate Contractor, these occurrences shall be subject to the provisions of Section 14 (Dispute Resolution) of the Construction Contract. Contractor shall immediately notify the Construction Manager in writing and within seventy-two (72) hours of such occurrences.

### **6.3 DISTRICT'S RIGHT TO CLEAN UP**

6.3.1 If a dispute arises between Contractor and Separate Contractors as to the responsibility under their respective contracts for maintaining the Site and surrounding areas free from waste materials and rubbish, District may clean up and allocate the cost between those firms it deems, in its sole discretion, to be responsible.

---

## **ARTICLE 7 – CHANGES**

### **7.1 CHANGES**

7.1.1 District may, at any time and without notice to Contractor's sureties, order Changes in the Work without invalidating the Construction Contract and without relieving sureties of their obligations to District.

7.1.2 District shall be entitled to a deductive adjustment in the Contract Sum for Changes that involve Deleted Work that result in a reduction in the cost of Contractor's performing the Work and shall be entitled to an adjustment reducing the Contract Time for Deleted Work that results in Contractor's being able to complete the Work earlier than the Contract Time.

7.1.3 Unless such rights have been waived and provided that Contractor has complied with the requirements of the Contract Documents with respect to, without limitation, complete and timely submission of all notices, requests and supporting documentation, Contractor shall be entitled to an additive adjustment to the Contract Sum for Changes that involve Extra Work and an adjustment extending the Contract Time for Delays for which Contractor is entitled under the Contract Documents to an extension of time.

7.1.4 District shall have the right to require performance of Changes that result in Extra Work on a lump sum basis, a unit price basis or a time and material basis, all as hereinafter more particularly described.

7.1.5 Changes may be ordered by District or the Construction Manager in writing by issuance of an agreed or unilateral Change Order or a Field Order. Contractor shall not be entitled to an adjustment of the Contract Sum or Contract Time for Changes that are not authorized by a Change Order or Field Order signed by District or Construction Manager. It is of essence to this agreement that all Changes in the Work that are the basis of an adjustment to the Contract Sum or Contract Time must be authorized in advance, in writing, by District or Construction Manager. Accordingly, no verbal directions, course of conduct between the parties or express or implied Acceptance of Changes or Work, and no claim that the Owner has been unjustly enriched (whether or not there has been such enrichment) shall be the basis for an adjustment to the Contract Sum or Contract Time if Contractor has not obtained advance written authorization to perform the Change in the manner required by this provision.

7.1.6 District reserves the absolute right to make whatever Changes that it determines in its sole discretion are necessary and in its best interests and under no circumstances shall the number (individual or cumulative value) or scope of Changes become a basis for Contractor to claim that the Construction Contract has been rescinded, terminated, abandoned or should be reformed nor shall such circumstances be the basis for Contractor, or any Subcontractor or Sub-subcontractor, of any Tier, to recover any compensation or damages not

permitted by, or in excess of that allowed under, the Contract Documents.

7.1.7 District shall have authority to order minor changes in the Work not involving an adjustment in the Contract Sum or an extension of the Contract Time and not inconsistent with the intent of the Contract Documents. Such changes shall be effected by written order, and shall be binding on District and Contractor. Contractor shall carry out such written orders promptly.

## **7.2 CHANGE ORDERS AND CHANGE ORDER REQUESTS**

7.2.1 Contractor may request adjustments to the Contract Sum or Contract Time if, and only if, Contractor follows the procedures specified in the Contract Documents, including, without limitation, the procedures set forth in this Article 7.2. If requested by District or Construction Manager, or if Contractor believes that it is entitled to an adjustment of the Contract Sum or Contract Time due to Extra Work, Contractor shall submit to District and the Construction Manager a Change Order Request in writing within seven (7) Days after the occurrence of the circumstances giving rise thereto setting forth the circumstances that are the basis of the Change and Contractor's estimate of the additional Allowable Costs associated with the Extra Work in the form required by the General Conditions, Special Provisions and Technical Specifications and Contractor's proposed adjustments of the Contract Sum and the Contract Time, if any, for performing the Extra Work. If Contractor's Change Order Request includes a request for adjustment to the Contract Time, it shall include such information as required by the General Conditions and/or Special Provisions and Technical Specifications, including but not limited to a "Fragnet" or "time impact analysis," which identifies all critical and non-critical activities affected by the Change Order Request and showing logic ties into all existing affected activities noted on the latest approved, updated Construction Schedule.

7.2.2 In the event that the parties are unable to agree as to the reasonable cost and time to perform a Change to the Work based upon Contractor's Change Order Request and District does not elect to have the Change in the Work performed on a time and material basis, District may, in its discretion, either order performance of the Work by Field Order or make a unilateral determination of the reasonable additions or savings in cost and time attributable to the Change in the Work, based upon District's estimate, Contractor's submission or a combination thereof. A Change Order shall be issued for the amounts of cost and time determined by District and shall be promptly performed by Contractor. District's unilateral determination shall become binding upon Contractor unless Contractor submits a Contractor Claim in writing to District within twenty-one (21) Days of the issuance of the Change Order. No dispute, disagreement, nor failure of the parties to reach agreement regarding the amount, if any, of any adjustment to the Contract Sum or Contract Time due to a Change in the Work, shall relieve Contractor from the obligation to proceed with performance of the Work, including, without limitation, performance of the Change, promptly and expeditiously.

(v) General Conditions

7.2.3 Changes involving Extra Work that District elects to have performed on a time and material basis shall be performed, whether by Contractor's forces or the forces of Subcontractors or Sub-Subcontractors, based on actual Allowable Costs in performing the Change in the Work and with mark-ups in accordance with Section 7.3 of the Contract. Contractor shall submit on a daily basis to the Construction Manager daily time and material tickets to include the identification number assigned to the Change; the location and description of the Change; the classification of labor employed (and names and social security numbers if requested); the materials used; the equipment rented (not tools); and such other evidence of cost as the Construction Manager may require. The Construction Manager may require authentication of all time and material tickets and invoices by persons designated by the Construction Manager for such purpose. The failure of Contractor to secure any required authentication shall, if District elects to treat it as such, constitute a waiver by Contractor of any right to adjustment of the Contract Sum for the cost of all or that portion of the Extra Work covered by a non-authenticated ticket or invoice. The adjustment to the Contract Sum for the Extra Work will be based on the accumulation of Allowable Costs as provided in Article 7.2.5 below. It is Contractor's responsibility to review the Change Order Request invoicing of Contractor and Subcontractors and Sub-subcontractors for accuracy of Subcontractor Markups as defined in Section 7.3 (Compensation to Contractor) of the Construction Contract.

7.2.4 Adjustments to the Contract Sum for Changes for which Contractor is entitled to an adjustment of the Contract Sum by Change Order shall be computed at District's sole election on the basis of one or more of the following:

- (i) Unit prices stated in the Contract Documents or agreed upon by District and Contractor, which unit prices shall be deemed to include Contractor Markup and Subcontractor/Sub-subcontractor Markups permitted by Section 7.3 (Compensation for Extra or Deleted Work) of the Construction Contract.
- (ii) A lump sum agreed upon by District and Contractor, based on the estimated Allowable Costs and Contractor Markup and Subcontractor/Sub-Subcontractor Markup computed in accordance with Section 7.3 (Compensation for Extra or Deleted Work) of the Construction Contract.
- (iii) Contractor's Allowable Costs, plus Contractor Markup and Subcontractor/Sub- subcontractor Markups applicable to such Extra Work computed in accordance with Section 7.3 (Compensation for Extra or Deleted Work) of the Construction Contract.

7.2.5 Allowable Costs shall mean only those costs listed in, and substantiated and documented in accordance with, this provision and that are not disallowed pursuant to Articles 7.2.6, 7.2.11 or other provisions of the Contract Documents. Allowable Costs are the actual costs necessarily incurred by Contractor and all

(v) General Conditions

Subcontractors and Sub- subcontractors, of every Tier, that actually perform the Extra Work caused by the Change(s) and that are incurred in the direct performance of the Extra Work or that are saved by reason of Deleted Work, and are strictly limited to the following:

.1 Labor. The actual straight-time (and the premium time portion of overtime, if approved in writing in advance by District or the Construction Manager) wages or salaries for employees employed at the Site, or at fabrication sites off the Site, plus employer payments collectively referred to as "Fringe Benefits and Payroll Taxes," of payroll, taxes and insurance, health and welfare pension, vacation, apprenticeship funds, and other direct costs resulting from Federal, State or local laws, as well as assessments or benefits required by lawful collective bargaining agreements. The use of a labor classification, which would increase the Allowable Costs will not be permitted unless Contractor establishes the necessity for such additional costs. Labor costs for equipment operators and helpers shall be payable under this provision only when such costs are not included in the invoice for equipment rental.

.2 Material. The cost of materials and consumable items which are furnished and incorporated into the Work at invoice or lowest current price at which such materials are locally available and delivered to the Site in the quantities involved, plus sales tax, freight and delivery. District reserves the right to approve materials and sources of supply, or to supply materials to Contractor, if necessary, for the Work. No markup shall be applied to any material provided by District. Material re-stocking charges shall be limited to 5% of the amount of material. All discounts, rebates and refunds from the sale of surplus materials and consumable items shall accrue to District, and Contractor shall make provision so that they may be obtained.

.3 Tool and Equipment Rental. Rental charges for necessary machinery and equipment, whether owned or hired, as authorized in writing by District or the Construction Manager, exclusive of hand tools. No payment will be made for the use of tools that have a replacement value of \$500 or less. When the equipment is owned by Contractor, the rental rate shall be as listed for such equipment in the California Department of Transportation publication entitled "Labor Surcharge and Equipment Rental Rates," which is in effect on the date the Work is accomplished. When equipment is not listed in said publication, the rate to be paid shall be as herein defined, or a suitable rental rate for such equipment will be established by the Construction Manager. Regardless of ownership, the rates to be used in determining equipment rental cost shall not exceed listed rates prevailing locally at equipment rental agencies or distributors at the time the work is performed. The rental rates paid shall include the cost of fuel, oil, lubrication, supplies, small tools, necessary attachments, repairs and maintenance of any kind, depreciation, storage, insurance and all incidentals. If equipment is used intermittently, when not in use it shall be returned to its rental source unless Contractor elects to keep it at the Site at no expense to District.



The reported rental time for equipment already at the Site shall be the duration of its use on the Extra Work, commencing at the time it is first put into actual operation on the Extra Work, plus the time required to move it from its previous site and back, or to a closer site.

.4 Royalties and Permits. Costs of royalties and permits solely related to the Extra or Deleted Work.

.5 Insurance and Bonds. Additional costs of insurance and bonds, not to exceed two percent (2%) of the total of Parts .1 through .4, above.

7.2.6 Extra Work Costs shall not include any of the following, which are construed to be included in Contractor's Markup:

- (i) Superintendent(s).
- (ii) Assistant Superintendent(s).
- (iii) Project Engineer(s).
- (iv) Project Manager(s).
- (v) Scheduler(s).
- (vi) Estimator(s).
- (vii) Drafting or detailing.
- (viii) Small tools (with a replacement value under \$500).
- (ix) Home or field office expenses, including staff, materials, and supplies.
- (x) Trailer or storage rental and expense, whether on the Site or off the Site.
- (xi) Data processing personnel and equipment.
- (xii) Site fencing.
- (xiii) Utilities, including, without limitation, gas, electric, sewer, water, telephones.
- (xiv) Telephone, facsimile, e-mail and copier.
- (xv) Overhead, administrative, or general expenses of any kind.
- (xvi) Loss of efficiency or productivity, or other impact cost due to the effect of the Extra Work on the performance of other Work or the Work of other trades

(v) General Conditions

on the Project.

(xvii) Capital expenses, including interest on capital employed in connection with Extra Work.

(xviii) Legal costs.

(xix) Federal, State, or local income and franchise taxes.

(xx) Profit.

(xxi) Any Extra Work Costs incurred more than twenty (20) Days prior to submission by Contractor of its Change Order Request pursuant to Article 7.2.1.

(xxii) Cost of any item not specifically and expressly included in the items described in Article 7.2.5.

7.2.7 The term "Contractor Markup" shall mean the full amount of compensation for all costs and expenses including overhead and profit not included in the Allowable Costs, whether or not referred to in Article 7.2.5. Contractor Markup shall be computed as provided in Section 7.3 (Compensation for Extra or Deleted Work) of the Construction Contract.

(i) For Work to be omitted by Change Order, the reduction of the Contract Sum shall be computed on the basis of one or more of the following: Unit prices stated in the Contract Documents or agreed upon by District and Contractor.

(ii) A lump sum agreed upon by District and Contractor, based upon the estimated Allowable Costs that would have been incurred in performing the Deleted Work, plus Contractor Markup provided for in the Construction Contract.

(iii) A sum unilaterally determined by District, if District and Contractor cannot agree upon one or both of the methods described in paragraphs (i) or (ii), above.

7.2.8 No Contractor Claim for adjustment of the Contract Sum shall be allowed if asserted after final payment under the Construction Contract.

7.2.9 If anyone Change involves both Extra Work and Deleted Work in the same portion of the Work, the Contractor Markup to be added or credited will be based on the net difference between amount allowed for the Extra Work and Deleted Work.

7.2.10 The Contract Sum will be adjusted for Delay only if and to the extent allowed by the Contract for Compensable Delay. Contractor agrees to accept such adjustments in its compensation as its sole and exclusive remedy and

(v) General Conditions

recovery for Delay, disruption, hindrance, interference, loss of productivity, labor or material cost escalations, inefficiency, acceleration, impact costs associated with the effect of the Changes on the Work, extended or extraordinary overhead (direct or indirect) or other Losses or damages due to Delay, of any kind.

7.2.11 District has the right to increase or decrease the quantity of any unit price item for which an estimated quantity is stated in the Bid Documents.

7.2.12 The signing of a Change Order indicates that the parties have reached a full resolution, settlement and accord and satisfaction with respect to all Contractor Claims for cost and extensions of time that were asserted, or that could have been asserted, in connection with the Change, whether known or unknown at the time of execution of the Change Order, and that are related to the subject matter of the Change Order, including, without limitation, all Contractor Claims, costs or damages for Delay, disruption, hindrance, interference, extended or extraordinary direct and indirect overhead, multiplicity of Changes, loss of productivity, labor or material cost escalations, inefficiency, the impact of the Change on the Work, legal expenses, consultant costs, interest, lost profits or revenue, bond or insurance costs, currency fluctuations, changes in taxes or other related Claims, costs or damages. Change Orders shall be executed by Contractor without any express reservation of rights by Contractor to reserve for the future the right to assert or recover from District any such Claims, costs or damages.

7.2.13 Contractor's cost breakdowns submitted with its Change Order Requests (including, without limitation, requests for cost reimbursement for Delay, disruption, hindrance and interference associated with extras, Changes, additions or deletions) shall be itemized in a manner that, with mathematical certainty and without reliance upon probabilities or inferences, segregates the direct, actual reimbursable costs associated with each individual extra, Change, addition, deletion and (on an event-by-event basis) each individual Delay or disruption event. Change Order Requests shall not be based, in whole or in part, upon any methodology (such as total cost or modified total cost methodologies) that purports to calculate Contractor's additional costs of performance of the extra, Change, addition or deletion (including, without limitation, the additional costs of Delay, disruption or other impact) based on the difference between Contractor's total actual Project or line item costs and its original bid estimate for the Project or any original bid estimate line item. In connection with the foregoing, Contractor represents and warrants that it has the ability to generate and maintain complete and accurate cost accounting records that will reflect:

(i) The actual Allowable Costs incurred or saved for each individual item of Extra Work or Deleted Work; and

(ii) On an event-by-event basis, the effect of each Delay that forms the basis of each request for extension of time, regardless of their scope, number,

(v) General Conditions

complexity, cumulative effect or time of issuance or occurrence.

7.2.14 As a further condition of Contractor's right to an adjustment of the Contract Sum for Extra Work, Contractor must keep daily, detailed and accurate records itemizing each element of Extra Work Cost and shall provide substantiating records and documentation, including time cards, invoices and delivery tickets listing all labor, materials, and equipment involved for that day. Failure to submit such records daily shall waive any rights for recovery of Allowable Costs for that day. Such records and documentation shall be submitted to and Approved by Construction Manager on a daily basis.

### **7.3 FIELD ORDERS**

7.3.1 Upon receipt of a Field Order, Contractor shall, within a reasonable time, proceed with the Work described in the Field Order. If the Field Order involves Extra Work and sets forth a determination for adjustment of the Contract Sum or Contract Time with which Contractor disagrees, Contractor shall advise District of its agreement or disagreement in writing within seven (7) Days of such receipt. Failure by Contractor to provide such written notice shall result in its waiving any right to adjustment of the Contract Sum or Contract Time on account thereof.

### **7.4 DISPUTES REGARDING CHANGES**

7.4.1 Provided that District pays to Contractor all undisputed sums due under the Contract Documents for Work performed under Change Orders, Contractor shall not delay, slow, interrupt, or suspend the performance of any Work or any Change because of a dispute between the parties with respect to an adjustment in the Contract Sum or Contract Time.

---

## **ARTICLE 8 – CONTRACT TIME**

### **8.1 COMMENCEMENT OF THE WORK**

8.1.1 Commencement of the Work shall begin on the date specified in the Notice to Proceed.

### **8.2 PROGRESS AND COMPLETION**

8.2.1 By signing the Contract, Contractor represents to District that the Contract Time is reasonable for performing the Work and that Contractor is able to perform the Work within the Contract Time.

.1 The Construction Schedule may reflect a period of performance that is shorter than the Contract Time; provided however, that the difference shall be deemed as float and nothing in this provision or in any other provision of the Contract Documents shall be construed as creating any contractual right, express or implied, on the part of Contractor to finish the Project earlier than the Contract Time and under no circumstances shall District be liable to Contractor for any costs, damages or compensation due to the inability of Contractor to complete the Work earlier than the Contract Time, regardless of the cause, including, without limitation, acts or omissions (intentional or negligent) of District.

.2 Contractor has included in its Bid price the costs of all Contractor and Subcontractor overhead (direct and indirect) and Special Provisions and Technical Specifications, including but not limited to all Project staff, temporary facilities, temporary utilities, and home office overhead for the entire duration of the Contract Time. The above costs must be included in Contractor's Bid notwithstanding Contractor's anticipation of completion in fewer days than established by the Contract Time.

.3 No increase in the Contract Sum shall be made or granted for Compensable Delay if, for any reason including but not limited to Delay caused by District, Contractor completes the Work before expiration of the Contract Time.

.4 No reduction in the Contract Sum shall be made nor will Contractor be required to remain on the Project Site if the Work is completed before expiration of the Contract Time.

.5 The Construction Manager will schedule and hold weekly progress meetings and other meetings as determined by the Construction Manager. Contractor and/or Contractor's designee shall be present at each meeting. Contractor may also be required to request attendance by representatives of its suppliers, manufacturers and Subcontractors.

8.2.2 Except by agreement or instruction of District in writing, Contractor shall not commence operations on the Site or elsewhere prior to the effective date of

insurance required by Article 11 to be furnished by Contractor. Contractor's obligations to commence the Work and to complete the Work within the Contract Time shall not be changed by the effective date of such insurance.

8.2.3 Contractor shall proceed expeditiously with adequate forces and shall achieve Substantial Completion within the Contract Time. If District determines and notifies Contractor that Contractor's progress is such that Contractor will not complete the Work within the Contract Time, Contractor shall, immediately and at no additional cost to District, take all measures necessary, including working such overtime and additional shifts (other than District's normal working hours of 7:00 AM to 6:00 PM, Monday through Friday and 9:00 AM to 5:00 PM on Saturday), to ensure that the Work is Substantially Completed within the Contract Time. Upon receipt of such notice from District, Contractor shall immediately respond in writing setting forth a detailed plan for accelerating the Work in a manner acceptable to District. Contractor shall not be entitled to any reimbursement or payment of costs, expenses or damages incurred as a result of an acceleration of the Work that is performed pursuant to this provision. District may also take all necessary measures to ensure no further Delays to the Substantial Completion of the Work within the Contract Time. Contractor shall reimburse District, or District may withhold from payment due to Contractor, sums expended by District to perform such measures.

8.2.4. During unfavorable weather, wet ground or other unsuitable construction conditions, Contractor shall confine the operations to Work that will not be affected adversely by such conditions. No portion of the Work shall be constructed under conditions which would affect adversely the quality thereof or be detrimental to the quality of water discharges, unless special means or precautions are taken by Contractor to perform the Work in a proper and satisfactory manner.

### **8.3 DELAY**

8.3.1 Contractor may make a Contractor Claim for an extension of the Contract Time, for an Excusable Delay or a Compensable Delay, subject to the following:

.1 In order to avoid double counting concurrent Delays, if an Excusable Delay and a Compensable Delay occur concurrently, the maximum extension of the Contract Time shall be the number of days from the commencement of the first Delay to the cessation of the Delay which ends last.

.2 If an Unexcused Delay occurs concurrently with either an Excusable Delay or a Compensable Delay, the maximum extension of the Contract Time shall be the number of Days, if any, by which the Excusable Delay or the Compensable Delay exceeds the Unexcused Delay.

.3 If an Unexcused Delay occurs concurrently with both an Excusable Delay and a Compensable Delay, the maximum extension of the Contract Time shall

be the number of Days, if any, by which the number of Days determined pursuant to Article 8.3.1.2 exceeds the number of Days of the Unexcused Delay.

8.3.2 As a condition precedent to Contractor's right to an extension of Time adjusting the Contract Time and the Contract Sum for Compensable Delay, it must provide written notice to District within seven (7) Days of the date that Contractor learned of the Delay or should have learned of the Delay in exercise of diligence and reasonable care, setting forth:

- (i) A description of the Delay;
- (ii) A statement that the Delay is critical to completion; and
- (iii) The probable effect of the Delay in terms of the number of Days' extension Contractor believes are required to the Contract Time.

It is agreed that the form, content and timeliness of the written notice required by Article 8.3.2 is of the essence to District's ability to adequately monitor the progress of the Work, to differentiate between critical and non-critical Delays, and to prioritize its actions in a manner that is appropriately targeted to mitigate the effect of delays. Accordingly, Contractor agrees that failure to provide written notice in the manner required by Article 8.3.2 shall be conclusively deemed a waiver of the right to an adjustment of the Contract Sum and Contract Time on account thereby, regardless of whether the circumstances of the Delay may have been known or suspected by District or the Construction Manager and that no other form of notice (including, without limitation, meeting minutes, log entries or schedule updates) shall suffice as constituting notice to District in accordance with Article 8.3.2.

8.3.3 For a Compensable Delay, Contractor shall be entitled to an adjustment in the Contract Sum in a daily amount equal to Contractor's per diem amount as stated in the Contract multiplied by the number of Days of extension for Compensable Delay, if any, permitted under the Contract Documents. Such per diem amount shall be Contractor's sole and exclusive right and compensation to cover all costs and damages to Contractor and to its Subcontractors and Sub-subcontractors, of every Tier, for Compensable Delays and all other Claims for costs, acceleration, expenses, Losses, damage or compensation, of any kind, for additional supervision, administration, extended or extraordinary overhead (direct or home office), additional insurance or bond costs, loss of productivity, inefficiency, labor, wage, material or equipment escalation, or other costs, expenses or damages due to Delay, interruption, hindrance, compression, disruption, or the impact or ripple effect of Delays on the Work, are conclusively waived.

8.3.4 The parties agree that District's exercise of its rights to order Changes, whether or not resulting in Extra Work, regardless of the extent and number of

Changes, or to suspend the Work, is within the contemplation of the parties.

8.3.5 The determination of whether a Delay is an Excusable Delay, Compensable Delay or Unexcused Delay shall not be affected by the fact that any earlier Delay occurred, regardless of fault or causation.

8.3.6 All time limits stated in the Contract Documents are of the essence.

---



## **ARTICLE 9 – PAYMENTS AND COMPLETION**

### **9.1 SCHEDULE OF VALUES**

9.1.1 Within thirty (30) Days after signing the Contract, but in any event a maximum of ten (10) Days of receipt of the Notice to Proceed, Contractor shall submit to District through the Construction Manager a Schedule of Values reflecting cost breakdown of the Contract Sum in a form approved by the Construction Manager. The Schedule of Values shall itemize as separate line items the cost of each scheduled Work activity and all other costs, including warranties, Record Documents, insurance, bonds, overhead and profit, the total of which shall equal the Contract Sum and shall be made out in a form approved by the Construction Manager. The Schedule of Values, when approved by District, shall become the basis for determining the cost of Work requested on Contractor's Applications For Payment. Contractor shall submit a statement based upon this breakdown, and if required, itemized in such form and supported by such evidence as the Construction Manager may direct, showing Contractor's right to the payment claimed.

### **9.2 PROGRESS PAYMENT**

9.2.1 Subject to District's right of withholding under Article 9.4.2, District agrees to pay to Contractor within thirty (30) Days of receipt of an undisputed and properly submitted Application for Payment an amount equal to ninety-five percent (95%) of the sum of the following:

- (i) Construction Manager's determination of the value, expressed as a percentage of the Contract Sum, of the Work in permanent place that has been tested as of the end of the preceding month.
- (ii) Plus Construction Manager's determination of the value of materials suitably stored but not yet incorporated into the Work, subject to Article 9.3.6.
- (iii) Less amounts previously paid.

9.2.2 At any Time after 50% of the Work has been determined by District to be completed, if District determines in its sole discretion that satisfactory progress on the Work is being made, District may, in its sole discretion, make any of the remaining progress payments in accordance with the calculation in Article 9.2.1 based on 100% of District's determination of the value of the Work in place and of stored materials not incorporated.

9.2.3 Progress payments shall not be construed as District's Acceptance of any or all of the Work and shall not be a waiver of any or all rights District has under the Contract Documents.



### 9.3 APPLICATION FOR PAYMENT

9.3.1 At the end of each month, Contractor shall submit to District an itemized Application For Payment, requesting payment for Work as of the end of that month that is calculated in accordance with the formula for payment set forth in Article 9.2.1. The Application For Payment shall be prepared:

- (i) Utilizing the format as designated by District or the Construction Manager.
- (ii) Itemized in accordance with the Schedule of Values.
- (iii) Including such data substantiating Contractor's right to payment as District may reasonably require, such as invoices, certified payrolls, daily time and material records, and, if securities are deposited in lieu of retention pursuant to Article 9.5, a certification of the market value of all such securities as of a date not earlier than five (5) Days prior to the date of the Application For Payment.
- (iv) Showing itemized amounts for Change Orders, Modifications and retention.

9.3.2 Applications For Payment shall not include requests for payment on account of Changes which have not been authorized by Change Orders or amounts Contractor does not intend to pay a Subcontractor because of a dispute or other reason.

9.3.3 If required by District, an Application For Payment shall be accompanied by all of the following:

- (i) A summary showing payments that will be made to Subcontractors covered by such application.
- (ii) Conditional waivers and releases of claims and stop notices from Contractor and each Subcontractor and Sub-subcontractor, of every Tier, listed in the current Application For Payment covering sums requested in the current Application For Payment.
- (iii) Unconditional waivers and releases of claims and stop notices, from Contractor and each Subcontractor and Sub-subcontractor, of every Tier, listed in the preceding Application For Payment covering sums disbursed pursuant to that preceding Application For Payment.

9.3.4 Contractor warrants that, upon submittal of an Application For Payment, all Work for which Certificates For Payment have been previously issued and payment has been received from District, shall be free and clear of all claims, stop notices, security interests and encumbrances in favor of Contractor, Subcontractors, Sub-subcontractors, of every Tier, or other persons or firms entitled to make claims by reason of having provided labor, materials or equipment relating to the Work.

- (v) General Conditions

9.3.5 The making of final payment shall constitute a waiver of all Claims by District except those arising from unsettled liens, faulty or Defective Work, failure of the Work to comply with the requirements of the Contract Documents or terms of any special guarantees required by the Contract Documents.

9.3.6 At the sole discretion of District, the Construction Manager may approve for inclusion in Contractor's Application For Payment the cost of materials to be incorporated in the Work but not yet incorporated in the Work and already delivered and suitably stored either at the Site or at some other appropriate location acceptable to District. In such case, Contractor shall furnish evidence satisfactory to District:

- (i) Of the cost of such materials.
- (ii) That such materials are under the exclusive control of Contractor, or if not, that title to the materials is in District, free of any lien or encumbrance and that the materials are safely and suitably stored in a bonded warehouse with appropriate insurance coverage satisfactory to District to cover any Loss.

Any payment pursuant to this provision shall not be construed as an inspection or acceptance of the materials nor shall it relieve Contractor of its continuing and sole responsibility for the care and protection of such materials nor shall it relieve Contractor from sole responsibility for any loss or damage to the materials from any cause whatsoever nor act as a waiver of the right of District to require strict fulfillment by Contractor with all terms of the Contract Documents.

9.3.7 District shall have the right, in its sole discretion, to make payments of monies owing to Contractor by means of direct payment to Subcontractors or Sub-subcontractors, of any Tier of any unpaid work performed by any Subcontractor or Sub-subcontractor of any Tier, or by joint payment to Contractor and to Subcontractors or Sub-subcontractors, of any Tier. The making of such payments shall not be construed as the assumption of any obligation on the part of District or as creating any contractual relationship between District and any Subcontractor or Sub-subcontractor and shall not relieve Contractor of any of its obligations under the Contract Documents.

## **9.4 CERTIFICATE FOR PAYMENT**

9.4.1 If Contractor has made an Application For Payment in accordance with Article 9.3, the Construction Manager will, not later than seven (7) Days after the date of receipt of an Application For Payment prepared and submitted in accordance with the Contract Documents, issue to District, with copy to Contractor, a Certificate For Payment in such amount as the Construction Manager determines is due.

If Construction Manager determines that Contractor's Application For Payment

has not been properly prepared or submitted, then Construction Manager, within the seven (7) Day period provided for in Article 9.4.1, notify Contractor in writing of the reasons why the Application for Payment is being rejected.

9.4.2 Approval of all or any part of an Application For Payment may be withheld, a Certificate For Payment may be withheld or all or part of a previous Certificate For Payment may be nullified and that amount withheld from a current Certificate For Payment in order to protect District against actual or threatened loss as a result of any of the following:

- (i) Defective Work not remedied.
- (ii) Third-party claims against Contractor or District arising from the acts or omissions of Contractor, Subcontractors, or Sub-subcontractor, of any Tier.
- (iii) Stop notices.
- (iv) Failure of Contractor to make timely payments due Subcontractors for material or labor.
- (v) A reasonable doubt that the Work can be completed for the balance of the Contract Sum then unpaid.
- (vi) Damage to District or Separate Contractor for which Contractor is responsible.
- (vii) Reasonable evidence that the Work will not be completed within the Contract Time.
- (viii) Failure of Contractor to maintain and update As-Built or Record Documents.
- (ix) Failure of Contractor to submit schedules, reports, or their updates as required by the Contract Documents.
- (x) Performance of Work by Contractor without approved Submittals.
- (xi) Liquidated or actual damages assessed in accordance with the Construction Contract.
- (xii) Any other failure of Contractor to perform an obligation under the Contract Documents.

9.4.3 Subject to the withholding provisions of Article 9.4.2 and when any or all of the noted deficiencies or others have been removed, District shall pay Contractor the amount set forth in the Certificate For Payment in accordance

(v) General Conditions

with its normal disbursement procedures.

9.4.4 Neither District nor the Construction Manager shall have an obligation to pay or to see to the payment of money to a Subcontractor or Sub-subcontractors, of any Tier, except as may otherwise be required by Law.

9.4.5 Neither a Certificate For Payment nor any payment (progress or final) shall be construed as a waiver of any rights arising from Defective Work.

## **9.5 DEPOSIT OF SECURITIES IN LIEU OF RETENTION AND DEPOSIT OF RETENTION INTO ESCROW**

9.5.1 At the request and expense of Contractor, a substitution of securities may be made as found in the California Government Code, Section 16430, and as authorized by the California Public Contract Code, Section 22300, in lieu of monies retained by District under Article 9.2 to ensure performance under the Contract Documents. Securities equivalent in value to the retention amount required by the Contract Documents for each Certificate For Payment shall be deposited by Contractor with a state or federally chartered bank in the State of California ("Escrow Agent"), which shall hold such securities pursuant to the escrow agreement referred to in Article 9.5.3 until final payment is due in accordance with Article 9.8. Securities shall be valued as often as conditions of the securities market warrant, but in no case less than once per month. Contractor shall deposit additional securities so that the current market value of the total of all deposited securities shall be at least equal to the total required amount of retention.

9.5.2 Alternatively to Article 9.5.1, and at the request and expense of Contractor, District shall deposit retention directly with the Escrow Agent. Contractor may direct the investment of such deposited retention into interest bearing accounts or securities, and such deposits or securities shall be held by the Escrow Agent upon the same terms provided for securities deposited by Contractor.

9.5.3 A prerequisite to the substitution of securities in lieu of retention or the deposit of retention into escrow shall be the execution by Contractor, District, and the Escrow Agent of an Escrow Contract for Deposit of Securities in Lieu of Retention and Deposit of Retention forms provided by District. The terms of such escrow agreement are incorporated into the requirements of Article 9.5.

9.5.4 Release of funds or securities from escrow shall be made with Contractor's final payment.

## **9.6 BENEFICIAL OCCUPANCY / BENEFICIAL USE**

9.6.1 District reserves the right, at its option and convenience, to occupy or

otherwise make use of all or any part of the Work, at any time prior to issuing the Certificate of Substantial Completion, upon thirty (30) Days' notice to Contractor. Such occupancy or use is herein referred to as "Beneficial Occupancy/Use." Beneficial Occupancy/Use shall be subject to the following conditions:

.1 District, Design Consultant and Construction Manager will make an inspection of the portion of the Work to be beneficially occupied and prepare a list of items to be completed or corrected prior to Substantial Completion.

.2 Beneficial Occupancy/Use by District shall not be construed by Contractor as Acceptance by District of that portion of the Work which is to be occupied. District may, however, at its sole option, relieve Contractor of Contract requirements to protect Work being beneficially occupied by District where such relief is specifically designated by District in writing.

.3 Beneficial Occupancy/Use by District shall not constitute a waiver of existing Claims of District or Contractor against each other.

.4 Contractor shall provide, in the areas beneficially occupied and on a continual basis (if required), utility services, heating, and cooling for systems which are in operable condition at the time of Beneficial Occupancy/Use. All responsibility for the operation and maintenance of equipment shall remain with Contractor while the equipment is so operated. Contractor shall submit to District an itemized list of each piece of equipment so operated with the date operation commences.

.5 The Guarantee to Repair Periods, as defined in Article 12.2, will commence upon the first dates of actual occupancy or use of portions of the Work actually occupied and equipment or systems fully utilized.

.6 District shall pay all normal operating and maintenance costs resulting from its use of equipment in areas beneficially occupied.

.7 District shall pay all utility costs which arise out of the Beneficial Occupancy/Use.

.8 Contractor shall not be responsible for providing security in areas beneficially occupied or used.

.9 District shall use its best efforts to prevent its Beneficial Occupancy/Use from interfering with the conduct of Contractor's remaining Work.

.10 Contractor shall not be required to repair damage caused by District in its Beneficial Occupancy/Use.

.11 Except as provided in Article 9.6, there shall be no added cost to District due to Beneficial Occupancy/Use.

.12 Contractor shall continue to maintain all insurance required by the Contract in full force and effect.

## **9.7 SUBSTANTIAL COMPLETION**

9.7.1 When Contractor gives notice to District that the Work, or portion thereof designated by District for separate delivery, is Substantially Complete, unless District determines that the Work or designated portion thereof is not sufficiently complete to warrant an inspection to determine Substantial Completion, District will inspect the Work, or such designated portion thereof, and prepare and give to Contractor a comprehensive list of items, if any, to be completed or corrected before establishing Substantial Completion. Contractor shall promptly proceed to complete and correct items on the list. Failure to include an item on such list does not alter the responsibility of Contractor to complete all Work in accordance with the Contract Documents. District will then make a further inspection to determine whether the Work or such designated portion thereof is Substantially Complete. If District's inspection discloses any item, whether or not included on the list, which must be completed or corrected before Substantial Completion, Contractor shall, before issuance of the Certificate of Substantial Completion, complete or correct such item. Contractor shall then submit a request for another inspection by District to determine Substantial Completion.

9.7.2 When District determines that the Work or such designated portion thereof is Substantially Complete, District will prepare a Certificate of Substantial Completion on District's form, which when signed by District shall establish the date of Substantial Completion and the responsibilities of District and Contractor for security, maintenance, heat, utilities, insurance, completion of minor items and correction or repair of the Work or such designated portion thereof. Unless otherwise provided in the Certificate of Substantial Completion, the Guarantee To Repair Period for the Work (which is defined in Article 12.2.1), or such designated portion thereof covered by the Certificate of Substantial Completion, excluding any systems provided by Separate Contractors which are not yet fully operational or accepted by District, shall commence on the date of Substantial Completion of the Work or such designated portion thereof. The Guarantee To Repair Period for systems which become fully operational or Accepted subsequent to Substantial Completion will begin on the later of the date they are operational or Acceptance of the Project by District.

## **9.8 FINAL COMPLETION AND FINAL PAYMENT**

9.8.1 Upon receipt of notice from Contractor that the Work is ready for final inspection, District will make such inspection. District will file a notice of completion within ten (10) Days after Acceptance by District. After receipt of the Final Application for Payment, if District determines that Final Completion is achieved, District will issue a Certificate for final payment.



9.8.2 Without limitation to any other provisions of the Contract Documents, before final payment for Work under this Construction Contract is authorized, the Work has been completed in accordance with the Contract Documents and all applicable standards of care and the following requirements of the Contract Documents must be fulfilled by Contractor:

- (i) The submittal of an Application for Final Payment, together with supporting documentation, as required by Article 9.3.
- (ii) Completion and delivery by Contractor to District of all required written guarantees, warranties, operation and maintenance manuals, As-Built Documents and other Record Documents and such other documents as required by the Contract Documents.
- (iii) Delivery by Contractor to District of an affidavit, signed under penalty of perjury, stating that all workers and persons employed, all firms supplying the materials, and all Subcontractors and Sub-subcontractors, of every Tier, have been paid in full; and that there are no bills outstanding against the Work for either labor or materials, except certain items, to be set forth in such affidavit covering disputed claims or items in connection with which notices to withhold have been filed under the provisions of the statutes of the State of California.
- (iv) Completion of all construction work in a manner acceptable to District.
- (v) Submission of conditional releases of claims and stop notices upon final payment from Contractor and its Subcontractors and Sub-subcontractors, of every Tier, with no reservation of rights for disputed claims or amounts. Contractor shall pay or cause to be paid to Subcontractors and Sub-Subcontractors, of every Tier, the amount stated in the conditional releases within five (5) Days after receipt of the final payment, and shall promptly thereafter furnish evidence of such payment to District.

9.8.3 Acceptance of final payment by Contractor shall constitute a waiver of all Claims, except those previously made in writing and identified by Contractor as unsettled at the time of the Application for Final Payment.

9.8.4 District shall have the right, in its sole discretion, to make payment of amounts retained from progress payments on the Work of any Subcontractor at any time prior to Final Completion. The making of such early payment of retention shall not be construed as creating any obligation on the part of District nor shall it relieve Contractor of any of its obligations under the Contract Documents.

## **ARTICLE 10 – PROTECTION OF PERSONS AND PROPERTY**

### **10.1 SAFETY PRECAUTIONS AND PROGRAMS**

10.1.1 Contractor shall be solely and completely responsible for initiating, maintaining and supervising all safety precautions and programs on the Site in connection with the performance of the Construction Contract, including safety of all persons for the duration of the Work, on a 24-hour day, 7-day week basis.

10.1.2 Prior to the start of construction, Contractor shall submit to District a copy of Contractor's safety program for the Project. A copy of this program shall be maintained on Site at all times. The safety program shall include, at a minimum:

- (i) Management policy, illness and injury prevention program (as described below).
- (ii) Safety meetings.
- (iii) Accident investigation.
- (iv) Basic accident causes.
- (v) Safety inspection check list.
- (vi) Fire prevention and control.
- (vii) Report forms.
- (viii) Employee safety manual.

10.1.3 Prior to the start of construction, Contractor shall submit to District a copy of an illness and injury prevention program as required by law. This program must be submitted prior to issuance by District of Notice to Proceed. It must include provisions for Contractor reviewing and monitoring all Subcontractor safety programs.

### **10.2 SAFETY OF PERSONS AND PROPERTY**

10.2.1 Precaution shall be exercised at all times for the protection of persons and property. Contractor shall have available at the Site, copies or suitable extracts of "Construction Safety Orders" and "General Industrial Safety Orders" issued by the State Division of Industrial Safety. Contractor shall comply with provisions of these and all other applicable laws, ordinances, and regulations.

10.2.2 Contractor shall immediately respond to notice from District of unsafe conditions, shall take adequate precautions for safety of persons on the Site, and

- (v) General Conditions

shall provide adequate protection to prevent injury or Loss to the following:

- (i) Employees involved in the Work and other persons who may be affected thereby.
- (ii) The Work in place and materials and equipment to be incorporated therein, whether in storage on or off the Site, under care, custody, or control of Contractor, Subcontractors, or Sub-subcontractors.
- (iii) Other property at the Site and adjoining property(ies).

10.2.3 Contractor shall promptly remedy damage and Loss (other than damage or Loss insured under property insurance required by the Contract Documents) to property caused in whole or in part by Contractor or its Subcontractors or Sub-subcontractors, of any Tier, or anyone for whose acts they may be liable and for which Contractor is responsible. An exception is Loss attributable to acts of the Construction Manager, District or Design Consultant or anyone directly or indirectly employed by either of them, or by anyone for whose acts either of them may be liable, and not attributable to the fault or negligence of Contractor or its Subcontractors or Sub-subcontractors, of any Tier.

10.2.4 Contractor shall erect and maintain, as required by existing conditions and performance of the Work, adequate safeguards for safety and protection, including providing adequate lighting and ventilation, posting danger signs and other warnings against hazards, promulgating safety regulations and notifying owners and users of adjacent sites and utilities.

10.2.5 When use or storage of hazardous materials, equipment, or unusual methods are necessary for execution of the Work, Contractor shall exercise the utmost care and carry on such activities only under the supervision of properly qualified personnel.

10.2.6 Contractor shall be required to provide at the Site a member of Contractor's organization, typically the Superintendent, whose responsibility it shall be to provide instruction to persons present on the Site about prevention of accidents and overall jobsite safety. If Contractor has another individual responsible for these activities, Contractor shall notify District in writing.

10.2.7 Contractor shall be responsible for locating, providing, and coordinating the storage and staging of materials and equipment on-Site and off-Site and shall not load/store or permit any part of the Work on the Site to be loaded/stored so as to endanger the safety of persons or property.

10.2.8 Contractor shall protect its materials and the Work from damage in a manner satisfactory to District and shall make good, without charge to District, all damage due to negligence in providing proper protection.

(v) General Conditions

10.2.9 Contractor shall take necessary precautions to guard against and eliminate possible fire hazards and to prevent damage to the Work, building materials, equipment, temporary field offices, storage sheds and public and private property.

10.2.10 Contractor shall not permit the possession or use of alcohol or controlled substances on the Site.

10.2.11 Explosives may be used only when authorized in writing by District. Explosives shall be handled, used and stored in accordance with applicable regulations.

### **10.3 EMERGENCIES**

10.3.1 In an emergency affecting the safety of persons or property, Contractor shall immediately act to prevent or minimize damage, injury or loss. Contractor shall immediately notify the Construction Manager and District, which notice may be oral, followed within twenty-four (24) hours after occurrence of the incident by written confirmation, of the occurrence of such an emergency and Contractor's action.

---

## **ARTICLE 11 – INSURANCE AND BONDS**

### **11.1 CONTRACTOR'S INSURANCE**

11.1.1 Prior to commencing the Work, Contractor shall procure and maintain at Contractor's own cost and expense, insurance as required in the Construction Contract between Contractor and District against claims for injuries to persons or damages to property which may arise out of or result from the performance of the Work by Contractor, its Subcontractors or Sub-subcontractors, by anyone directly or indirectly employed by any of them, or by anyone for whose acts any of them may be liable.

### **11.2 BOND REQUIREMENTS**

11.2.1 Within ten (10) Days after the issuance of the Notice of Award and prior to commencing Work on the Project, Contractor shall file with District good and sufficient Labor and Material Payment and Performance Bonds each in the amount of 100% of the Contract Sum. The bonds shall be signed by both Contractor and Surety and properly notarized on the District's forms or such other forms as required by District. Should any bond required hereunder or any surety on such bond become or be determined by District to be insufficient, it shall be replaced within ten (10) Days by a bond that fully complies with the requirements of Article 11.2. No further payments to Contractor for Work performed shall be made or due until Contractor has fully complied with the requirements of Article 11.2.

11.2.2 The Payment Bond shall remain in effect until Acceptance of the Work and payment of all Claims by Contractor, Subcontractors, or Sub-subcontractors, of any Tier, have been satisfied. The Performance Bond provided by Contractor shall remain in effect for the duration of the period of all warranties required by the Contract Documents and shall assure faithful performance of all Contractor's obligations under the Contract Documents, including, without limitation, all obligations that survive Final Completion or termination, such as, but not limited to. Contractor's warranty and indemnity obligations.

11.2.3 Contractor shall promptly furnish such additional security as may be required by District to protect its interests and those interests of persons or firms supplying labor or materials to the Work.

11.2.4 Surety companies used by Contractor shall be, on the date the Contract is signed by District and at all times while the bonds are in effect, either California Admitted Sureties or listed in the latest published United States Treasury Department list of Companies Holding Certificates of Authority as Acceptable Sureties on Federal Bonds and as Acceptable Reinsuring Companies and either have a current A.M. Best A VIII rating or be an admitted surety that meets the requirements of the California Code of Civil Procedure, Section 995.660.

11.2.5 The premiums for all Bonds are included in the Contract Sum and shall be paid by Contractor.

11.2.6 The bonds shall name District as obligee.

11.2.7 Change Orders, Field Orders, Modifications, Changes in the Work and adjustments in the scope of Work Contract Sum or Contract Time shall in no way release or exonerate Contractor or its sureties from their obligations and notice thereof shall be waived by such sureties.

11.2.8 District and the Construction Manager shall have the right to communicate with Contractor's sureties with respect to matters that are related to Contractor's performance of its obligations under the Contract Documents. Contractor shall be provided with a copy of all such written communications. Such communications shall not create or be interpreted as creating any contractual relationship between District or the Construction Manager and any such surety.

11.2.9 In the event of a significant (15% or more) increase in Contract Sum, replacement bonds totaling the new Construction Contract amount may be required by District.

---

## **ARTICLE 12 – DEFECTIVE WORK**

### **12.1 UNCOVERING OF WORK**

12.1.1 If a portion of the Work is covered contrary to District's request or direction, or contrary to the requirements of the Contract Documents, it must, if required in writing by District, be uncovered for District's observation and be replaced at Contractor's expense without adjustment of the Contract Time or the Contract Sum.

12.1.2 If a portion of the Work has been covered, which is not required by the Contract Documents to be observed or inspected prior to its being covered and which District has not specifically requested to observe prior to its being covered, District may request to see such Work and it shall be uncovered and replaced by Contractor. If such Work is in accordance with the Contract Documents, the costs of uncovering and replacing the Work shall be added to the Contract Sum by Change Order; and if the uncovering and replacing of the Work extends the Contract Time, an appropriate adjustment of the Contract Time shall be made by Change Order. If such Work is not in accordance with the Contract Documents, Contractor shall pay such costs and shall not be entitled to an adjustment of the Contract Time or the Contract Sum.

### **12.2 CORRECTION OF DEFECTIVE WORK AND GUARANTEE TO REPAIR PERIOD**

12.2.1 Besides guarantees required elsewhere, Contractor shall guarantee in writing all Work for a period of one (1) year. This guarantee termed "Guarantee To Repair Period," is a period of one (1) year, unless a longer period of time is specified in the Special Provisions and Technical Specifications, commencing as follows:

- (i) For any Work not described as incomplete in the Certificate of Substantial Completion, on the date of Substantial Completion.
- (ii) For space beneficially occupied or for separate systems fully utilized prior to Substantial Completion pursuant to Article 9.6, from the first date of such Beneficial Occupancy or actual use, as established an appropriate written authorization for Beneficial Occupancy.
- (iii) For all Work other than (i) or (ii) above, from the date of filing of notice of completion pursuant to Article 9.8.

12.2.2 Contractor shall (i) correct Defective Work that becomes apparent during the progress of the Work or during the Guarantee To Repair Period and (ii) replace, repair, or restore to District's satisfaction any other parts of the Work and any other real or personal property which is damaged or destroyed as a result of Defective Work or the correction of Defective Work, without any expense

(v) General Conditions

whatsoever to District. District will give notice of observed Defective Work with reasonable promptness, and Contractor shall promptly commence such correction, replacement, repair or restoration upon notice from District, but in no case later than seven (7) Days after receipt of such notice. Contractor shall diligently and continuously prosecute such correction to completion. Contractor shall bear all costs of such correction, replacement, repair, or restoration and all Losses resulting from such Defective Work, including additional testing, inspection and compensation for District's or District's services and expenses. Contractor shall perform corrective Work at such times that are acceptable to District and in such a manner as to avoid, to the extent practicable, disruption to District's activities. Ordinary wear and tear, unusual abuse or neglect are excepted from this guarantee. Contractor shall notify District upon completion of repairs.

12.2.3 If immediate correction of Defective Work is required for life safety or the protection of property or, if in the opinion of District, Defective Work creates a dangerous condition or requires immediate corrections or attention to prevent further Loss to District or to prevent interruption of operations of District, District will attempt to give immediate notice to Contractor. If Contractor cannot be contacted or does not comply with District's request for correction within a reasonable time as determined by District, District or Separate Contractors under District's direction, may, notwithstanding the provisions of this Article, proceed to make such corrections or provide such attention; and the costs of such correction or attention shall be charged against Contractor. Such action by District will not relieve Contractor of the guarantees provided in this Article or elsewhere in the Construction Contract. Contractor shall replace, repair or restore to District's satisfaction any other parts of the Work and any other real or personal property, which is damaged or destroyed as a result of such Defective Work or the correction of such Defective Work.

12.2.4 Contractor shall promptly remove from the Site those portions of the Work and materials which are not in accordance with the Contract Documents and which are neither corrected by Contractor nor accepted by District.

12.2.5 If Contractor fails to commence correction of Defective Work within seven (7) Days after notice from District or fails to diligently prosecute such correction to completion, District may correct the Defective Work in accordance with Article 2.4; and, in addition, District may remove the Defective Work and store salvageable materials and equipment at Contractor's expense.

12.2.6 If Contractor fails to pay the costs of such removal and storage as required by Articles 12.2.4 and 12.2.5 within seven (7) Days after written demand, District may, without prejudice to other remedies, sell such materials at auction or at private sale or otherwise dispose of such material. Contractor shall be entitled to the proceeds of such sale, if any, in excess of the costs and damages for which Contractor is liable to District, including compensation for District's services and expenses. If such proceeds of sale do not cover costs and



damages for which Contractor is liable to District, the Contract Sum shall be reduced by such deficiency. If there are no remaining payments due Contractor or the remaining payments are insufficient to cover such deficiency, Contractor shall promptly pay the difference to District.

12.2.7 Contractor's obligations under this Article are in addition to and not in limitation of its warranty under Article 3.5 or any other obligation of Contractor under the Contract Documents. Enforcement of Contractor's express warranties and guarantees to repair contained in the Contract Documents shall be in addition to and not in limitation of any other rights or remedies District may have under the Contract Documents or at law or in equity for Defective Work. Nothing contained in this Article shall be construed to establish a period of limitation with respect to other obligations of Contractor under the Contract Documents, which may be longer specified periods. Establishment of the Guarantee To Repair Period relates only to the specific obligation of Contractor to correct the Work and in no way limits either Contractor's liability for Defective Work or the time within which proceedings may be commenced to enforce Contractor's obligations under the Contract Documents.

### **12.3 ACCEPTANCE OF DEFECTIVE WORK**

12.3.1 Notwithstanding the provisions of Article 12.2 of these General Conditions, District shall have the option, at its sole discretion and by notice to Contractor, to accept Defective Work instead of requiring its removal or correction, in which case the Contract Sum shall be reduced by an amount equal to the difference between the value to District the Work would have had were it complete, correct and in conformity with the Contract Documents and the value to District of such Defective Work. Such option shall be exercised solely by notice to Contractor and shall not be implied from any act or omission by District or Construction Manager. If there are no remaining payments of the Contract Sum to be made to Contractor, or if the remaining payments and retention are insufficient to cover the amount of the reduction of the Contract Sum, Contractor shall promptly pay to District the amount of any such deficiency.

---

## **ARTICLE 13 – STATUTORY REQUIREMENTS**

### **13.1 NONDISCRIMINATION/EQUAL OPPORTUNITY**

13.1.1 For purposes of this Article, the term Subcontractor shall not include suppliers, manufacturers, or distributors, except those who will actually perform work on the Site.

13.1.2 Contractor shall comply and shall ensure that all Subcontractors comply with the California Government Code, Section 12900, and the applicable sections that follow.

13.1.3 Contractor agrees as follows during the performance of the Work:

.1 Contractor shall not discriminate against any employee or applicant for employment because of race, color, religion, sex, age, ancestry, national origin, sexual orientation, handicap, veteran's status, medical condition (as defined in the California Government Code, Section 12926), marital status, or citizenship. All applicants for employment and employees are to be treated without regard to their race, color, religion, sex, age, ancestry, national origin, sexual orientation, handicap, veteran's status, medical condition (as defined in the California Government Code, Section 12926), marital status, or citizenship. Such equal treatment shall apply, but not be limited to:

- (i) Employment, upgrading, demotion, or transfer.
- (ii) Recruitment or recruitment advertising.
- (iii) Layoff or termination.
- (iv) Rates of pay or other forms of compensation.
- (v) Selection for training, including apprenticeship.

.2 Contractor agrees to post in conspicuous places, available to employees and applicants for employment, the Notice of Equal Employment Opportunity (EEO) setting forth this provision.

.3 Contractor shall send to each labor union, with which it has a collective bargaining agreement or other contract or understanding, the letter of Concurrence and the Notice of Equal Employment Opportunity (EEO) advising them of Contractor's commitments under this provision; and Contractor shall post copies of the Notice of Equal Employment Opportunity (EEO) in conspicuous places available to employees and applicants for employment. The Notice of Equal Employment Opportunity (EEO) shall be in English and other applicable languages.

.4 Contractor and all Subcontractors will permit access to their records of employment, employment advertisements, application forms, and other pertinent data and records by District or any appropriate District of the State of California designated by District for the purposes of investigation to ascertain compliance with this provision. The outcome of the investigation may result in the following:

a. A finding of willful violation of the provisions of this Construction Contract or of the Fair Employment Practices Act may be regarded by District as either of the following:

(i) A basis for determining that Contractor is not a "responsible bidder" as to future contracts for which such Contractor may submit bids.

(ii) A basis for refusing to accept or consider the bids of Contractor for future contracts.

b. District may deem a finding of willful violation of the Fair Employment Practices Act to have occurred upon receipt of written notice from the Fair Employment Practices Commission that it has done both of the following:

(i) Investigated and determined that Contractor has violated the Fair Employment Practices Act.

(ii) Issued an order under the California Government Code, Section 12970, or obtained an injunction under the California Government Code Section 12973.

c. Upon receipt of such written notice from the Fair Employment Practices Commission, District may notify Contractor that, unless it demonstrates to the satisfaction of District within a stated period that the violation has been corrected, Contractor's bids on future projects will not be considered.

.5 Contractor agrees that, should District determine that Contractor has not complied with this provision, Contractor shall forfeit to District, as a penalty, for each day or portion thereof, for each person who was denied employment as a result of such non-compliance, the penalties provided in Article 13.3 for violation of prevailing wage rates. Such penalty amounts may be recovered from Contractor; and District may deduct any such penalty amounts from the Contract Sum.

.6 Nothing contained in this provision shall be construed in any manner so as to prevent District from pursuing any other remedies that may be available at law.

.7 Contractor shall meet the following standards for affirmative compliance and provide District with satisfactory evidence of such compliance upon District's request, which shall be evaluated in each case by District:

a. Contractor shall notify its Superintendent and other supervisory personnel of the nondiscrimination requirements of the Contract Documents and their responsibilities thereunder.

b. Contractor shall notify all sources of employee referrals (including unions, employment agencies, and the State of California Department of Employment) of the nondiscrimination requirements of the Contract Documents by sending to such sources and by posting the Notice of Equal Employment Opportunity (EEO).

c. Contractor or its representative shall, through all unions with whom it may have agreements, develop agreements that:

(i) Define responsibilities for nondiscrimination in hiring, referrals, upgrading, and training.

(ii) Implement an affirmative nondiscrimination program, in terms of the unions' specific areas of skill and geography, such that qualified minority women, non-minority women, and minority men shall be available and given an equal opportunity for employment.

d. Contractor shall notify District of opposition to the nondiscrimination requirements of the Contract Documents by individuals, firms or organizations during the term of the Contract.

.8 Contractor shall include the provisions of the foregoing Articles 13.1.3.1 through 13.1.3.6 in all subcontracts with Subcontractors, so that such provisions will be binding upon each such Subcontractor.

## **13.2 STATE LABOR LAW**

13.2.1 Contractor, its agents, and employees shall be bound by and comply with all applicable provisions of the Labor Code and such federal, state and local laws which affect the conduct of the Work.

13.2.2 Contractor shall strictly adhere to the provisions of the Labor Code regarding the employment of apprentices; minimum wages; payment of wages; alien labor, the eight- hour day; overtime, Saturday, Sunday and holiday work; registration with the Department of Industrial Relations to maintain eligibility to work on public works; and nondiscrimination because of race, color, national origin, age, marital status, sexual orientation, disability, sex or religion. Contractor shall forfeit to District the penalties prescribed in the Labor Code for violations.

13.2.3 District has ascertained that the general prevailing rate of wages and employer payments for health and welfare, vacation, pensions, and similar purposes applicable to the locality in which the Work is to be done are as set

(v) General Conditions

forth in that certain document entitled, "Prevailing Wage Scale," as indicated in the California Labor Code Part 7, Chapter 1 – Article 2, as determined by the Director of Industrial Relations. Applicable Prevailing Wage Rates and related information not listed are to be obtained from the State of California by Contractor. Contractor shall post a copy of applicable exhibits/wage rates at each Site. Contractor to whom the Construction Contract is awarded and any Subcontractor agree to pay wages and benefits not less than said specified rates to all workers employed by them in the execution of the Construction Contract. A person or concern who fails to do so shall be subject to withholding of contract payments equal to the underpayment of required wages and benefits and subject to the penalties provided for in the California Labor Code, Section 1775. Contractor and each Subcontractor shall prepare and certify their payrolls on forms satisfactory and in accordance with instructions to be furnished by District.

13.2.4 In accordance with the Labor Code, prevailing wage rate determinations for the work to be done on this Project are maintained by the District.

13.2.5 In the event there is a determination that Contractor is in violation of prevailing wage requirements, Contractor shall reimburse District for all investigative costs incurred in addition to any other remedies provided under the Contract Documents.

### **13.3 PAYROLL RECORDS**

13.3.1 Contractor and all Subcontractors shall keep an accurate payroll record, showing the name, address, social security number, job classification, straight time and overtime hours worked each day and week, and the actual per diem wages paid to each journey worker, apprentice worker, or other employee employed in connection with the Work. All payroll records shall be certified as being true and correct by Contractor or Subcontractors keeping such records; and the payroll records shall be available for inspection at all reasonable hours at the principal office of Contractor on the following basis:

.1 A certified copy of an employee's payroll record shall be made available for inspection or furnished to such employee or the employee's authorized representative upon request.

.2 A certified copy of all Contractor and Subcontractor payroll records shall be made available for inspection upon request to District, the State of California Division of Labor Standards Enforcement, and the Division of Apprenticeship Standards of the State of California Division of Industrial Relations. A certified copy of all payroll records shall be furnished to District or its representatives upon request.

.3 A certified copy of all payroll records shall be made available upon request by the public for inspection or copies thereof made; provided, however, that the

request by the public shall be made to either District, the Division of Apprenticeship Standards, or the Division of Labor Standards Enforcement. The public shall not be given access to such records at the principal offices of Contractor or Subcontractors. Any copy of the records made available for inspection as copies and furnished upon request to the public or any public entity by District shall be marked or obliterated in such a manner as to prevent disclosure of an individual's name, address, and social security number. The name and address of Contractor awarded the Construction Contract or performing the Construction Contract shall not be marked or obliterated.

.4 As of April 1, 2015: contractors and subcontractors must furnish electronic certified payroll records to the Labor Commissioner (State of California, Division of Labor Standards Enforcement).

13.3.2 Contractor and all Subcontractors shall file a certified copy of the payroll records with the entity that requested the records within ten (10) Days after receipt of a written request. Contractor shall inform District of the location of such payroll records for the Project, including the street address, District, and county; and Contractor shall, within ten (10) days, provide notice of change of location of such records. In the event of noncompliance with the requirements of Article 13.3 or with the California Labor Code Section 1776, Contractor and its Subcontractors shall have ten (10) Days in which to comply following receipt of a notice specifying in what respects Contractor must comply. Should non-compliance still be evident after the ten (10) Day period, Contractor shall forfeit to District, as a penalty, one hundred dollars (\$100.00) for each Day, or portion thereof, for each worker, until strict compliance is accomplished. Such forfeiture amounts may be deducted from the Contract Sum. Contractor shall include stipulations in all of its subcontracts to ensure that Subcontractors comply with Section 13.3.

## **13.4 APPRENTICES**

13.4.1 Attention is directed to the California Labor Code, Sections 1777.5, 1777.6, and 1777.7 and the California Code of Regulations, Title 8, Section 200, and the applicable sections that follow. To ensure compliance and complete understanding of the law requiring apprentices, and specifically the required ratio thereunder, Contractor or Subcontractors should, where some question exists, contact the State of California Division of Apprenticeship Standards prior to commencement of the Work. Responsibility for compliance with these requirements lies with Contractor

## **13.5 WORK DAY**

13.5.1 Contractor shall not permit any worker to labor more than eight (8) hours during any one (1) Day or more than forty (40) hours during any one (1) calendar week, except as permitted by law and in such cases only upon such conditions as are provided by law. Contractor shall forfeit to District, as a penalty, fifty dollars (\$50.00) for each worker employed in the execution of this Construction Contract

by Contractor, or any Subcontractor, for each Day during which such worker is required or permitted to Work more than eight (8) hours in any one (1) Day and forty (40) hours in any one (1) calendar week in violation of the terms of this provision or in violation of the provisions of any law of the State of California. Such forfeiture amounts may be deducted from the Contract Sum. Contractor and each Subcontractor shall keep, or cause to be kept, an accurate record showing the actual hours worked each Day and each calendar week by each worker employed on the Project, which record shall be kept open at all reasonable hours to the inspection of District, its officers and agents, and to the inspection of the appropriate enforcement agency or representative and the State of California.

**END OF GENERAL CONDITIONS**

**OCEANO COMMUNITY SERVICES DISTRICT**  
**NORSWING/PERSHING WATERLINE REPLACEMENT PROJECT**  
**PLANS AND DRAWINGS**  
**FOR**  
**OCEANO, CA**  
**CONTRACT NO. 2019-03**







**OCEANO COMMUNITY SERVICES DISTRICT**  
**NORSWING/PERSHING WATERLINE REPLACEMENT PROJECT**  
**SPECIAL PROVISIONS AND/OR TECHNICAL SPECIFICATIONS**  
**FOR**  
**OCEANO, CA**  
**CONTRACT NO. 2019-03**

**For Special Provisions and/or Technical Specifications,  
see bid document:**

**“viii” - (REPORTS, SUPPLEMENTS, ATTACHMENTS,  
MODIFICATIONS AND EXHIBITS)**

**San Luis Obispo County Encroachment Permit**

**# ENC 20190249**

**OCEANO COMMUNITY SERVICES DISTRICT**  
**NORSWING/PERSHING WATERLINE REPLACEMENT PROJECT**  
**REPORTS, SUPPLEMENTS, ATTACHMENTS, MODIFICATIONS AND EXHIBITS**  
**FOR**  
**OCEANO, CA**  
**CONTRACT NO. 2019-03**



County of San Luis Obispo
DEPARTMENT OF PUBLIC WORKS

Colt Esenwein, Director
County Government Center, Room 207 - San Luis Obispo CA 93408
Phone: (805) 781-5252 Fax: (805) 781-1229 Email: PW.Permits@co.slo.ca.us

STATUS: ISSUED

UTILITY ENCROACHMENT PERMIT

PERMIT NO: ENC20190249 ISSUED: 2/21/2019

ROAD NO: Norswing Dr - M1101

TO:
Oceano Community Services District
C/O Paavo Ogren
1655 Front St
Oceano, CA 93445

BLD PERMIT: n/a
ROAD CUT (TRANSVERSE): \$0.00
ROAD CUT (LONGITUDINAL): \$0.00
RECEIPT:
TOTAL FEES: \$342.00

INSPECTOR: Mike Tabares 235-3538

DEPOSIT: \$0.00
BOND: \$1,500.00

CONTACT PERSON: Mike Kielborn 805-544-7407

SECTION: 3
WORK ORDER NUMBER: 245R12C104UT
Utility
Encroachment
Inspections

SUBJECT TO THAT THE ATTACHED PROVISIONS, PERMISSION IS HEREBY GRANTED TO:

WORK LOCATION AND DESCRIPTION:

Community: Oceano
Address: Norswing Drive / Pier Ave / Truman Dr / Pershing Dr
APN:

- 1. Oceano Community Services District to install new 8" water main, valves, fire hydrants and service laterals along Norswing Drive, Pershing Drive, Truman Drive and Pier Avenue in accordance to County W-1, W-1a, W-2, W-3, W-4 & W-8 Standards or appropriate OCSO Standards.
2. OCSO, to install new utilities in accordance to County U-1, U-2, U-3b & U-4 Standards.
3. Backfill trench with slurry and pavement repair in accordance to County R-1, R-3 & R-3a Standards.
4. Traffic control in accordance with permit conditions.

AT:
LEGAL DESC:
APN:

STANDARD CONDITIONS AND PROVISIONS

Building Permit No.: n/a
Work Order No.: 245R12C104UT

PERMITTEE IS RESPONSIBLE FOR READING AND ADHERING TO ALL CONDITIONS AND PROVISIONS OF THIS ENCROACHMENT PERMIT. PERMIT HOLDER SHALL CONTACT THE ENCROACHMENT PERMIT INSPECTOR AT (805) 235-3538 AT LEAST TWENTY-FOUR (24) HOURS PRIOR TO COMMENCING WORK, PRIOR TO MILESTONE OBSERVATIONS, AND UPON COMPLETION OF THE WORK FOR A FINAL INSPECTION.

Applicable only for the following county roads:

NORSWING DRIVE #1101 65PCI  
PERSHING DRIVE #1102 35PCI  
PIER AVENUE #1095 73PCI 3526 ADT  
TRUMAN DRIVE #1103 45PCI

Pavement Restoration Requirements for ADT<500:

PCI 85-100 T-Section + Full Lane Overlay  
PCI <85 T-Section

Pavement Restoration Requirements for ADT>500:

PCI 85-100 T-Section + Full Lane Overlay  
PCI 65-84 T-Section + Half Lane Overlay  
PCI <65 T-Section

This encroachment permit may reference plans, exhibits and/or sketches submitted by the permittee during the application process, referenced hereafter as the permit plans. These encroachment permit requirements and provisions supersede all conflicts that may arise from the permit plans.

PERMITTED SHOULDER, LANE, AND ROAD CLOSURES:

Shoulder closures are permitted on:

- NORSWING DRIVE
- PERSHING DRIVE
- PIER AVENUE
- TRUMAN DRIVE

• NO LANE CLOSURES PERMITTED

• NO ROAD CLOSURES PERMITTED

PERMITTED HOURS OF CONSTRUCTION:

• In accordance with County Code 22.10.120 (Noise Standards), Section A.4, noise sources associated with construction must not occur weekdays before 7:00 am or after 9:00 pm; and weekends before 8:00 am or after 5:00 pm.

PERMIT NOT VALID WITHOUT THE FOLLOWING:

• The contractor must be in possession of a valid State of California Contractor's License with the appropriate classification/s for the work being performed, San Luis Obispo County Business License, and Certificate of Insurance with General Liability coverage. Documentation must be provided to the County upon demand.

• Permittee must schedule a preconstruction meeting prior to commencing work. Invitees must include representatives of the owner, the contractor, affected utility companies and community services districts, and the County Public Works Inspector. Evidence of coordination must be provided to the County upon demand.

• The USA ticket number is written below (Permittee is responsible for marking the area of work with white paint prior to calling USA for underground facility location):

---

• Prior to commencing any work the Permittee must acquire permission from the respective utility owner prior to impacting their facilities and appurtenances. Evidence of permission must be provided to the County upon demand.

• The Permittee must coordinate work with the fronting property owner/s. Evidence of coordination must be provided to the County upon demand.

• The Permittee must secure all Environmental Permit Clearance. Copies of permits or evidence that

permits are not required must be provided to the County upon demand.

#### UTILITIES:

Permit not Valid without USA Membership - Every operator of a subsurface installation, except the Department of Transportation, shall become a member of, participate in, and share in the costs of, a regional notification center, (USA). Ca. Govt. Code Sections 4216-4216.9

a. "Operator" means any person, corporation, partnership, business trust, public agency, or other entity which owns, operates, or maintains a subsurface installation. For purposes of Section 4216.1 an "operator" does not include an owner of real property where subsurface facilities are exclusively located if they are used exclusively to furnish services on that property and the subsurface facilities are under the operation and control of that owner.

b. "Subsurface installation" means any underground pipeline, conduit, duct, wire, or other structure, except nonpressurized sewer lines, nonpressurized storm drains, or other nonpressurized drain lines.

- The utility owner shall maintain ownership of all abandoned facilities and shall continue to mark these facilities for USA requests. When abandoned facilities conflict with future County utility or road projects, the utility owner shall assist the County in locating the abandoned utility in the right-of-way, and if necessary, remove those portions of abandoned facilities that would be in conflict with the proposed improvements

- All utilities and appurtenances work must be located and constructed in accordance with County U Series Drawings. Location per the appropriate U-1 and U-2, separation per U-3, and trenching (if permitted) per U-4 series drawings.

- All pavement repair work must be performed accordance with the PAVEMENT RESTORATION requirements specified herein this permit and the R-series drawings.

- All unyielding above grade utilities and appurtenances must be set back from the nearest edge of travel lane to provide a minimum 10-foot clear zone, or in accordance with the clearance requirements of Section 4.1.9A of the County Public Improvement Standards. The use of appurtenances such as bollards, walls, or similar utility protection devices is not permitted.

- The maximum length of the active work zone (defined as the partially open, open, or partially restored trench) must not exceed six hundred (600) feet.

- Use of shoulder area for construction staging requires pre-approval by the County's encroachment permit inspector.

- Minimum crossing clearance between new utilities and a county drainage culvert shall be 24-inches measured from the outside edges.

- Any excavation greater than five (5) feet deep must be properly sloped or shored in conformance with the requirements of the State of California Division of Industrial Safety.

PERMIT HOLDER SHALL CONTACT THE ENCROACHMENT PERMIT INSPECTOR AT LEAST TWENTY-FOUR HOURS PRIOR TO COMMENCING WORK AND AFTER COMPLETION OF WORK FOR A FINAL INSPECTION.

1. All work will be conducted in accordance with the County Standards and Specifications, Encroachment Permit Conditions, California Manual of Uniform Traffic Control Devices, State Standards and Specifications, State Streets and Highways Code, State Vehicle Code, and the attached Provisions. All work within the right of way of a county maintained road shall be performed by an appropriately licensed and bonded contractor, and shall provide traffic control per the latest California Manual of Uniform Traffic Control Devices.

All encroachments shall be installed and maintained per San Luis County Department of Public Works Public Improvement Standards, including but not limited to, Horizontal Clear Zone Standards, Vertical Clear Zone Standards, and Sight Distance Standards. Please visit the county website to view Public Improvement Standards:

<http://www.slocounty.ca.gov/Departments/Public-Works/Forms-Documents/Development-Services/Public-Im>

2. County Code 13.08.130 - Permittee's liability - Each applicant is solely responsible for any damage or liability occurring by reason of anything done, or omitted to be done, by applicant or its or his agents, employees, or independent contractors directly responsible to applicant, or in connection with any work or authority delegated under any permit issued as result of an application; and each applicant shall, to the extent permitted by law, indemnify and save harmless the county, its officers, agents, employees or servants from any and all loss or liability resulting from any claims made by reason of, or in connection with, any work done under the authority of, or as a result of, any permit issued hereunder.
3. Vehicle Obstruction of the Travel Way – An unobstructed width of the highway opposite a standing vehicle shall be left for the free passage of other vehicles (Vehicle Code, Division 11, Chapter 9 [22500 – 22526]. Two 10-foot travel lanes shall be provided at all times, except for when the temporary traffic control plan is being implemented in accordance with this permit. This permit may be revoked by the Department in the event that the applicant or his assigns encroach upon the free passage of other vehicles.
4. Permittee shall be aware that utility and/or structural encroachments placed within the right-of-way are the permittee's responsibility to properly maintain in perpetuity and that said encroachment may require removal or alteration due to the maintenance/construction requirements of public utilities, County Public Works Department or other public agency.
5. This encroachment within the road right of way is permitted with the understanding that all encroachments placed within the right-of-way is “at risk” from future county road maintenance or utility projects and shall be the sole responsibility of the permittee. By accepting this permit, the permittee acknowledges that, pursuant to Section 1463 of the California Streets and Highways Code, the permit is revocable upon five (5) days’ notice from the Public Works Department. Upon such notice the encroachment must be removed or replaced as specified by the Public Works Department at the owner's sole expense.
6. If at any time the encroachment poses a hazard or nuisance within the right-of-way the County may immediately remove or by notice may require the removal of such encroachment (1480 of the Street and Highways Code).
7. If required, a cash deposit has been posted by the permittee. It is agreed that funds will be drawn from the deposit to pay the actual costs of any action taken by the County to correct any unsafe condition that may arise during the course of the above permitted activity.
8. The permittee agrees to pay penalties for violation to the conditions of this permit. The conditions in violation shall be considered as “illegal encroachments” imposed by the permittee in the right of way and subject to penalties of \$350 per day under Streets and Highways Code 1483. The penalties shall accrue daily for each and every violation of the conditions of the permit. These violations of conditions may include, but not be limited to: Initiating Lane Closure Work Hours prior to the hours listed in the permit; Exceeding Lane Closure Work Hours beyond the hours listed in the permit; Having trench excavation plates which are not recessed or flushing to the travel surface (for each plate); Having trench plates which do not have a uniform and complete skid resistant surface (for each plate); Failure to restore the bike lanes to operation per the Lane Closure Work restrictions listed in the permit; Failure to provide an adequate hot mix asphalt (HMA) surface once trench plates are no longer utilized (cold mix not an adequate treatment); Failure to adhere to the approved traffic control plan for the work; Failure to place temporary pavement stripe markers (flopies); Parking equipment within ten (10) feet of the travel-way during non-work hours; Storing materials within ten (10) feet of the travel way during non-work hours; Failure to sweep debris from the travel lanes and improved shoulders, within the work zone, at the end of each work day; and closing or blocking a bus stop without advanced notification and clearance from the transit authority. Full payment of any outstanding penalties must be received prior to issuance of any subsequent encroachment permits to permittee or contractor.

SURVEY MONUMENT PRESERVATION:

1. In accordance with the Streets & Highways Code 1492.5 and the State of California Business and Professions Code 8771, prior to commencing work the permittee shall, under the direction of a licensed land surveyor or registered civil engineer, locate all survey monuments within the work zone and file a corner record or record of survey of the references with the county surveyor if the monument could be destroyed, damaged, covered, or otherwise obliterated. Prior to completion of the permitted work all damaged monuments shall be reset in the surface of the new construction, a suitable monument box placed thereon, or permanent witness monuments set to perpetuate their location; and a new corner record or record of survey of the references shall be filed with the county surveyor. It shall be the responsibility of the permittee to provide for the monumentation required by this section.

#### BORE UTILITIES UNDER PAVED ROADWAYS IS REQUIRED:

1. Unless otherwise permitted herein, no cutting of or trenching within the paved roadway surface is allowed under this permit, all non-gravity utilities shall be bored in accordance with the following:

- a. If trenching or cutting of pavement becomes required to conduct this work, notify the encroachment inspector to allow for an amendment to the permit.
- b. Coring in the paved surface to locate existing utilities in advance of boring operations shall be done by vacuum truck with an eight (8) inch diameter maximum hole. Core holes shall be backfilled with vibrated 2 sack concrete slurry, and paved in kind to match existing asphalt thickness.
- c. Bore pits shall be located at least 10-feet clear from the nearest edge of pavement, and at least 5-feet outside the toe of slope in embankment areas. Bore pits must be adequately shored and fenced.
- d. The alignment of the boring and subsequent utility must be either parallel or perpendicular to the roadway.
- e. The excavation for the boring operation shall be kept to a minimum, but shall be of sufficient dimensions to satisfactorily complete the work. The conductor pipe shall be placed behind and in conjunction with the boring operation. The bored hole shall not be more than two inches in diameter larger than the conductor pipe. Guide rails shall be accurately set to line and grade so as to achieve close adherence to the crown of pipe at a minimum depth of 30". Approved material shall be pumped into completely fill annular space around conduit for its full length.
- f. Boring entrance and exit pits requiring access through portland cement roadway sections shall be backfilled with 3 sack slurry, and paved in kind to match existing asphalt thickness.
- g. Boring operations shall comply with the latest version of State of California DOT TR-0163 (Underground Utility Provisions), hereby known as the "Provisions", unless specifically approved otherwise by the Department. A Class C-34 (Pipeline) Contractor license is required either bore and jack or Horizontal Directional Drilling (HDD) encasement installation operations within the County right-of-way.
- h. HDPE is acceptable as casing material with HDD. The casing shall be plugged, but not grouted. When required by the Department, voids shall be grouted from within, in accordance with the Provisions. Wing type cutters shall not be used unless specifically approved by the Department. Casings shall typically be extended to the right-of-way line.

#### PAVEMENT RESTORATION:

1. Trench restoration shall be completed in accordance with County R-1, R-3 and/or R-3a standard drawings.
2. Pavement restoration shall be completed in accordance with County R-1, R-2, R-2a and/or R-4 standard drawings.
3. For trenching in roads that have an existing concrete structural section the pavement repair shall be "in-kind". Number 4 (1/2") dowels, 18-inch long shall be placed every 5-feet on-center, equally staggered along both sides of the trench, and embedded a minimum of 6-inches into the midpoint of the existing concrete section. The new concrete section shall be 520-lbs/cy (5.5-sack min.) and match the thickness of the existing section. After curing, the final Hot Mix Asphalt T-section shall be placed in accordance with County R-series standards.
4. Whenever 60% of the traveled way is damaged by construction activities, the entire width of the travel lane or bike lane shall be repaved per County Standard R-1. Paving shall be in accordance with State



Standards Section 39.

5. Compaction tests shall be made on sub-grade material and material as specified by the permit inspector. Said tests shall be made prior to the placing of the next material. Subgrade material shall be compacted to a relative compaction of 95% in the zone between finished subgrade elevation and a minimum of 30" below. All material in fill sections below the zone mentioned above shall be compacted to 95% relative compaction.
6. Hot Mix Asphalt (HMA) shall conform to requirements for Type A asphalt as specified in Section 39 of the State Standards for one-half (½) inch mix. Asphalt binder shall conform to PG 64-13.
7. Hot Mix Asphalt (HMA) shall be placed in lifts not exceeding three (3) inches in a single lift and shall cool to 150-degrees prior to laying subsequent lift(s).
8. Removal of existing pavement striping or markings shall be by sandblasting, hydro blasting, or grinding. When the change of position will be greater than two (2) feet, the removed striping shall be further obscured by use of a Chip Seal, as required by Section 9.1.2 D of the Public Improvement Standards. The Chip Seal shall extend the full width of the roadway
9. Pavement marking and delineation shall be two-component traffic paint with retro-reflective glass beads. The material shall be listed on the Caltrans Authorized Product List for traffic paint and shall conform to the layouts shown in the State Standard Plans. Thermoplastic may be used with prior approval by the inspector.
10. Temporary floppy markers (flopies) shall be applied the day of paving to delineate pavement stripes and shall be maintained until final striping has been completed.
11. All joints shall have a 4" fog spray of SS1H oil. Contractor shall follow up with striping as soon as practical or as directed by the inspector.

TRAFFIC CONTROL:

1. The contractor shall be responsible for providing traffic control throughout all phases of work in accordance with Part 6 of the California Manual on Uniform Traffic Control Devices (CA MUTCD). Contact the Public Works Inspector for additional information.
2. No work shall commence without the Construction Signs installed and other necessary traffic control devices on site. Stationary mounted construction area signs shall be fluorescent orange, using materials from the Caltrans "Prequalified Products List" for signing and Delineation Materials. The list is available at the website of the Caltrans Office Engineer: [www.dot.ca.gov/hq/esc/approved\\_products\\_list/](http://www.dot.ca.gov/hq/esc/approved_products_list/)
3. At a minimum, CA MUTCD W20-1 (CA Code C23), "ROAD WORK AHEAD", signs shall be placed and maintained at all times in both directions on all affected streets, from the start of construction until acceptance by the County Public Works Department.
4. Where bike lanes are impacted, traffic control shall also include a W20-5 (BIKE LANE CLOSED) and a W11-1 & W16-1 combination (SHARE THE ROAD) signs in the affected direction.
5. Where sidewalks are impacted, traffic control shall also include signage per TA-28 Sidewalk Detour of Diversion.
6. Where parking is impacted, parking pre-notification R30B or similar no parking signs shall be placed a minimum of seventy-two (72) hours in advance of starting construction.
7. Where County traffic signals may be impacted, the contractor shall coordinate work zone traffic control with County Transportation (805-781-5252) at least 48-hours prior to performing any shoulder, lane or road closure.

8. All flaggers shall be trained in accordance with the California Code of Regulations, Title 8, Section 1599(f), and use Personal Protective Equipment (PPE) consistent with section 6E.02 of CA MUTCD. Part 6 of the CA MUTCD is available on line at <http://www.dot.ca.gov>

9. Shoulder Closures (If Permitted Herein) - Traffic control shall be placed according to Chapter 6 of the CA MUTCD (typical applications are TA-3 or TA-5 for multiple day; and TA-4 or TA-6 for single day closures). Twenty (20) feet or more of roadway must be maintained for two way traffic.

10. Lane Closures (If Permitted Herein) - Traffic control shall be placed according to Chapter 6 of the CA MUTCD (typical applications are TA-10 (CT-T13) or TA-10A; TA-11 for lane closure on roads with traffic volumes 500 ADT or less, and 25 mph speeds or less). Typical applications for multi-lane highways are RSPT-11 for one lane or RSPT-12 for both lanes. Concurrent lane closure on the same road IS NOT permitted. Traffic cycles through the work zone must not exceed 20-minute delay to the public. One lane must remain traversable at all times to cycle traffic through the work zone as expedient as possible. Unless otherwise noted, the open (traversable) lane must maintain a minimum of 10 feet in width as measured to the near face of the channelizing devices. Where the opposite shoulder is suitable for carrying vehicular traffic and of adequate width, lanes may be shifted by use of closely-spaced channelizing devices, provided that the minimum lane width of 10 feet is maintained.

11. Road Closures (If Permitted Herein) - Traffic control shall be placed according to Chapter 6 of the CA MUTCD (typical applications are TA-9, TA-19, and TA-20 for detour routes). Other requirements include a minimum of 72-hour advanced notification to all impacted property owners and the following agencies: California Highway Patrol, County Sheriff, County Cal Fire, County Public Works, and San Luis Ambulance; and a minimum of 72 hour advance notice and continuous operation using Changeable Message Signs.

12. No construction related signs, delineators, or other obstacles that prevent use shall be placed on a paved shoulder in advance of the work zone. Unobstructed paved shoulder access for pedestrians and bicyclists shall be maintained through the work zone to the greatest extent possible.

13. The contractor shall be responsible for providing and/or maintaining all weather access at all times to existing properties located in the vicinity of work. Additionally, they shall be responsible for maintaining all existing services, including utility, garbage collection, mail distribution, etc., to all existing properties located in the work zone.

14. Delineators shall be equipped with nighttime reflective bands and spaced no greater than 50-foot intervals along tapers, lane control, and/or edge of work zone.

#### PEDESTRIAN PROTECTION:

1. The permittee shall be responsible for constructing and maintaining pedestrian protection devices at all times and in accordance with the California Manual of Uniform Traffic Control Devices (CA-MUTCD), and the California Building Code (CBC). If permitted herein, sidewalk closures must conform to Part 6 of the CA-MUTCD, including TA-28 and TA-29; and pedestrian protection through a construction zone must conform to CBC §3306, including barricades, railings, covered walkways.

#### END OF EACH WORKING DAY:

1. At the conclusion of each work day, all traveled-way surfaces and shoulders shall be restored to an all-weather, traversable condition. There shall not be a drop-off of traveled way greater than 0.15 feet. "Low Shoulder" signs shall be placed along the traveled way where there is any drop-off. Such temporary patching or other field approved surfacing shall be kept in a smooth, firm, dust-free condition for the safe use of the public for no more than 30 days or the final surface patch is required. Cold mix asphalt may be used as a temporary patch material.

2. Steel plates must be friction coated for traction. Plates located in a bike lane or on a paved shoulder subject to bike traffic must have a skid resistant surface which is not raised or otherwise abrupt to a cyclist. On roads with prevailing speeds of 40 mph or greater the plates must be recessed flush with the adjacent pavement by cold planing to a depth equal to the thickness of the plate, and to a width and length equal to

the dimensions of the plate. On roads with prevailing speeds less than 40 mph the steel plates shall be attached to the roadway by a minimum of 2 dowels pre-drilled into each of the 4 corners of the plate and drilled 2" into the pavement. Fine graded asphalt concrete shall be compacted to form ramps, maximum slope 8.5% with a minimum 12" taper to cover all edges of the steel plates. When steel plates are removed, the dowel holes in the pavement shall be backfilled with graded fines of asphalt concrete mix. (All steel plate bridging shall conform to Caltrans TR-0157)

3. All paved road surfaces (lanes, shoulders, sidewalks, ramps, etc.) must be swept clean and the site left in a clean and orderly condition with erosion control measures in-place.

#### ENVIRONMENTAL:

1. In the event archeological resources are unearthed or discovered during construction activities associated with this permit all work must immediately cease and the permit inspector notified. Work may only resume after a mitigation plan to avoid the resources to the maximum degree feasible has been approved by the County.

2. All mitigation required by project environmental permits will be the responsibility of the permittee. Applicable permits may include local agency, U.S. Army Corps of Engineers, the California Regional Water Quality Control Board/State Water Resources Control Board, and/or the California Department of Fish & Game. The permittee must submit copies of each environmental permit to the County Department of Public Works prior to release of improvement security.

#### EROSION CONTROL:

1. Erosion control measures for wind, water, material stockpiles, and tracking shall be implemented at all times by the contractor and shall include source control, including protection of stockpiles, protection of slopes, protection of all disturbed areas, protection of accesses, and perimeter containment measures. Erosion control shall be placed prior to the commencement of work based upon location, site characteristics or time of year. The intent of erosion control measures shall be to keep all generated sediments from entering a swale, drainage way, watercourse, atmosphere, or migrate onto adjacent properties or onto the public right-of-way.

2. The contractor shall be responsible for the placement and maintenance of all storm water control measures/devices and shall be available, installed, and/or applied between October 15 and April 15 or anytime the rain probability exceeds 30% per the satisfaction of the permit inspector and the County Public Improvement Standards.

3. In the event of a failure, the contractor shall be responsible for cleanup and all associated costs or damage. In the event that damage occurs within the right-of-way and the County is required to perform cleanup, the permittee shall be responsible for reimbursing the County all associated costs.

#### USE OF ROAD SHOULDER (IF SPECIFICALLY PERMITTED):

1. Use of a county shoulder for construction staging and material storage must have prior approval from County Public Works.

2. Unless permitted otherwise, no construction equipment or materials shall be parked or stored within ten (10) feet of the edge of traveled way or conflict with access to properties, utilities, etc.

3. The shoulder area shall be signed as closed and portable delineators used to mark a taper in advance of the material or equipment. All delineators shall be equipped with nighttime reflective bands and spaced no greater than 25-foot intervals along the edge of work zone.

4. Safe public (pedestrian) access to the road shoulder between the edge of pavement and stockpile must be provided at all times.

5. No vehicle maintenance shall be allowed at any time.

6. Upon completion of work the shoulder must be returned to a condition equal to or better than

pre-disturbed conditions, and to the satisfaction of the county encroachment permit inspector.

7. Requirements for storage of erosive materials including road base and native soil (must be specifically permitted):

a. An erosion control plan (or SWPPP if required) must be prepared and implemented by the permittee.

b. Stockpiles shall be located a minimum of 10-feet away from the nearest edge of traveled way of the adjacent public road(s); 50-feet away from water bodies such as creeks, rivers and drainage courses; shall not be located in environmentally sensitive areas; shall not be located on slopes greater than 20%; and shall not remain longer than 6-months without prior written approval from the Department.

c. All stockpiles should be shaped, not left in an "end dump condition"; should have a slope of 3:1 or flatter with the top surface sloped downhill at minimum of 0.5% and a maximum of 5%; should not exceed 20 feet in height; and no one stockpile should exceed 5,000 cubic yards. Adjacent stockpiles should not be located closer than 50-feet to each other.

d. All stockpiles regardless of time of year shall have silt fence installed immediately around the perimeter at the toe of slope. This silt fence shall be maintained until stockpile is removed.

e. Between April 15th and October 15th stockpiles remaining inactive for longer than one (1) week shall be covered with plastic or otherwise protected to control dust.

f. Between October 15th and April 15th (rainy season) stockpiles shall be stripped of plastic coverings and appropriate Best Management Practices that reduce erosion potential and stabilize the slopes (i.e. hydro-seeding, straw, straw wattles etc.) shall be implemented.

g. Once a stockpile is removed the area below shall be returned to the original contours or final project finished grades with established vegetation.

## ENCROACHMENT PERMIT PROVISIONS

### GENERAL

1. Authority – This permit is issued pursuant to Chapter 13.08 of the San Luis Obispo County Code and Chapter 5.5 (commencing with Section 1450) of the Division 2 of the California Streets and Highways Code, the provisions of which are incorporated herein by reference as though fully set forth herein. Special event permits with are issued pursuant to Chapter 15.610 of the San Luis Obispo County Code and Chapter 2 (commencing with Section 942) of the Division 2 of the California Streets and Highways Code, the provisions of which are incorporated herein by reference as though fully set forth herein. Issuance or denial of permit may be appealed to the Board of Supervisors. All board decisions are final and conclusive.

2. Definitions – The word "County" as used herein means the County of San Luis Obispo acting by and through its Director of Public Works or his duly authorized representative. The word "work" as used herein means allowed activities in the County of San Luis Obispo right-of-way as specified in the encroachment permit.

3. No Precedent Established – This permit is granted with the understanding that this action is not to be considered to establish a precedent concerning any kind of encroachment within the county right-of-way.

4. Permits from Others – When the law requires the consent to any work hereunder from any other public board or person having jurisdiction, this permit shall be suspended unless and until such consent is obtained.

5. Permission from Property Owners – Whenever it is necessary to secure permission from abutting property owners, such authority must be secured by the permittee prior to the starting of work.

6. Responsible Party – No party other than the named permittee or their agent is authorized to work under any permit.

7. Notice Prior to Starting Work – Before starting work under the encroachment permit, the permittee shall notify the County 24-hours prior to initial start of work.

8. Indemnity – The permittee shall defend, indemnify and save harmless the County of San Luis Obispo, its officers, agents and employees from any and all claims, demands, damages, costs, expenses, or liability that relate in any way to this permit, including, but not limited to, any act or omission on the part of the permittee, or of agents, employees, or independent contractors directly responsible to the permittee; including, but not limited to, any defects, flaws or errors in the design or performance of any work under this permit, providing further that the foregoing shall apply to any acts, or omissions to act, committed jointly or concurrently by the permittee, the permittee's agents, employees or independent contractors, and the County, its agents, employees or independent contractors. Nothing contained in the foregoing indemnity provisions shall be construed to require the permittee to indemnify the County against any responsibility or liability in contravention of Section 2782 of the Civil Code.

9. Other Work – This permit is to be strictly construed, and no work other than that specifically mentioned is authorized hereby.

10. Safety – All work shall be performed in a safe and workmanlike manner in accordance with all applicable laws and regulations.

11. Keep Permit on the Job – This permit shall be kept at the site of the work and shall be shown to any representative of the County, or any law enforcement officer on request.

12. Protection of the Public – The work shall cause the least possible inconvenience to the traveling public. Two-way traffic shall be maintained from the close of the working day to the start of the next working day. County approval required for shoulder, lane, and road closures. All warning signs, lights, devices, and procedures shall conform to the latest California Manual of Uniform Traffic Control Devices (CA MUTCD). All traffic associated with the work shall follow the provisions of the California Vehicle Code.

13. Standards of Construction – Any matter not specifically mentioned herein, or covered by direct reference, shall conform to the latest adopted County Public Improvement Standards, and, if not covered therein, to Caltrans Standard Specifications and Plans.

14. County Inspection – All work shall be subject to County inspection and performed in accordance with latest adopted County Public Improvement Standards and to the satisfaction of the County.

15. Expense of Inspection – On work which in the judgment of the County requires the presence of an employee of the Department of Public Works as inspector, the actual cost (including salary, traveling expense, and overhead) of such inspection shall be paid by the permittee upon presentation of a statement therefore. The cost of any tests required by the County shall be borne by the permittee.

16. Security – The applicant shall provide a cash security (with assignment to the County of San Luis Obispo) in the amount specified on the encroachment permit which sum is deemed sufficient by the County and which deposit aforesaid shall guarantee payment to the County of San Luis Obispo for all costs of work of improvement, engineering, inspection, maintenance, and related incidental expenses done or incurred by the County as is provided for herein. Expense of County costs shall be paid current and/or the finalization of encroachment permit is required prior to release of security.

17. Restoration of Right-of-Way – All portions of the right-of-way, and all adjacent areas directly affecting such, if disturbed by work pursuant to this permit, shall be promptly restored to prior condition (including the replacement of suitable material and/or the planting of vegetation) and shall be left in a presentable condition.

18. Existing Utilities – The permittee shall contact all utilities to determine the location of any existing facilities prior to any excavation. The underground Service Alert ticket number and name shall be kept on the job site and be available to any representative of the County or any law enforcement officer on request. The permittee shall also contact the local water purveyor, sanitation district or other utility not affiliated with Underground Service Alert to advise them of the proposed project. The date and name of this contact must also be kept on the job site. The permittee shall immediately notify the owning utility of any damage to the

existing facility.

19. Future Moving of Installation – In the event it becomes necessary, in the opinion of the County, to remove or relocate the encroachment permitted hereunder, such shall be accomplished by, and at the sole expense of, the permittee, and within such time and manner as may be required by the County. (Curb and gutter improvements constructed in accordance with approved plans are exempted from this provision).

20. Taxation of Possessory Interests – Permittee recognizes and understands that this permit may create a possessory interest subject to property taxation, and that permittee may be subject to payment of taxes levied on such interest.

21. Joint and Several Obligation – If there is more than one permittee subject to the terms of this permit, then all of the terms of this permit shall bind the permittees individually and collectively, and said permittees shall be individually and collectively liable therefore.

22. Maintenance – The permittee agrees by the acceptance of this permit to exercise reasonable care to maintain properly any encroachment placed by it in the highway and to exercise reasonable care in inspecting for and immediately repairing and making good any injury to any portion of the highway which occurs as a result of the maintenance of the encroachment in the highway or as a result of the work done under this permit, including any and all injury to the highway which would not have occurred had such work not been done or such encroachment not placed therein.

23. Clear Zone – Any work performed in the right-of-way shall be designed and constructed so that a 10-foot wide area beside the edge of traveled way is clear of any obstructions. No above grade unyielding fixed objects shall be constructed within this clear zone unless specifically permitted by the County. The County may consider construction within the clear zone when it is designed in a manner to break away easily if hit by a moving vehicle.

#### USA MEMBERSHIP REQUIREMENTS

1. California Law – Every operator of a subsurface installation, except the Department of Transportation, shall become a member of, participate in, and share in the costs of, a regional notification center, (USA). Cal. Govt. Code Sections 4216-4216.9. "Operator" means any person, corporation, partnership, business trust, public agency, or other entity which owns, operates, or maintains a subsurface installation. For purposes of Section 4216.1 an "Operator" does not include any owner of real property where subsurface facilities are exclusively located if they are used exclusively to furnish services on that property and the subsurface facilities are under the operation and control of that owner. "Subsurface installation" means any underground pipeline, conduit, duct, wire, or other structure, except non-pressurized sewer lines, non-pressurized storm drains, or other non-pressurized drain lines.

#### UTILITY AND UNDERGROUND

1. Cutting Pavement – All construction in asphalt shall be bored wherever possible. Open cut construction must be specifically permitted or may be authorized by the County to accommodate unexpected field conditions. When pavement is cut it shall be done in a manner which causes the least possible damage to the adjacent pavement. After the utility is placed and the trench backfilled and based, the pavement shall be trimmed by sawing or other approved means to a sufficient width to removal displaced or damaged pavement. If the trench edge is within 2-feet of the edge of the roadway pavement, the entire 2-feet shall be removed and replaced.

2. Backfill – Bedding and shading material shall be consolidated and compacted by a field approved method. Backfill material shall be consolidated and compacted to the following standards: (U-4 Series Drawings). Compaction tests shall be taken in locations as determined by the County. If approved by the County, excavations may be backfilled with vibrated sand slurry, or two sack cement slurry. All tests shall be conducted using Caltrans test methods.

3. Replacement of Pavement – The surface of all trenches in the traveled way shall be temporarily patched

or otherwise surfaced at the end of each working day. Such temporary patching or other field approved surfacing shall be kept in a smooth, firm, dust-free condition for the safe use of the public for no more than 30-days before the final surface patch is required. Cold mix asphalt may be used as a temporary patch material; however, recessed metal plates are required on all arterial and major collector streets. Steel plate bridging shall conform to State Standards TR-0157. After the ditch edges have been trimmed, the base and pavement shall be replaced. The thickness of the base and paving to be replaced shall be determined in the field and shall be at least equal in section to that adjacent to the trench area; however, no pavement shall be less than 3-inches thick. Pavement shall be replaced with Type A hot mix asphalt which shall conform to State requirements for ½-inch maximum medium grading. Base material shall conform to State requirements for Class 2 Aggregate Base.

4. Plowing – The use of a static plow within 5-feet of the edge of the pavement is prohibited. A vibrating plow may be used to within 1-foot off the edge of the pavement. Any pavement that is broken or otherwise disturbed by the plowing operations shall be removed and replaced. After plowing and prior to any compaction efforts, the plow trench shall be flooded to attain a plastic condition. The trench shall then be compacted by wheel rolling or other suitable means.

5. General – Minimum cover over utilities shall conform to the Standard U-1 drawing for installation. Maximum length of work under construction at any time shall not exceed 500 feet. Disposal of spoil material shall be in a legal manner and outside the right-of-way unless otherwise specifically approved by the County. Reasonable care shall be taken to avoid damage to major roots of trees. If an independent contractor installs a utility, the operator of the utility must accept the work before final approval of the work by the County.

6. Responsibility for Failures – The utility/service company that required the installation of facilities within the limits of the County right-of-way shall assume maintenance responsibility, in perpetuity, for any damage/failure to facilities owned and/or maintained by the County of San Luis Obispo as a result of such installation.

**All Other Permits Shall Be The Permittee's Responsibility to Obtain.**

**NOTICE OF START OF CONSTRUCTION SHALL BE GIVEN TO THIS DEPARTMENT AT LEAST TWENTY-FOUR HOURS IN ADVANCE. NOTICE OF COMPLETION SHALL BE GIVEN TO THIS DEPARTMENT. CALL Mike Tabares 235-3538 FOR INSPECTIONS.**

The conditions and restrictions of this permit must be acknowledged below by the Permittee and a signed copy returned to County Public Works. Acknowledgement indemnifies the County from any claims that may relate per the application form and the herein permit conditions and provisions.

\_\_\_\_\_  
Signature

\_\_\_\_\_  
Name

\_\_\_\_\_  
Title

\_\_\_\_\_  
Date

Attachment:

Plans/Drawings

Encroachment Permit Standard Drawings: R-1, R-3, R-3a, U-1, U-2, U-3b, U-4, W-1, W-1a, W-2, W-3, W-4, W-8

The work herein permitted under **ENC20190249** shall be completed before: 03/31/2019

Issuance of Permit approved by:  
COLT ESENWEIN, DIRECTOR



---

RENE BRILL

Work Completed:

---

Inspector

Date



Revisions

Description	Approved	Date	Description	Approved	Date

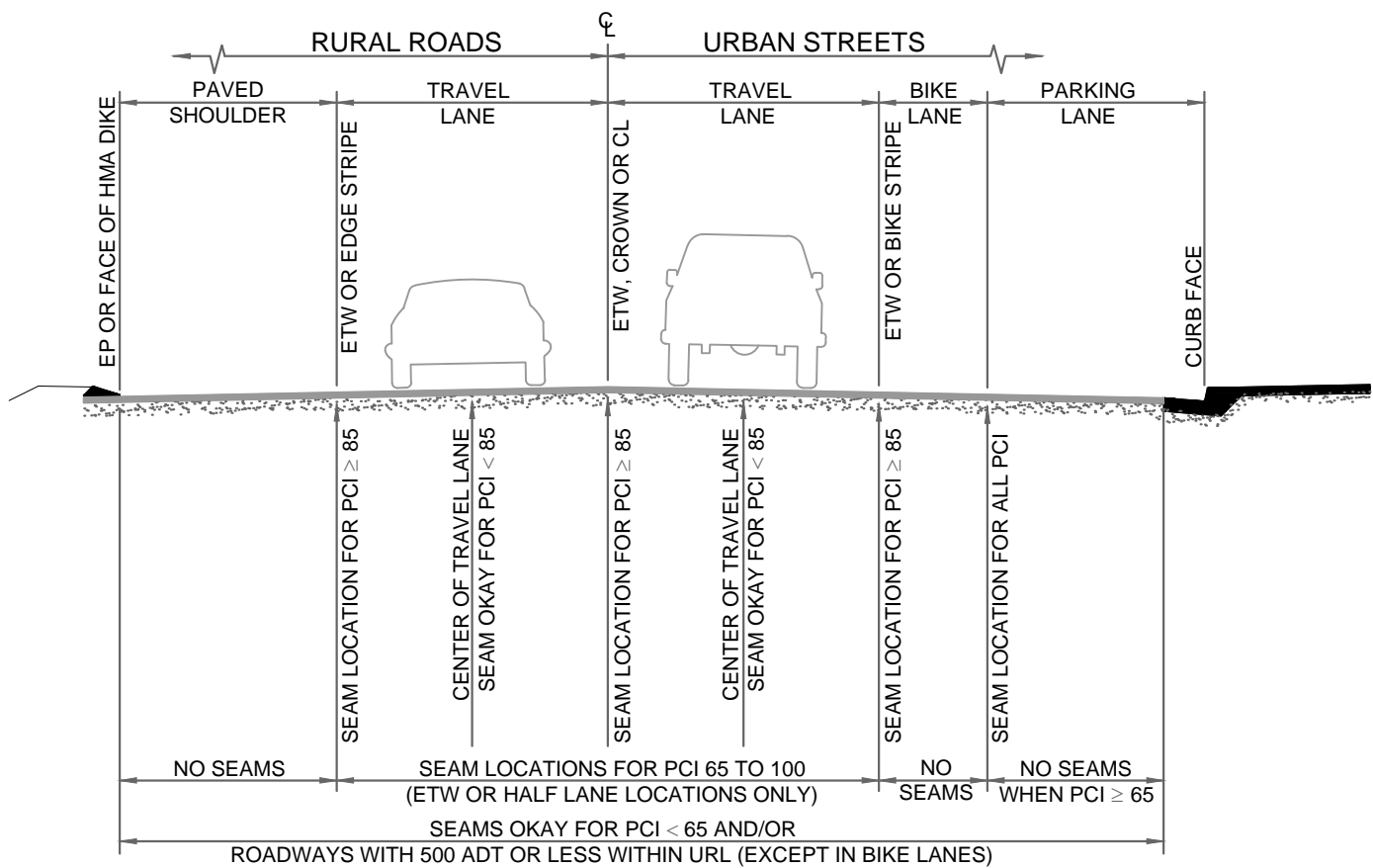

**SECTION VIEW: ALLOWABLE PAVEMENT SEAM LOCATIONS**  
 BASED ON ROAD PCI & ADT AS PROVIDED BY THE DEPARTMENT

PCI	Roadways with 500 ADT or less and within the URL	
	Full Lane Width Overlay	All Other Roadways
85-100	Full Lane Width Overlay	Full Lane Width Overlay
65-84	12" min. T-Section	Half Lane Width Overlay
<65	12" min. T-Section	12" min. T-Section

**MINIMUM PAVEMENT REPAIR LIMITS**

ADT = AVERAGE DAILY TRAFFIC, AS PROVIDED BY THE DEPARTMENT  
 PCI = PAVEMENT CONDITION INDEX, AS PROVIDED BY THE DEPARTMENT  
 ETW - EDGE OF TRAVELED WAY; OL - OVERLAY; URL - URBAN RESERVE LINE

**NOTES:**

- SEAM LOCATIONS MAY BE ADJUSTED BY THE DEPARTMENT BASED ON FIELD CONDITIONS.
- IN ALL CASES THE EXISTING PAVEMENT SHALL BE SAWCUT ALONG A CLEAN LINE AND SHALL BE EITHER LONGITUDINAL OR TRANSVERSE TO THE TRAVEL LANE. NO LONGITUDINAL SEAMS SHALL BE ALLOWED WITHIN ANY BIKE LANE.
- ALL SAWCUT EDGES SHALL BE VERTICAL, WITH SQUARE CORNERS, AND SHALL BE STRAIGHT AND NEAT IN APPEARANCE.
- ROTMILLING OR GRINDING MAY BE UTILIZED IN PLACE OF SAWCUT WHEN APPROVED IN ADVANCE OF THE WORK BY THE DEPARTMENT.
- SEE R-2 SERIES DRAWING FOR RURAL ROAD AND URBAN STREET WIDENING SAWCUT REQUIREMENTS. SEE R-3 SERIES DRAWINGS FOR UTILITY TRENCHING SAWCUT REQUIREMENTS.
- A TACK COAT SHALL BE APPLIED TO ALL HORIZONTAL AND VERTICAL SAWCUT CONFORM SURFACES PRIOR TO PAVING.
- AFTER PAVING, SS1H OIL (OR APPROVED EQUAL) SHALL BE APPLIED TO ALL HMA SURFACE SEAMS PER MANUFACTURER'S RECOMMENDATIONS.



DEPARTMENT OF PUBLIC WORKS & TRANSPORTATION  
**ALLOWABLE PAVEMENT SEAM LOCATIONS**

Scale: NTS	Adopted: 2014
Drawing No:	<b>R-1</b>
Sheet No:	1 OF 1

Revisions

Description	Approved	Date	Description	Approved	Date
REVISE NOTES 2 AND 3	FH	AUG 14			

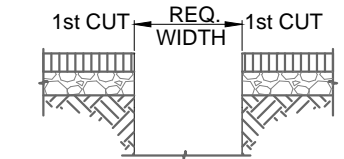

STEP 1: SAWCUT TO CONSTRUCT TRENCH PER U-4.

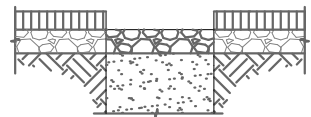

STEP 2: BACKFILL & COMPACT NEW TRENCH TO TOP OF EXISTING BASE SECTION PER U-4.

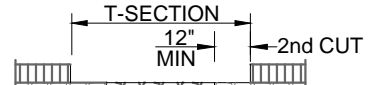

STEP 3: SAWCUT PER NOTE 1 TO REMOVE AN ADDITIONAL 12" MIN OF ASPHALT SURFACE.

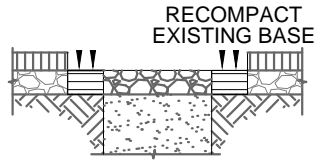

STEP 4: RECOMPACT EXISTING BASE SECTION TO 95% RELATIVE COMPACTION.

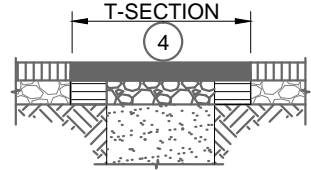

STEP 5: PAVE ROADWAY PER NOTE 3.

Table 1: Min. Trench Length Pavement Repair Limits (see R-1)

PCI	Roadways with 500 ADT or less and within the URL	All Other Roadways
	85-100	Overlay To Lane Edge
65-84	12" min. T-Section	Overlay To Lane Center
<65	12" min. T-Section	12" min. T-Section

PAVEMENT REPAIR PROCEDURE

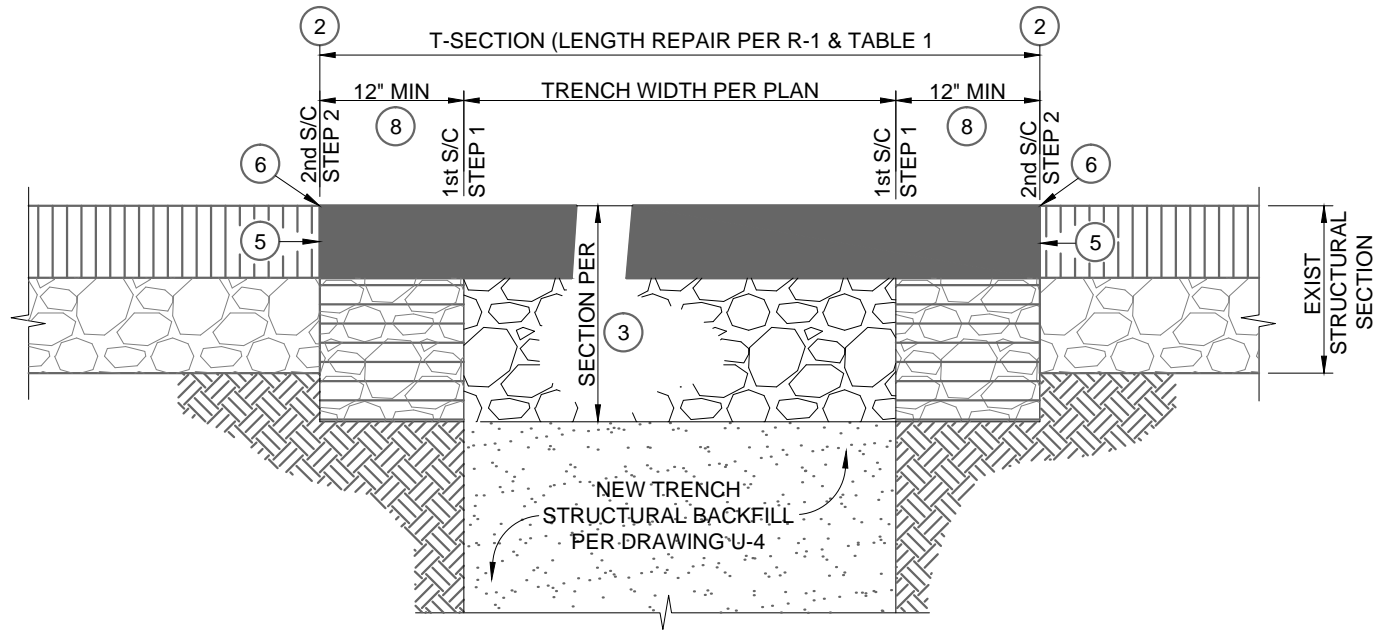

SECTION VIEW

NOTES:

- TRENCHING IN A ROADWAY IS ONLY ALLOWED WHEN BORING IS SHOWN TO THE DEPARTMENT AS BEING INFEASIBLE.
- SAWCUT TO REMOVE DAMAGED OR FAILED PAVEMENT SECTION ADJACENT TO THE EDGE OF TRENCH AS NECESSARY TO PROVIDE A CLEAN JOIN LINE. ALL SAWCUTS SHALL BE PERPENDICULAR OR PARALLEL TO THE TRAVEL LANE. SEAMS SHALL NOT BE ALLOWED WITHIN DESIGNATED BICYCLE LANES. ALL CUT EDGES SHALL BE VERTICAL WITH SQUARE CORNERS AND SHALL BE STRAIGHT AND NEAT IN APPEARANCE. ALL SAWCUTS SHALL BE TO MINIMUM SHOWN OR TO COMPETENT PAVEMENT SECTION.
- THE STRUCTURAL ROAD REPAIR SECTION SHALL MATCH THE EXISTING STRUCTURAL SECTION THICKNESS OR AS REQUIRED BY THE DEPARTMENT. TYPICAL ROAD WIDENING SECTION SHALL BE:
  - 2" MINIMUM HOT MIX ASPHALT (HMA), OVER
  - 6" MINIMUM CLASS II AGGREGATE BASE, OVER
  - TRENCH SECTION PER DRAWING U-4 (STRUCTURAL BACKFILL TO 95% MIN RELATIVE COMPACTION)
- NEW PAVEMENT SHALL BE PLACED IN LIFTS NOT EXCEEDING 3-INCHES (COMPACTED).
- A TACK COAT SHALL BE APPLIED TO ALL HORIZONTAL AND VERTICAL CONFORM SURFACES PRIOR TO PAVING.
- AFTER PAVING, APPLY SS1H OIL (OR APPROVED EQUAL) TO ALL HMA SURFACE SEAMS PER MANUFACTURER'S RECOMMENDATIONS.
- THE DEPARTMENT SHALL PROVIDE ADDITIONAL REQUIREMENTS WHEN TRENCHING IN EXISTING ROADS HAVING CONCRETE STRUCTURAL SECTIONS.
- T-SECTION WIDTHS SHALL BE INCREASED AS DIRECTED BY THE DEPARTMENT FOR UTILITY PIPES EXCEEDING 36" IN DIAMETER.



DEPARTMENT OF PUBLIC WORKS & TRANSPORTATION  
**TRENCH REPAIR**  
 TRANSVERSE TRENCHES AND BORE PITS

Scale: NTS	Adopted: 2014
Drawing No:	<b>R-3</b>
Sheet No:	1 OF 1

Revisions

Description	Approved	Date	Description	Approved	Date
NOTES 1, 3 & 5, STEP 6-ALT, GRIND & OVERLAY TRAVEL LANE	GDM	JAN 11			
REVISE NOTES 2 AND 3	FH	AUG 14			

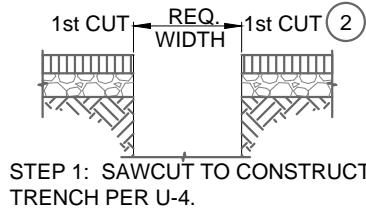

STEP 1: SAWCUT TO CONSTRUCT TRENCH PER U-4.

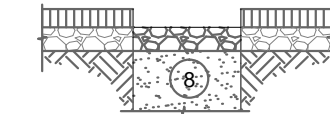

STEP 2: BACKFILL & COMPACT NEW TRENCH SECTION PER U-4.

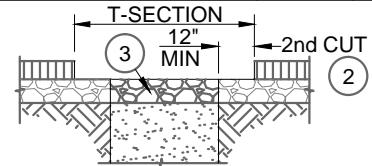

STEP 3: SAWCUT PER NOTE 2 TO REMOVE AN ADDITIONAL 12" MIN OF HMA SURFACE.

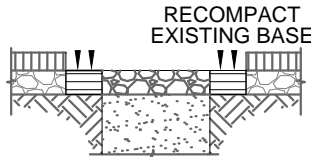

STEP 4: RECOMPACT EXISTING BASE SECTION TO 95% RELATIVE COMPACTION.

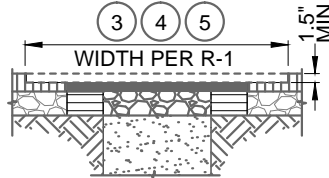

STEP 5: PAVE T-SECTION THEN GRIND 1.5" EXISTING SURFACE PER TABLE 1.

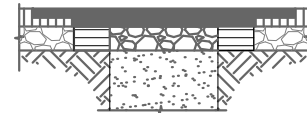

STEP 6: PAVE ROADWAY TO CONFORM TO FINAL GRADE.

PAVEMENT REPAIR PROCEDURE

Table 1: Minimum Lane Width Repair Limits (see R-1)

PCI	Roadways with 500 ADT or less and within the URL		All Other Roadways
	85-100	65-84	
85-100	Full Lane Width Overlay	Full Lane Width Overlay	Full Lane Width Overlay
65-84	12" min. T-Section	12" min. T-Section	Half Lane Width Overlay
<65	12" min. T-Section	12" min. T-Section	12" min. T-Section

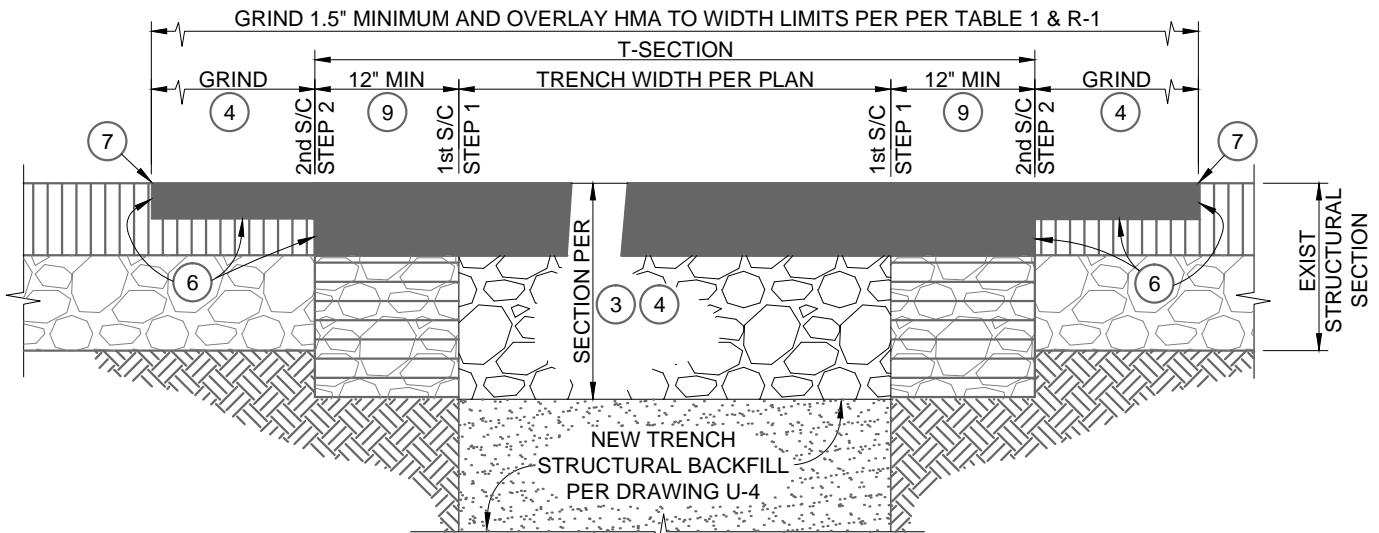

SECTION VIEW

NOTES:

- TRENCHING IN A ROADWAY IS ONLY ALLOWED WHEN BORING IS SHOWN TO THE DEPARTMENT AS BEING INFEASIBLE.
- SAWCUT TO REMOVE DAMAGED OR FAILED PAVEMENT SECTION ADJACENT TO THE EDGE OF TRENCH AS NECESSARY TO PROVIDE A CLEAN JOIN LINE. ALL SAWCUTS SHALL BE PERPENDICULAR OR PARALLEL TO THE TRAVEL LANE. CUT EDGES SHALL BE VERTICAL WITH SQUARE CORNERS AND SHALL BE STRAIGHT AND NEAT IN APPEARANCE. ALL SAWCUTS SHALL BE TO MINIMUM SHOWN OR TO COMPETENT PAVEMENT SECTION.
- THE STRUCTURAL ROAD REPAIR SECTION SHALL MATCH THE EXISTING STRUCTURAL SECTION THICKNESS OR AS REQUIRED BY THE DEPARTMENT. THE MINIMUM STRUCTURAL SECTION SHALL BE:
  - 2-INCH MINIMUM HOT MIX ASPHALT (HMA), OVER
  - 6-INCH MINIMUM CLASS II AGGREGATE BASE, OVER
  - TRENCH SECTION PER DRAWING U-4 (STRUCTURAL BACKFILL TO 95% MIN RELATIVE COMPACTION)
- LONGITUDINAL: GRIND 1.5-INCHES (MINIMUM) FROM THE EXISTING ADJACENT HMA PAVEMENT SO THAT FINAL HMA SEAMS ARE LOCATED IN ACCORDANCE WITH TABLE 1 & DRAWING R-1, OR AS DIRECTED BY THE DEPARTMENT.
- NEW HMA PAVEMENT SHALL BE PLACED IN LIFTS NOT EXCEEDING 3-INCHES (COMPACTED) AND SHALL BE ALLOWED TO COOL PER STATE SPECIFICATIONS PRIOR TO APPLICATION OF SUBSEQUENT LIFTS.
- A TACK COAT SHALL BE APPLIED TO ALL HORIZONTAL AND VERTICAL CONFORM SURFACES PRIOR TO PAVING.
- AFTER PAVING APPLY SS1H OIL (OR APPROVED EQUAL) TO ALL HMA SURFACE SEAMS PER MANUFACTURER'S RECOMMENDATIONS.
- THE DEPARTMENT SHALL PROVIDE ADDITIONAL REQUIREMENTS WHEN TRENCHING IN EXISTING ROADS HAVING CONCRETE STRUCTURAL SECTIONS.
- T-SECTION WIDTHS SHALL BE INCREASED AS DIRECTED BY THE DEPARTMENT FOR UTILITY PIPES EXCEEDING 36" IN DIAMETER.



DEPARTMENT OF PUBLIC WORKS & TRANSPORTATION  
**TRENCH REPAIR**  
 LONGITUDINAL TRENCHES

Scale: NTS	Adopted: 2014
Drawing No: <b>R-3a</b>	
Sheet No:	1 OF 1

Revisions

Description	Approved	Date	Description	Approved	Date
ADD NOTE 10	REM	NOV 07	REV. NOTE 10. REV. MINIMUM COVER OVER GAS MAIN	FH	AUG 14
MODIFY NOTE 1, MIN SD COVER, JOINT TRENCH NOTE	GDM	JAN 11			

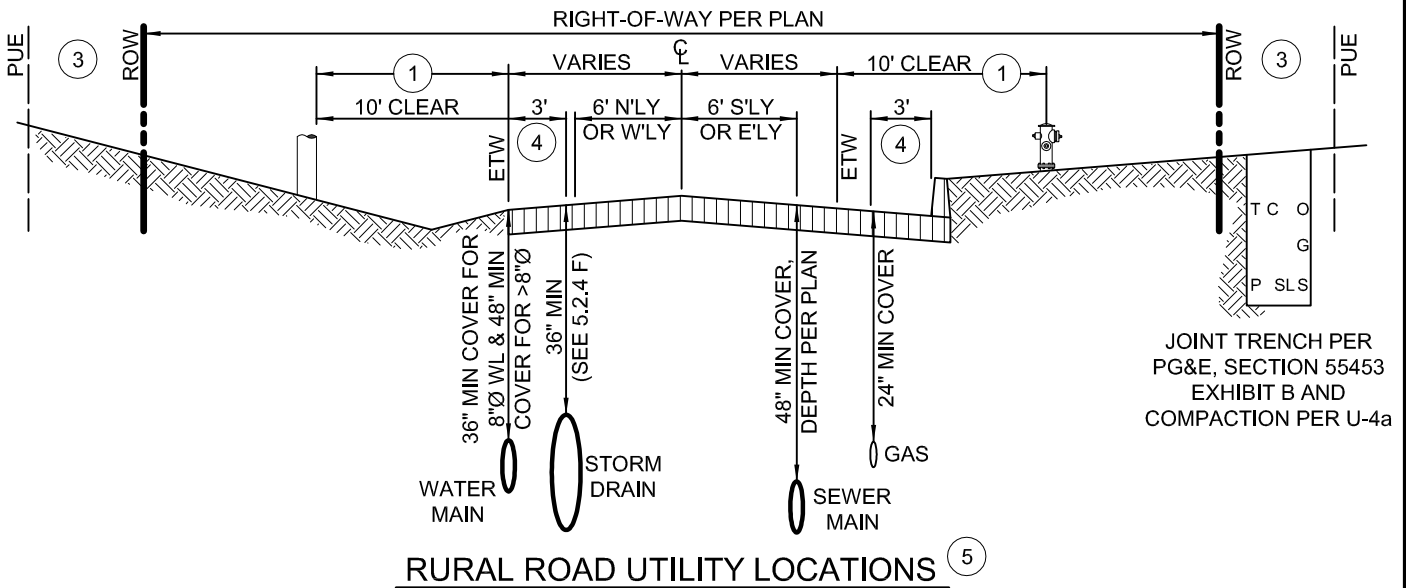
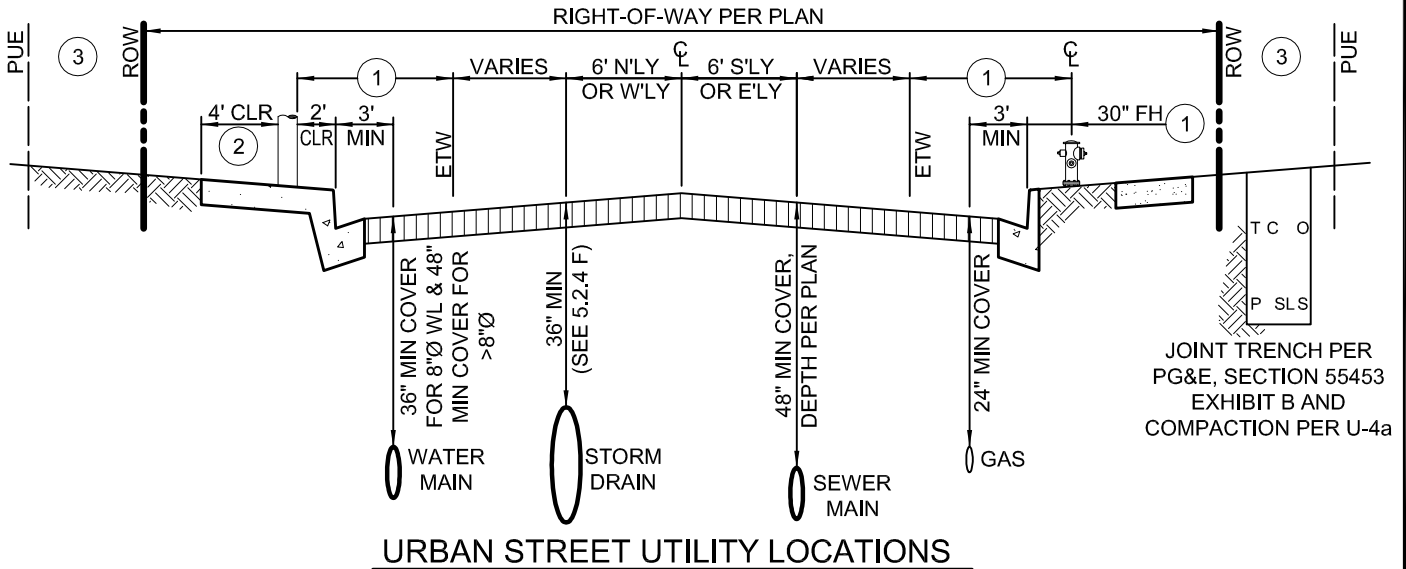

NOTES:

1. ALL ABOVE GRADE FIXED OBJECTS (UTILITY POLES, LIGHT STANDARDS, ETC.) SHALL BE LOCATED AT LEAST 10-FOOT CLEAR FROM THE EDGE OF TRAVELED WAY.
2. PROVIDE 4-FOOT UNOBSTRUCTED CLEARANCE BETWEEN ALL ABOVE GRADE OBSTACLES AND THE BACK OF SIDEWALK (MAY REQUIRE ADDITIONAL SIDEWALK WIDENING).
3. LOCATE UTILITY VAULTS, METER BOXES, PEDESTALS, TRANSFORMERS, ETC. WITHIN PUE AND NOT WITHIN THE SIDEWALK.
4. FOR RURAL ROAD CONDITIONS, GAS AND WATER LINES SHALL BE LOCATED AT 3-FOET OFF FACE OF DIKE OR AT EDGE OF PAVEMENT.
5. THE DEPARTMENT MAY REQUIRE URBAN ROAD UTILITY STANDARD LOCATIONS FOR RURAL ROADS.
6. STREET CROSSINGS OF WIRE AND GAS UTILITIES SHALL REQUIRE A MINIMUM 30" OF COVER AND SHALL BE AT RIGHT ANGLES TO THE ROADWAY CENTERLINE.
7. ABOVE GRADE UTILITY APPURTENANCES SHALL BE LOCATED AS TO MEET DEPARTMENT SIGHT DISTANCE REQUIREMENTS (REFER TO A-5 SERIES DRAWINGS).
8. REFER TO STANDARD DRAWING U-2 FOR LOCATION OF SERVICE LATERALS AND WATER METER BOXES.
9. UNDER NO CIRCUMSTANCES SHALL UTILITY LIDS AND CONCRETE COLLARS BE LOCATED WITHIN CURBS, GUTTERS, SIDEWALKS, DRIVEWAY APRONS, CURB RAMPS, OR CROSS GUTTERS.
10. PROVIDE 12-INCH MINIMUM CLEARANCE BETWEEN STORM DRAIN CROSSINGS WITH WATER AND SEWER LINES. MINIMUM 4-FOET CLEARANCE AT JOINTS.



DEPARTMENT OF PUBLIC WORKS & TRANSPORTATION

LOCATION OF UTILITIES

Scale: NTS	Adopted: 2014
Drawing No: <b>U-1</b>	
Sheet No:	1 OF 1

Revisions

Description	Approved	Date	Description	Approved	Date

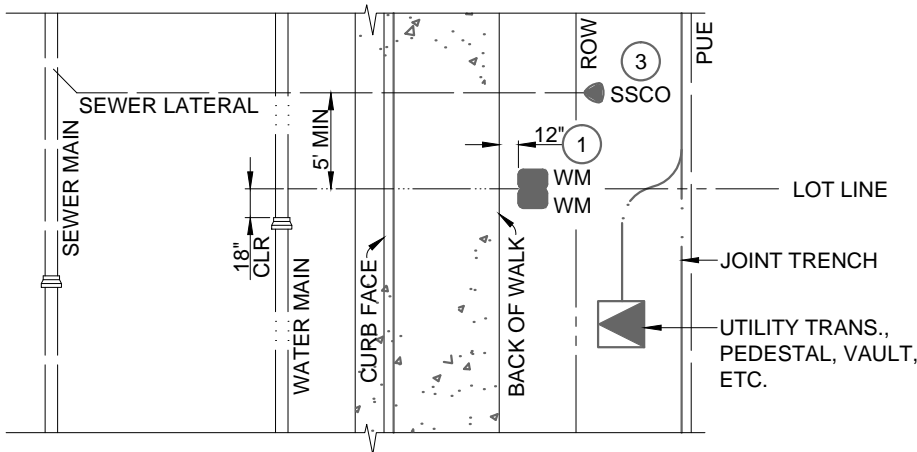

URBAN CURB, GUTTER & SIDEWALK

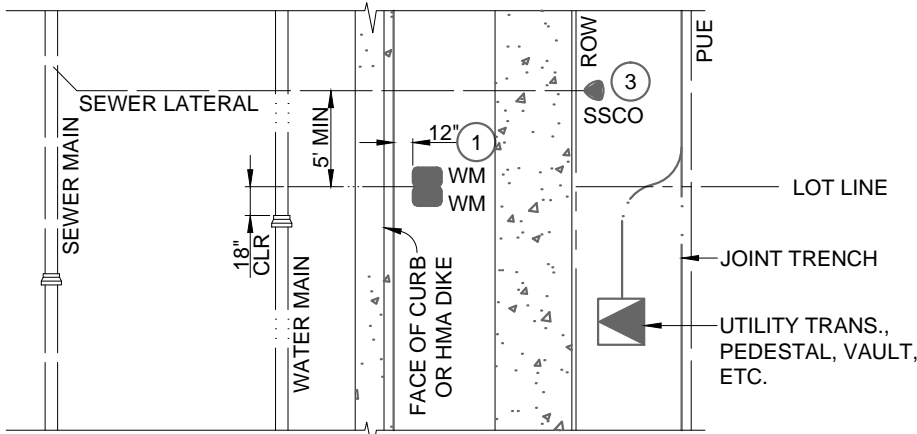

RURAL HMA DIKE OR URBAN CURB WITH DETACHED SIDEWALK

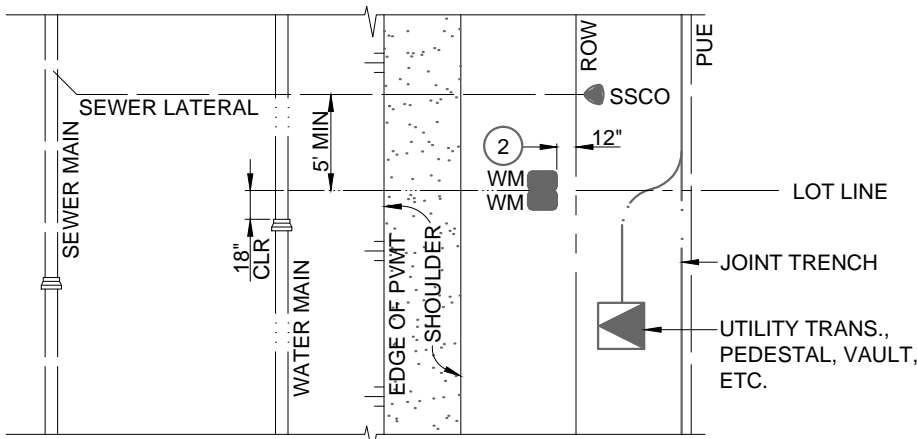

RURAL EDGE OF PAVEMENT

NOTES:

1. LOCATE WATER METER VAULT 12" BEHIND BACK OF CURB OR BACK OF AC DIKE.
2. LOCATE WATER METER VAULT 12" INSIDE RIGHT-OF-WAY.
3. SEWER CLEAN-OUTS SHALL BE LOCATED OUTSIDE OF SIDEWALK AND DRIVEWAY AREAS.
4. ALL WATER METER VAULTS (BOXES) SHALL BE PER STANDARD DRAWINGS.
5. WIRE UTILITY JOINT TRENCH AND APPURTENANCES ARE SHOWN FOR REFERENCE ONLY. REFER TO THE RESPECTIVE UTILITY COMPANY'S HANDOUT PACKAGE FOR ACTUAL ALIGNMENTS AND CONSTRUCTION REQUIREMENTS.
6. WATER AND SEWER SERVICE LATERALS SHALL BE PERPENDICULAR TO THEIR RESPECTIVE MAIN LINES FOR EASE OF LOCATION. ALL WATER LINE TRENCHES SHALL HAVE BOTH TRACE WIRE AND TAPE, REFER TO STANDARD TRENCH DRAWINGS.
7. FOR UNPAVED AREAS, THE WATER METER BOX SHALL BE SET 1" TO 1-1/2" ABOVE FINISHED GRADE.



DEPARTMENT OF PUBLIC WORKS & TRANSPORTATION  
**LOCATION OF SERVICE LATERALS**

Scale: NTS	Adopted: 2014
Drawing No: <b>U-2</b>	
Sheet No: 1 OF 1	

Revisions

Description	Approved	Date	Description	Approved	Date

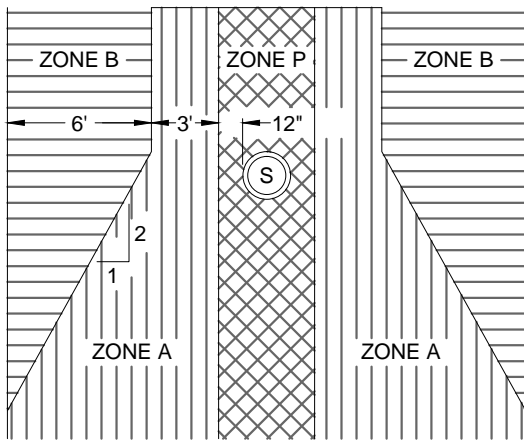

PARALLEL

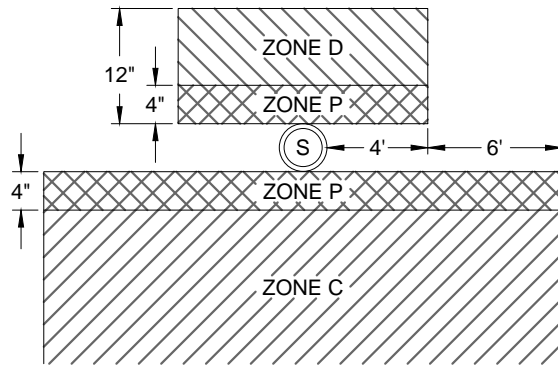

CROSSING

ZONE	SPECIAL CONSTRUCTION REQUIRED FOR WATER:
A	NO WATER MAINS PARALLEL TO SEWERS SHALL BE CONSTRUCTED WITHOUT APPROVAL FROM THE HEALTH AGENCY.
B	IF THE SEWER PARALLELING THE WATER MAIN DOES NOT MEET THE CASE 1, ZONE B REQUIREMENTS, THE WATER MAIN SHALL BE CONSTRUCTED OF: 1. DUCTILE IRON PIPE WITH HOT DIP BITUMINOUS COATING. 2. CLASS 200 PRESSURE RATED PLASTIC WATER PIPE (DR 14 PER AWWA C900) OR EQUIVALENT.
C	IF THE SEWER CROSSING THE WATER MAIN DOES NOT MEET THE CASE 1, ZONE C REQUIREMENTS, THE WATER MAIN SHALL HAVE NO JOINTS IN ZONE C AND BE CONSTRUCTED OF: 1. DUCTILE IRON PIPE WITH HOT DIP BITUMINOUS COATING. 2. CLASS 200 PRESSURE RATED PLASTIC WATER PIPE (DR 14 PER AWWA C900) OR EQUIVALENT.
D	IF THE SEWER CROSSING THE WATER MAIN DOES NOT MEET THE CASE 1, ZONE D REQUIREMENTS, THE WATER MAIN SHALL HAVE NO JOINTS WITHIN 4- FEET FROM EITHER SIDE OF THE SEWER AND SHALL BE CONSTRUCTED OF: 1. DUCTILE IRON PIPE WITH HOT DIP BITUMINOUS COATING. 2. CLASS 200 PRESSURE RATED PLASTIC WATER PIPE (DR 14 PER AWWA C900) OR EQUIVALENT.
P	ZONE P IS A PROHIBITED ZONE, SECTION 64630(E)(2) CALIFORNIA ADMINISTRATIVE CODE, TITLE 22.

**CASE 2: NEW WATER MAIN**

ALTERNATIVE CONSTRUCTION CRITERIA  
APPLIES TO NEW WATER MAINS OR EXISTING SEWER MAINS



DEPARTMENT OF PUBLIC WORKS & TRANSPORTATION  
**UTILITY SEPARATION CRITERIA**  
CASE 2: NEW WATER MAINS

Scale: NTS	Adopted: 2014
Drawing No: <b>U-3b</b>	
Sheet No:	3 OF 3



Revisions

Description	Approved	Date	Description	Approved	Date
LOCATION OF DETECTOR WIRE & TAPE, NOTES 4 & 5	REM	NOV 07	NOTE 7 & REPLACE AC W/ HMA	GDM	JAN 11
MISC CLARIFICATION	GDM	NOV 08			

WHEN TRENCHING INTO EXISTING ROADS ALL WORK SHALL BE DONE IN ACCORDANCE WITH STANDARD DRAWINGS R-1 AND R-4.

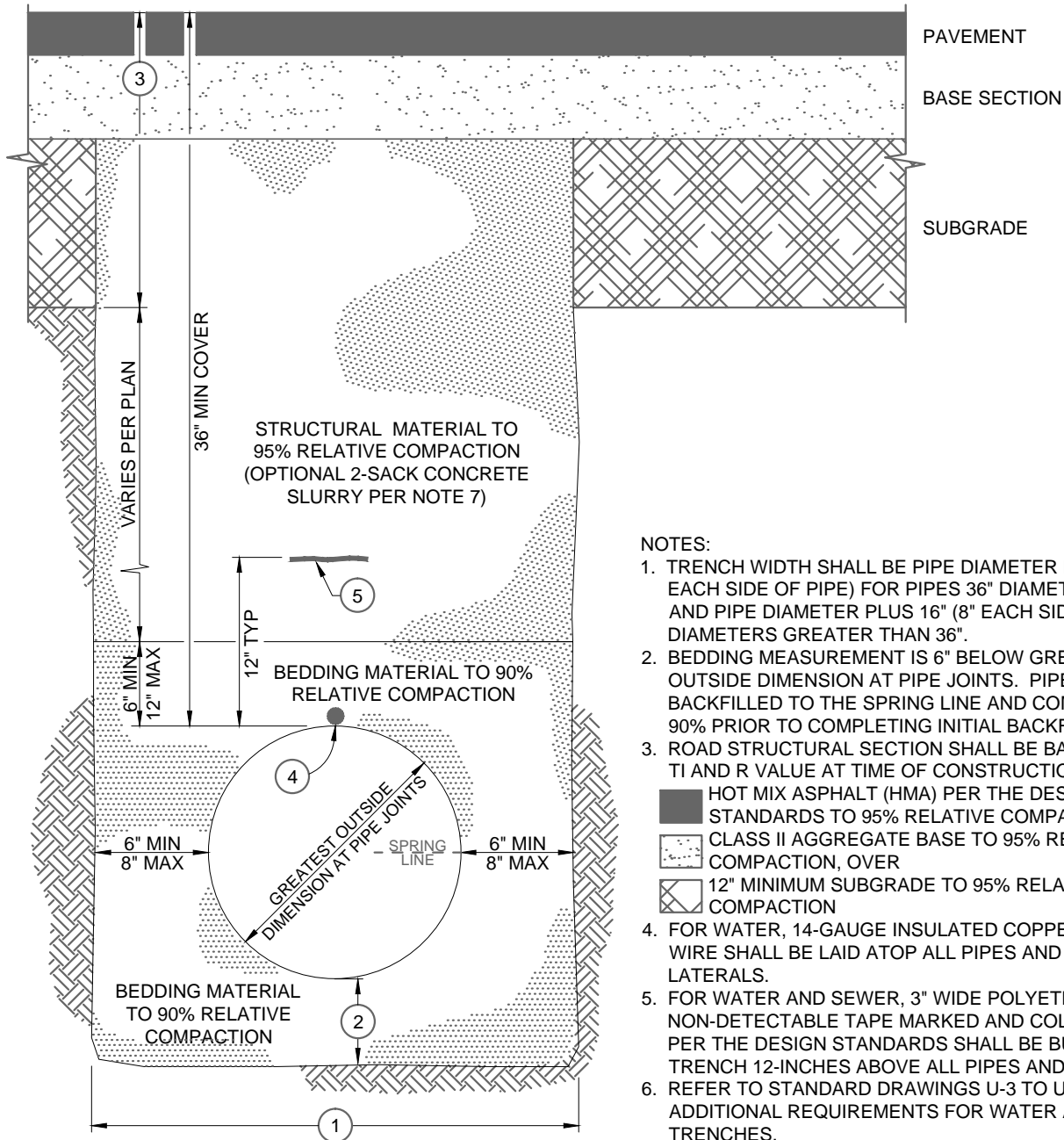

NOTES:

- TRENCH WIDTH SHALL BE PIPE DIAMETER PLUS 12" (6" EACH SIDE OF PIPE) FOR PIPES 36" DIAMETER OR LESS, AND PIPE DIAMETER PLUS 16" (8" EACH SIDE) FOR PIPE DIAMETERS GREATER THAN 36".
- BEDDING MEASUREMENT IS 6" BELOW GREATEST OUTSIDE DIMENSION AT PIPE JOINTS. PIPE SHALL BE BACKFILLED TO THE SPRING LINE AND COMPACTED TO 90% PRIOR TO COMPLETING INITIAL BACKFILL.
- ROAD STRUCTURAL SECTION SHALL BE BASED ON THE TI AND R VALUE AT TIME OF CONSTRUCTION:
  - HOT MIX ASPHALT (HMA) PER THE DESIGN STANDARDS TO 95% RELATIVE COMPACTION, OVER
  - ▨ CLASS II AGGREGATE BASE TO 95% RELATIVE COMPACTION, OVER
  - ▩ 12" MINIMUM SUBGRADE TO 95% RELATIVE COMPACTION
- FOR WATER, 14-GAUGE INSULATED COPPER TRACER WIRE SHALL BE LAID ATOP ALL PIPES AND SERVICE LATERALS.
- FOR WATER AND SEWER, 3" WIDE POLYETHYLENE NON-DETECTABLE TAPE MARKED AND COLOR CODED PER THE DESIGN STANDARDS SHALL BE BURIED IN THE TRENCH 12-INCHES ABOVE ALL PIPES AND LATERALS.
- REFER TO STANDARD DRAWINGS U-3 TO U-3b FOR ADDITIONAL REQUIREMENTS FOR WATER AND SEWER TRENCHES.
- CONCRETE SLURRY TRENCH BACKFILL SHALL CONFORM TO STATE STANDARD 90-1.01, 188 LBS/CY CEMENTITIOUS MATERIAL [2 SACK], TO SURFACE OF BASE COURSE SECTION. DO NOT PLACE AGGREGATE BASE ABOVE SLURRY BACKFILL.

BEDDING MATERIAL		STRUCTURAL MATERIAL	
SIEVE SIZES	PERCENT PASSING	SIEVE SIZES	PERCENT PASSING
1"	100%	3"	100%
No. 4	80% - 100%	No. 4	35% - 100%
No. 200	0% - 15%	No. 30	20% - 100%



DEPARTMENT OF PUBLIC WORKS & TRANSPORTATION  
**TRENCH DETAIL**  
 PAVED SURFACES

Scale: NTS	Adopted: 2014
Drawing No: <b>U-4</b>	
Sheet No:	<b>1 OF 1</b>

**Revisions**

Description	Approved	Date	Description	Approved	Date
ADDED NOTE 3	REM	NOV 07			
TABLES 1 & 2, NOTE 4, SHT 1/2	GDM	JAN 11			

**TABLE 1**

Pipe Dia (in)	Pipe Class	Nom. I.D. (in)	Area (A) (sq in)	THRUST (T) AT FITTING, lbs				
				TEES	90° BEND	45° BEND	22.5° BEND	11.25° BEND
4"	PVC Class 165 (DR 25)	4.39	15	3,254	4,602	2,491	1,270	638
4"	PVC Class 235 (DR 18)	4.23	14	4,005	5,664	3,065	1,563	785
4"	PVC Class 305 (DR 14)	4.07	13	4,619	6,532	3,535	1,802	905
6"	PVC Class 165 (DR 25)	6.31	31	6,723	9,508	5,146	2,623	1,318
6"	PVC Class 235 (DR 18)	6.09	29	8,302	11,740	6,354	3,239	1,627
6"	PVC Class 305 (DR 14)	5.86	27	9,574	13,540	7,328	3,736	1,877
8"	PVC Class 165 (DR 25)	8.28	54	11,577	16,372	8,861	4,517	2,269
8"	PVC Class 235 (DR 18)	7.98	50	14,254	20,158	10,910	5,562	2,794
8"	PVC Class 305 (DR 14)	7.68	46	16,445	23,257	12,587	6,417	3,224
10"	PVC Class 165 (DR 25)	10.16	81	17,431	24,651	13,341	6,801	3,417
10"	PVC Class 235 (DR 18)	9.79	75	21,454	30,340	16,420	8,371	4,206
10"	PVC Class 305 (DR 14)	9.42	70	24,741	34,989	18,936	9,654	4,850
12"	PVC Class 165 (DR 25)	12.08	115	24,641	34,848	18,860	9,615	4,831
12"	PVC Class 235 (DR 18)	11.65	107	30,380	42,964	23,252	11,854	5,956
12"	PVC Class 305 (DR 14)	11.2	99	34,975	49,462	26,768	13,646	6,856
AWWA PVC C-900 PIPE				BASED ON P = 165 + 50 = 215 psi BASED ON P = 235 + 50 = 285 psi BASED ON P = 305 + 50 = 355 psi				

**TABLE 2**

HORIZONTAL BEARING STRENGTHS FOR COMMON SOILS	
SOIL TYPE	HORIZONTAL BEARING STRENGTH (S <sub>b</sub> ), lbs/sf
MUCK	0
SOFT CLAY	500
SAND	1,000
SAND & GRAVEL	1,500
SAND & GRAVEL CEMENTED WITH CLAY	2,000

**NOTES:**

- ALTHOUGH THE ABOVE BEARING STRENGTH VALUES HAVE BEEN USED SUCCESSFULLY IN THE DESIGN OF THRUST BLOCKS AND ARE CONSIDERED TO BE CONSERVATIVE, THEIR ACCURACY IS TOTALLY DEPENDENT ON ACCURATE SOIL IDENTIFICATION AND EVALUATION. THE ULTIMATE RESPONSIBILITY FOR SELECTING THE PROPER BEARING STRENGTH OF A PARTICULAR SOIL TYPE SHALL BE THE RESPONSIBILITY OF THE PROJECT ENGINEER.
- ALL THRUST BLOCK AREAS SHALL BE PROVIDED ON THE APPROVED PLANS.
- CONCRETE THRUST BLOCKS SHALL CONFORM TO STATE STANDARD 90-1.01, 470 LBS/CY CEMENTITIOUS MATERIAL [5 SACK].
- THRUST RESTRAINT FOR VERTICAL BENDS SHALL USE RESTRAINED JOINT FITTINGS INSTEAD OF THRUST BLOCKS.



DEPARTMENT OF PUBLIC WORKS & TRANSPORTATION

**THRUST BLOCK REQUIREMENTS**

Scale:	Adopted:
NTS	2014
Drawing No:	<b>W-1</b>
Sheet No:	1 OF 2



Revisions

Description	Approved	Date	Description	Approved	Date
LEGEND, EQUATIONS, EXAMPLE, SHT 2/2	GDM	JAN 11			

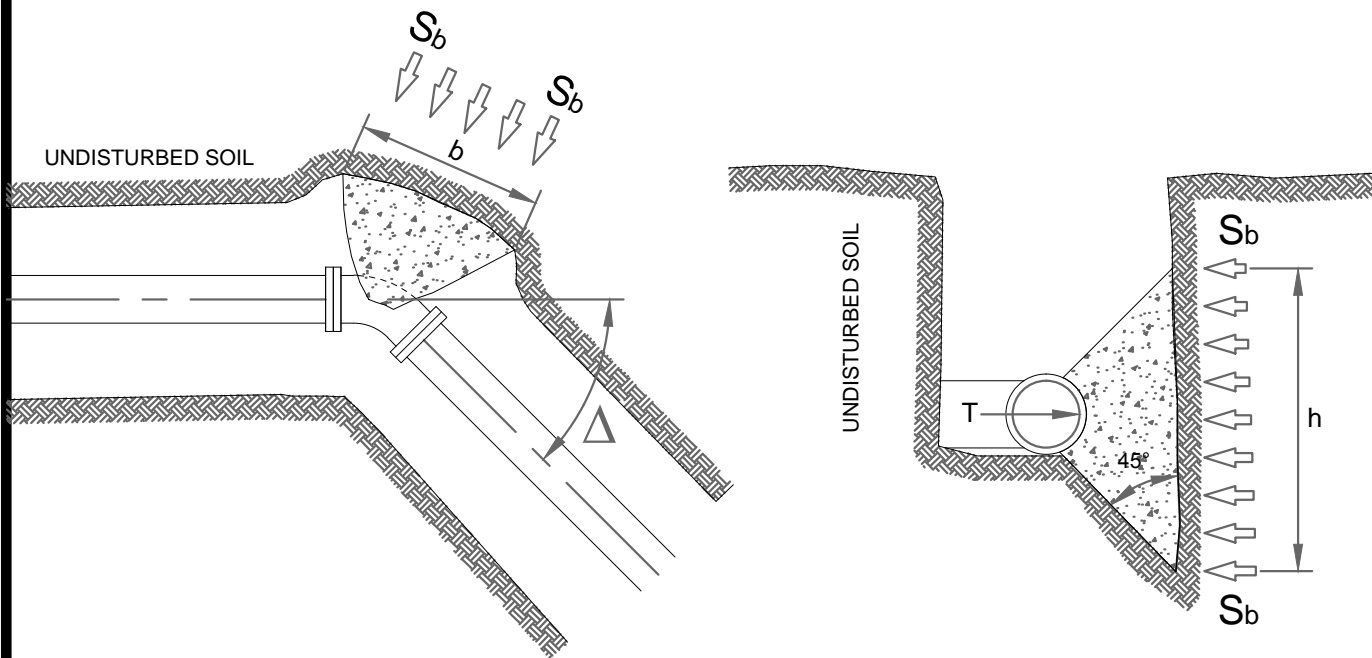

LEGEND:

- T = THRUST AT FITTING (lbs) [TABLE 1]
- $S_b$  = SOIL BEARING PRESSURE (psf) [TABLE 2]
- A = INTERNAL AREA (sq in) [TABLE 1]
- P = INTERNAL PRESSURE (psi)
- $\Delta$  = HORIZONTAL DEFLECTION ANGLE (degrees)
- $S_f$  = FACTOR OF SAFETY [1.5 FOR THRUST BLOCK DESIGN, TYP]
- h = THRUST BLOCK HEIGHT (ft)
- b = THRUST BLOCK WIDTH (ft)
- $A_b$  = MINIMUM THRUST BLOCK AREA (sq ft)

EQUATIONS:

THRUST AT FITTINGS:

[1]  $T = (P)(A)$

THRUST AT HORIZONTAL BEND:

[2]  $T = 2(P)(A) \sin(\Delta/2)$

MINIMUM BEARING (THRUST) BLOCK AREA:

[3]  $A_b = (h)(b) = [(S_f)(T)]/S_b$

EXAMPLE: DETERMINE THE THRUST BLOCK AREA FOR A 90° BEND, 8" CLASS 165 PIPE IN SAND.

(STEP 1): PRESSURE = 165 + 50 (TEST PRESSURE) = 215 psi. CHOOSE T = 16,372 lbs FROM TABLE 1 SHEET 1/2 (USE EQUATION [2] IF PIPE HAS DIFFERENT INSIDE DIAMETER).

(STEP 2): DETERMINE  $S_b$  FROM TABLE 2, SHEET 1/2.

(STEP 3): USE INFORMATION TO CALCULATE  $A_b$  USING EQUATION [3]

RESULT:  $A_b = [S_f(T)]/S_b = [(1.5)(16,372)]/1,000 = 24.6$  sq ft



DEPARTMENT OF PUBLIC WORKS & TRANSPORTATION

THRUST BLOCK REQUIREMENTS

Scale: NTS	Adopted: 2014
Drawing No: <b>W-1a</b>	
Sheet No: 2 OF 2	

Revisions

Description	Approved	Date	Description	Approved	Date
NOTE 4	REM	NOV 07	CLARIFIED MJ CONNECTIONS, NOTE 2	GDM	JAN 11
NOTE 8 (FROM CLOW F2060 TO CLOW F960)	GDM	NOV 08			

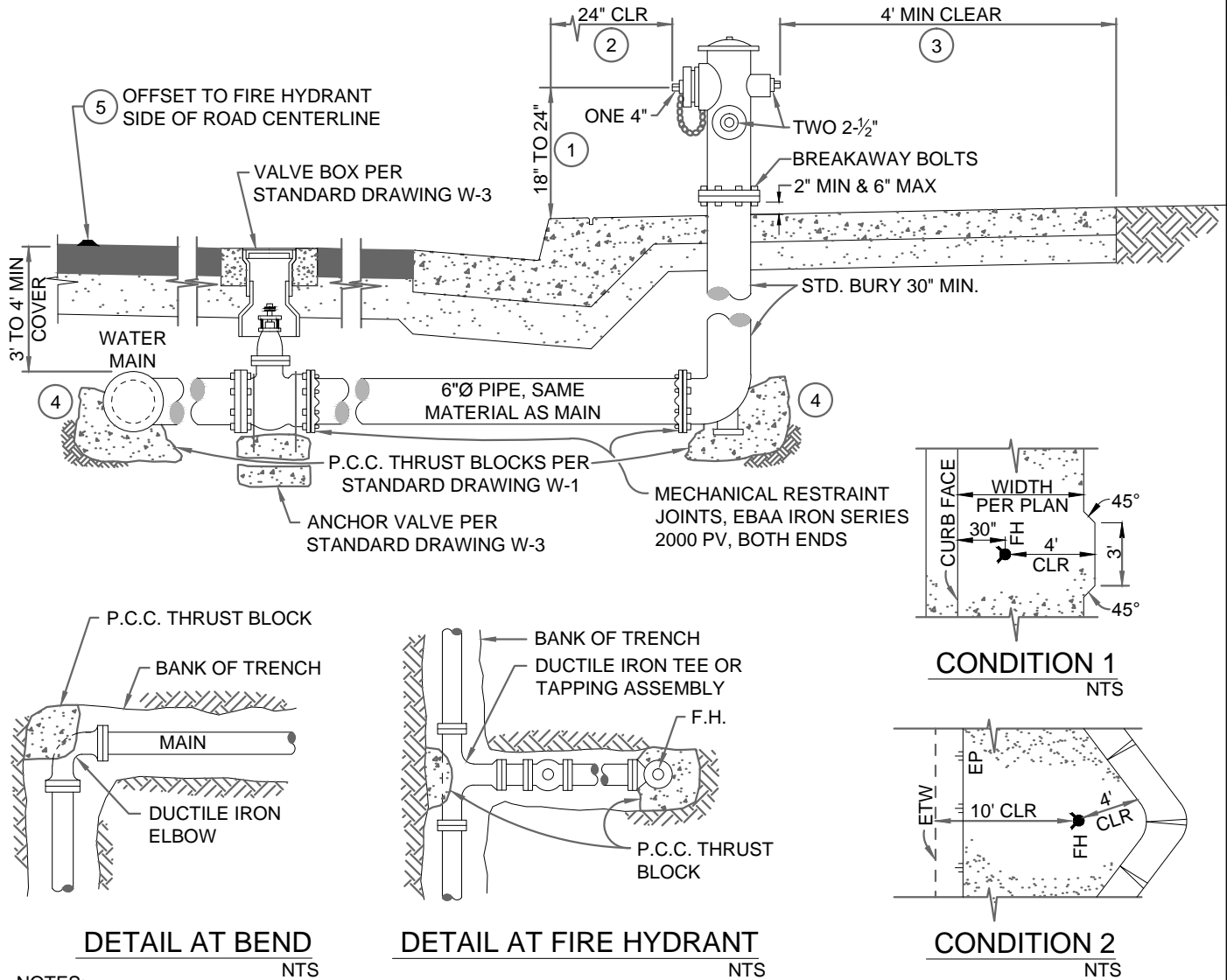

- NOTES:
- HEIGHT SHALL BE MEASURED FROM EDGE OF PAVEMENT WHEN CONCRETE CURB OR ASPHALT DIKE ARE NOT REQUIRED PER THE DESIGN STANDARDS.
  - DISTANCE SHALL BE INCREASED TO 10-FOOT CLEAR FROM THE EDGE OF TRAVELED WAY (ETW) ON RURAL ROADS (SEE U-1).
  - IN RURAL AREAS A 4' MINIMUM RADIUS CLEAR AND LEVEL ZONE SURROUNDING THE FIRE HYDRANT SHALL BE REQUIRED.
  - CONCRETE THRUST BLOCKS SHALL CONFORM TO STATE STANDARD 90-1.01, 470 LBS/CY CEMENTITIOUS MATERIAL [5 SACK], POURED AGAINST UNDISTURBED SOIL AND SHIELDED FROM FLANGES AND BOLTS.
  - EACH HYDRANT SHALL BE IDENTIFIED BY A REFLECTORIZED BLUE RAISED PAVEMENT MARKER PER SECTION 10.301c OF THE UNIFORM FIRE CODE.
  - THE HYDRANT CAP AND OUTLET NOZZLE SHALL BE PAINTED IN ACCORDANCE WITH TABLE 6.6 OF 6.2.1.D.2.
  - THE CONCRETE CURB OR ASPHALT DIKE SHALL BE PAINTED RED 15-FOET EITHER SIDE OF THE FIRE HYDRANT.
  - HYDRANT SHALL BE CLOW F960, OR APPROVED EQUAL.
  - EACH HYDRANT SHALL HAVE TWO 2-1/2" OUTLETS AND ONE 4" OUTLET WITH EXTERNAL NSF THREAD.
  - ALL FITTINGS SHALL BE CEMENT MORTAR LINED IN ACCORDANCE WITH AWWA STANDARD C-104.
  - HYDRANT LATERAL SHALL BE OF THE SAME MATERIAL AS THE MAIN.
  - 14-GAUGE INSULATED COPPER TRACER WIRE SHALL BE LAID IN THE TRENCH ABOVE THE PIPE, BROUGHT ABOVE GRADE AND SECURED TO THE HYDRANT BOLT FLANGE.
  - COLOR CODED BLUE 3" WIDE POLYETHYLENE NON-DETECTABLE TAPE MARKED "CAUTION BURIED WATER LINE BELOW" SHALL BE BURIED IN THE TRENCH AND ABOVE THE PIPE AND TRACER WIRE.



DEPARTMENT OF PUBLIC WORKS & TRANSPORTATION  
**FIRE HYDRANT INSTALLATION**

Scale: 1"=2'	Adopted: 2014
Drawing No: <b>W-2</b>	
Sheet No: 1 OF 1	

Revisions

Description	Approved	Date	Description	Approved	Date
NOTE 1, CONCRETE COLLAR NOTE	REM	NOV 07			

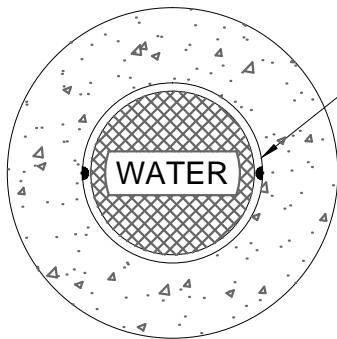

LID

10" MIN THICK BEARING CONCRETE COLLAR SHALL CONFORM TO STATE STANDARD 90-1.01, 565 LBS/CY CEMENTITIOUS MATERIAL [6 SACK], TROWELLED TO FINISHED GRADE, AND ALLOWED TO CURE 48 HOURS PRIOR TO FULL TRAFFIC USE.

VALVE BOX - BROOKS No. 3RT OR APPROVED EQUAL WITH EXTENSIONS TO VALVE

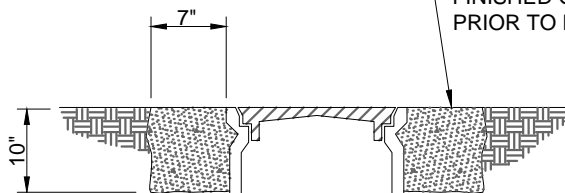

ANCHOR STRAPS EACH SIDE

TRENCH BOTTOM

VALVE ANCHOR SHALL BE POURED LEVEL WITH TRENCH BOTTOM ANCHOR STRAPS SHALL BE FASTENED TO CONCRETE EMBEDDED ANCHOR BOLTS

P.C.C. BLOCK IS HUB-TO-HUB WIDTH

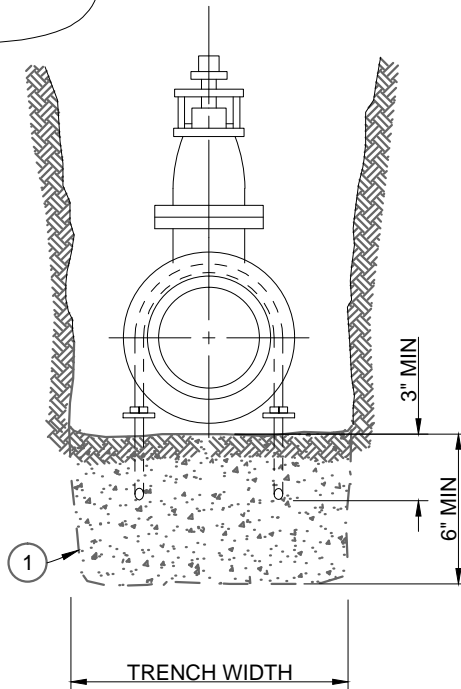
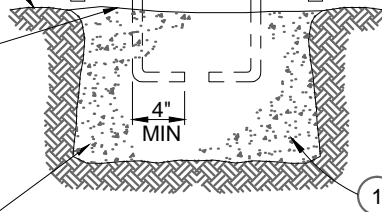

NOTES:

1. CONCRETE THRUST BLOCKS SHALL CONFORM TO STATE STANDARD 90-1.01, 470 LBS/CY CEMENTITIOUS MATERIAL [5 SACK], AND POURED AGAINST UNDISTURBED NATIVE SOIL.
2. VALVES SHALL HAVE NON-RISING STEM, RESILIENT WEDGE, RESILIENT SEAT, AND BE EPOXY COATED.
3. ALL MATERIALS AND INSTALLATION SHALL CONFORM WITH THE APPLICABLE SECTIONS OF THE DESIGN STANDARDS.
4. ALL FITTINGS SHALL BE WRAPPED IN POLYETHYLENE SHEET AND ALL FLANGES AND BOLTS SHALL BE SHIELDED FROM CONCRETE PER THE DESIGN STANDARDS.
5. UNDER NO CIRCUMSTANCES SHALL UTILITY LIDS AND CONCRETE COLLARS BE LOCATED WITHIN CURBS, GUTTERS, SIDEWALKS, DRIVEWAY APRONS, CURB RAMPS, OR CROSS GUTTERS.



DEPARTMENT OF PUBLIC WORKS & TRANSPORTATION

VALVE ANCHOR & BOX

Scale: NTS	Adopted: 2014
Drawing No:	<b>W-3</b>
Sheet No:	1 OF 1

Revisions

Description	Approved	Date	Description	Approved	Date

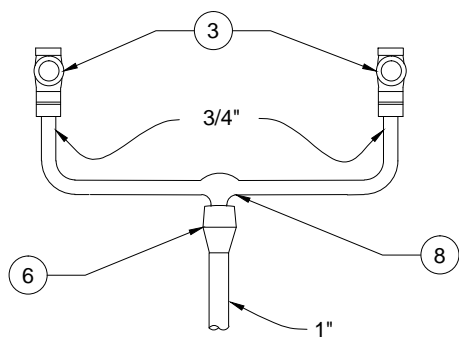
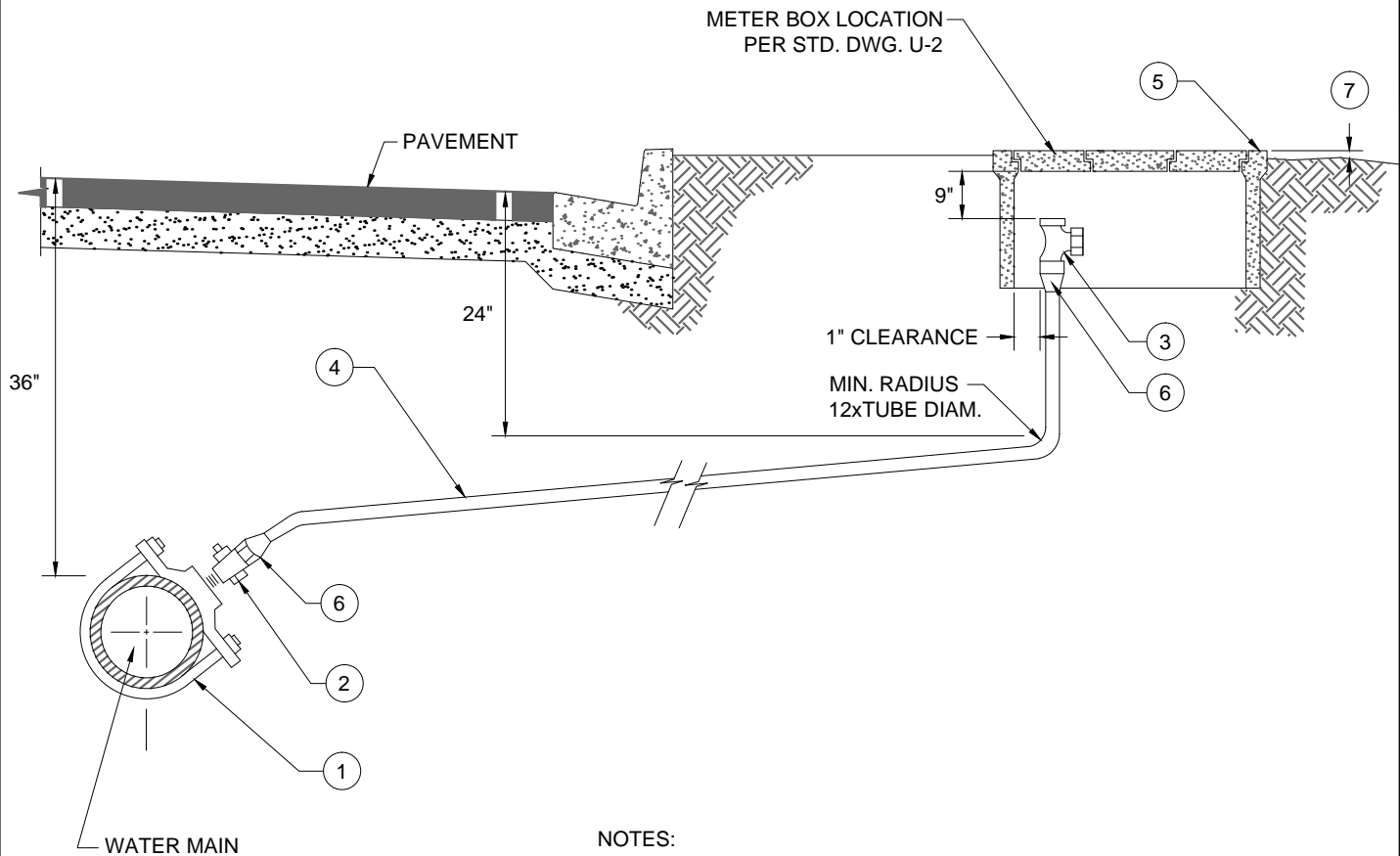

**DOUBLE SERVICE CONNECTION**

NOTES:

- BRONZE SERVICE SADDLE, DOUBLE STRAP, MUELLER BR 2B 0899 IP, 075 or 100, O.A.E.
- CORPORATION STOP w/ IP THREADS, MUELLER H-10012, O.A.E.
- ANGLE METER STOP, JONES J-1966W, 3/4" or 1", O.A.E.
- POLYETHYLENE PIPE, 3/4" MIN. I.D. FOR SINGLE SERVICE 1" MIN. I.D. FOR DOUBLE SERVICE.
- METER BOX, BROOKS PRODUCT 37-S, O.A.E.
- MUELLER INSTA-TITE CONNECTION H-15426(male) O.A.E. H-15456 (female).
- IN UNPAVED AREA SET METER BOX 1" to 1-1/2" ABOVE FINISHED GRADE.
- U-BRANCH CONNECTION, MUELLER H-15365, O.A.E.
- O.A.E. = "OR APPROVED EQUAL".
- WATER METER AND CUSTOMER SIDE SHUT OFF VALVE TO BE INSTALLED BY THE WATER PURVEYOR.
- CORPORATION STOPS SHALL NOT BE SPACED CLOSER THAN 12" MEASURED ALONG THE CENTERLINE OF THE PIPE.
- 3/4" SINGLE SERVICE LINE, 1" DOUBLE SERVICE LINES, USE 16" X 21" DUAL METER BOX (BROOKS PRODUCT OR APPROVED EQUAL) FOR DOUBLE SERVICE.
- SERVICES LARGER THAN 1" MAY BE PVC SCHEDULE 80 PIPE.
- 14-GAUGE INSULATED COPPER TRACER WIRE SHALL BE LAID IN THE TRENCH ABOVE THE PIPE AND BROUGHT ABOVE GRADE THROUGH ANY METER OR VALVE BOXES.
- COLOR CODED BLUE 3" WIDE POLYETHYLENE NON-DETECTABLE TAPE MARKED "CAUTION BURIED WATER LINE BELOW" SHALL BE BURIED IN THE TRENCH AND ABOVE THE PIPE AND TRACER WIRE.



DEPARTMENT OF PUBLIC WORKS & TRANSPORTATION

**WATER SERVICE CONNECTION**

Scale: NTS	Adopted: 2014
Drawing No:	<b>W-4</b>
Sheet No:	<b>1 OF 1</b>

Revisions

Description	Approved	Date	Description	Approved	Date

NOTES:

1. DIRECT CONNECTION TO THE EXISTING WATER SYSTEM SHALL NOT BE PERMITTED UNTIL THE NEW INSTALLATION HAS PASSED BACTERIA TESTING AND A PHYSICAL CHECK BY THE WATER QUALITY MANAGER. SEPARATION SHALL BE ACHIEVED BY THE INSTALLATION OF THE TEMPORARY BLOCKING DEVICE AS SHOWN HEREON
2. PRESSURE TESTING AGAINST VALVES SHALL NOT BE ALLOWED. NEW VALVES SHALL BE SWABBED WITH CHLORINE PRIOR TO INSTALLATION.
3. WHEN TEMPORARY BLOCKING DEVICE IS REMOVED, THE CONTRACTOR SHALL ADJUST FITTING TO ELIMINATE 1/8" GAP WITHOUT FORCING THE JOINT TOGETHER.
4. TEST PRESSURE SHALL BE 50 PSI GREATER THAN THE WORKING PRESSURE OF THE PIPE MEASURED AT THE LOWEST ELEVATION OF THE SYSTEM OR 150 PSI, WHICHEVER IS GREATER.

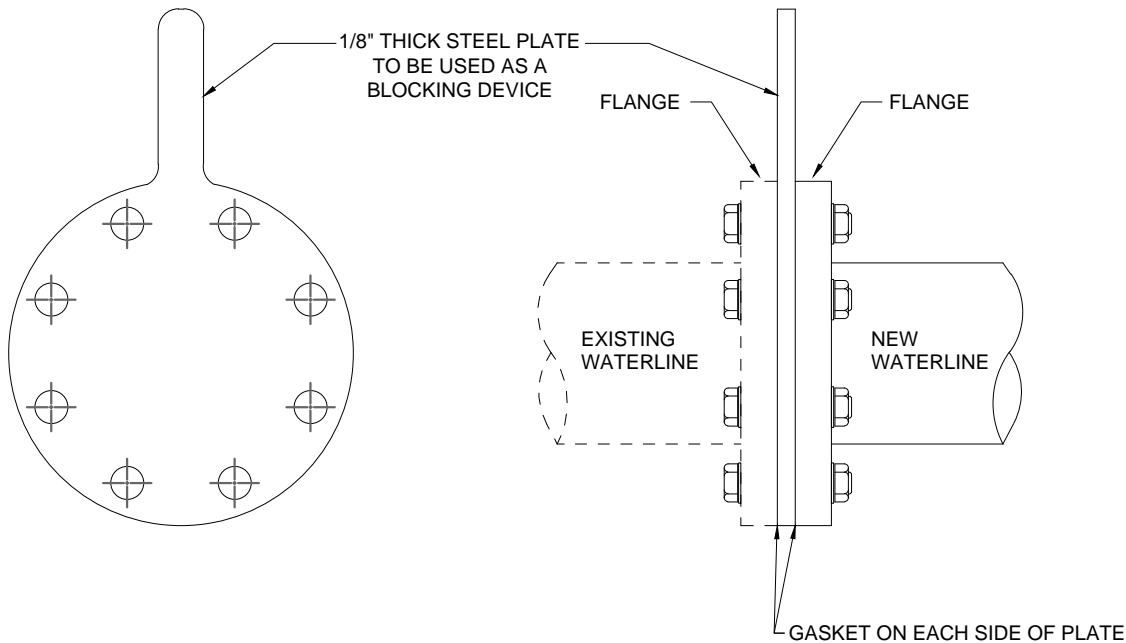
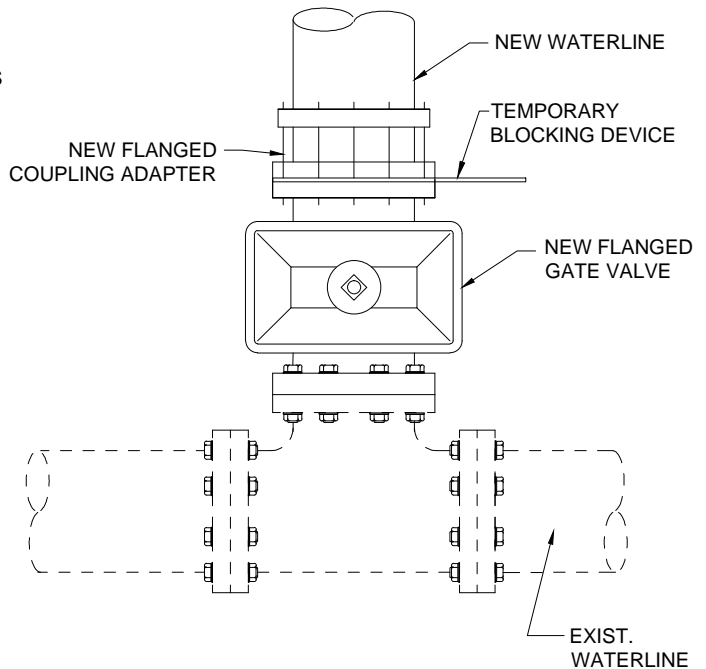

PROCEDURE FOR CONNECTING NEW WATERLINES TO EXISTING SYSTEM (ALTERNATIVE TO THE OLD INDUSTRIAL STANDARD METHOD): AT THE POINT OF CONNECTION TO THE EXISTING SYSTEM, ALL JOINTS BETWEEN FITTINGS AND VALVES SHALL BE FLANGED. ANY CHANGE REQUIRES WRITTEN APPROVAL FROM THE DEPARTMENT. AT THE JOINT THAT CONNECTS THE EXISTING SYSTEM TO THE NEW LINE, A BLOCKING DEVICE SHALL BE INSTALLED. THIS DEVICE SHALL BE CONSTRUCTED OF 1/8" THICK STEEL PLATE. IT SHALL BE INSTALLED BETWEEN THE TWO FLANGES WITH A GASKET ON EACH SIDE. THIS WILL ALLOW ALL FITTINGS, VALVES, AND THE PIPELINE TO BE DISINFECTED AND PRESSURE TESTED AS ONE UNIT. AFTER THE NEW SYSTEM HAS MET ALL REQUIREMENTS, THE DEPARTMENT WILL ALLOW THE CONTRACTOR TO REMOVE THE BLOCKING DEVICE. THE DEVICE AND BOTH GASKETS ARE TO BE REMOVED AND A NEW GASKET SHALL BE INSTALLED BETWEEN THE FLANGES. THE NEW SYSTEM IS THEN IN SERVICE.



DEPARTMENT OF PUBLIC WORKS & TRANSPORTATION  
**NEW WATERLINE  
 CONNECTION DETAILS**

Scale:	Adopted:
NTS	2014
Drawing No:	<b>W-8</b>
Sheet No:	1 OF 1

Revisions

Description	Approved	Date	Description	Approved	Date
THRUST BLOCK NOTES	REM	NOV 07			

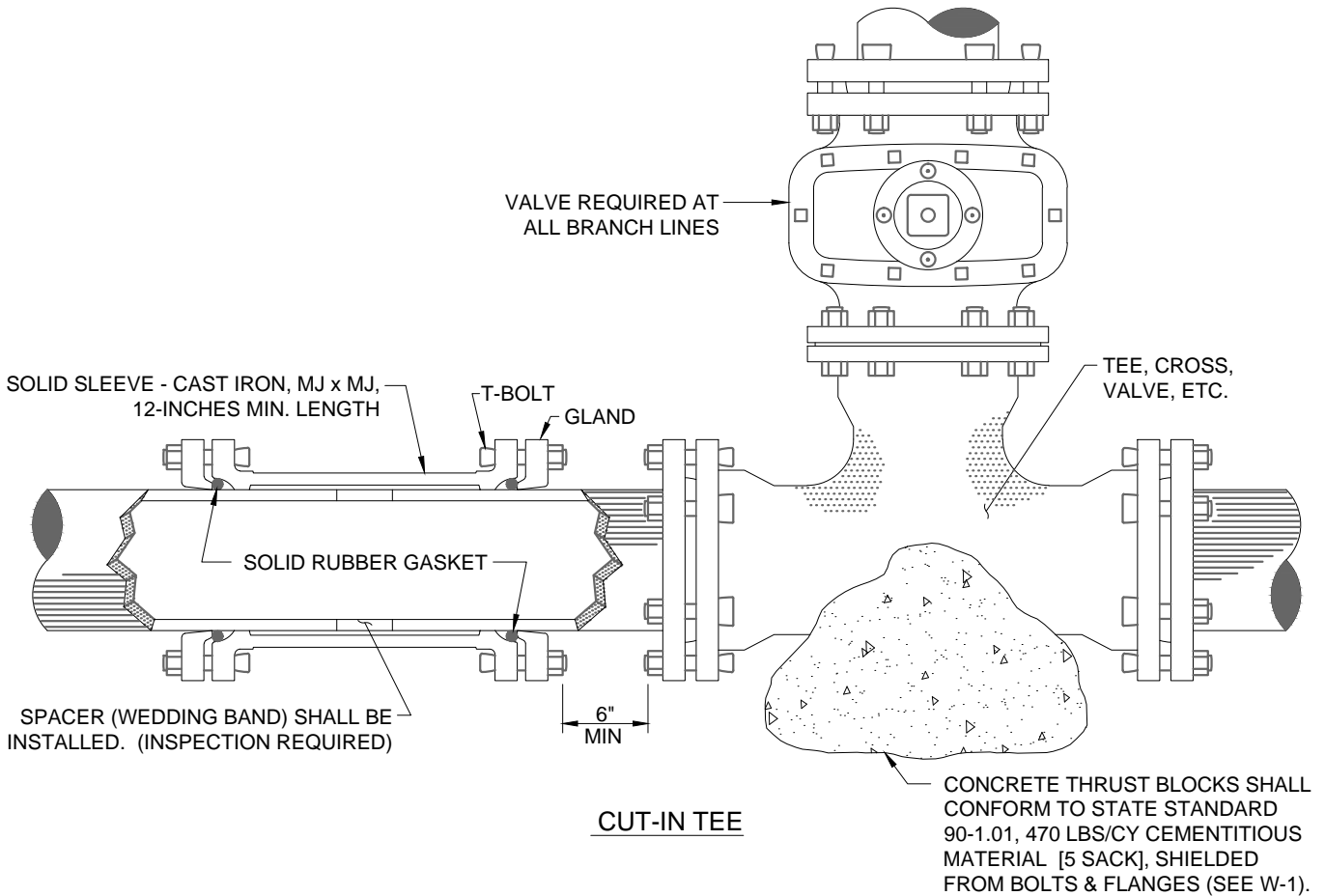

TAPPING VALVE - GATE VALVE, RESILIENT SEATED WITH FULLY ENCAPSULATED GATE, EPOXY-COATED INSIDE AND OUTSIDE, FULL-SIZE WATERWAY, OPEN TO THE LEFT, NON- RISING STEM WITH O-RING SEALS, 200 PSI WORKING PRESSURE, AND MEETS AWWA C-509. AVK, CLOW F-1600 OR APPROVED EQUAL.

TAPPING SLEEVE SHALL BE SEPARATED FROM NEAREST BELL, FLANGE, SERVICE CLAMP, CORP STOP, ETC. BY A DISTANCE NO LESS THAN 1 1/2 PIPE DIAMETERS, WITH A MINIMUM OF 18-INCHES.

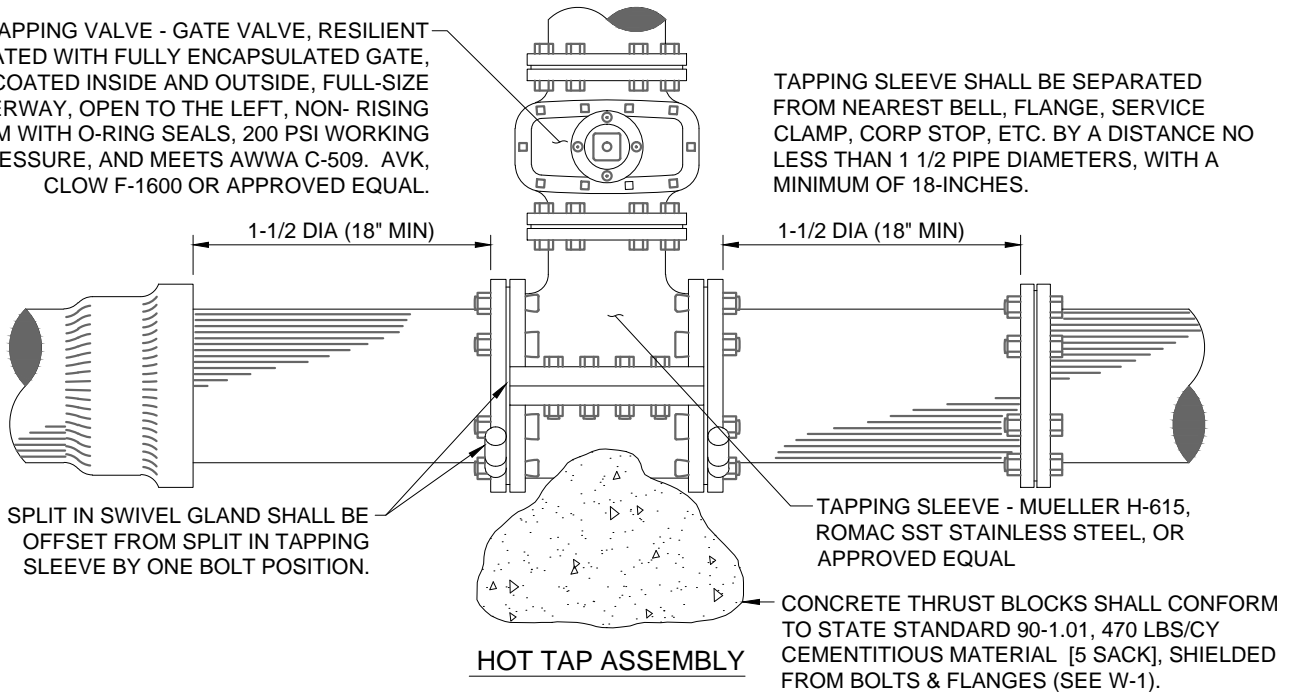

DEPARTMENT OF PUBLIC WORKS & TRANSPORTATION  
**WATERLINE CUT-IN TEE  
 & HOT TAP ASSEMBLY**

Scale: NTS	Adopted: 2014
Drawing No: <b>W-10</b>	
Sheet No:	1 OF 1

**OCEANO COMMUNITY SERVICES DISTRICT**  
**NORSWING/PERSHING WATERLINE REPLACEMENT PROJECT**  
**INSURANCE REQUIREMENTS**  
**FOR**  
**OCEANO, CA**  
**CONTRACT NO. 2019-03**

**OCEANO COMMUNITY SERVICES DISTRICT**

**Norswing / Pershing Waterline Replacement Project**

**OCEANO, CA  
CONTRACT NO. 2019-03**

**INSURANCE REQUIREMENTS**



# INSURANCE REQUIREMENTS

## INDEMNIFICATION

To the fullest extent permitted by law, CONTRACTOR shall indemnify, defend and hold harmless the District and its officers, agents, employees, and volunteers from and against all claims, demands, damages, liabilities, loss, costs, and expense (including attorney's fees and costs of litigation) of every nature arising out of or in connection with Contractor's performance or attempted performance of work hereunder or its failure to comply with any of its obligations contained in the agreement, except such loss or damage which was caused by sole negligence or willful misconduct of the District.

## INSURANCE COVERAGE

Contractor shall procure and maintain for the duration of the contract insurance against claims for injuries to persons or damages to property which may arise from or in connection with the performance of the work hereunder by the Contractor, its agents, representatives, or employees.

## MINIMUM SCOPE AND LIMIT OF INSURANCE

Coverage shall be at least as broad as:

1. Commercial General Liability (CGL); Insurance Services Office (ISO) Form CG 0001 covering CGL on an "occurrence" basis for bodily injury and property damage, including products-completed, operations, personal injury and advertising injury, with limits no less than \$1,000,000 per occurrence. If a general aggregate limit applies either the general aggregate limit shall apply separately to this project/location or the general aggregate limit shall be twice the required occurrence limit.
2. Automobile Liability: ISO Form Number CA 0001 covering, Code 1 (any auto), or if Contractor has no owned autos, Code 8 (hired) and 9 (non-owned), with limit no less than \$1,000,000 per accident for bodily injury and property damages.
3. Worker Compensation insurance as required by the State of California, with Statutory Limits, and Employer's Liability insurance with limit of no less than \$1,000,000 per accident for bodily injury or disease. If Contractor will provide leased employees, or is an employee leasing or temporary staffing firm or a professional employer organization (PEO), coverage shall also include an Alternate Employer Endorsement (providing scope of coverage equivalent to ISO policy form WC 00 03 O1 A) naming the District as the Alternate Employer, and the endorsement form shall be modified to provide that District will receive not less than thirty (30) days advance written notice of cancellation of this coverage provision. If applicable to Contractor's operations, coverage also shall be arranged to satisfy the requirements of any federal workers or workmen's compensation law or any federal occupational disease law.  
*(Not required if Contractor provides written verification it has no employees)*

If the contractor maintains higher limits than the minimums shown above, the District requires and shall be entitled to coverage for the higher limits maintained by the contractor.

### **OTHER INSURANCE PROVISIONS**

The insurance policies are to contain, or be endorsed to contain, the following provisions:

#### *Additional Insured Status:*

The District, its officers, officials, employees, and volunteers are to be covered as insureds on the auto policy with respect to liability arising out of automobiles owned, leased, hired or borrowed by, or on behalf of the Contractor; and on the CGL policy with respect to liability arising out of work or operations performed by or on behalf of the Contractor including materials, parts, or equipment furnished in connection with such work or operations. General liability coverage can be provided in the form of an endorsement to the Contractor's insurance (at least as broad as ISO Form CG 20 10, 11 85 or both CG 20 10 and CG 23 37 forms if later revisions used).

#### *Primary Coverage*

For any claims related to this contract, the Contractor's insurance coverage shall be primary insurance as respects the District, its officers, officials, employees, and volunteers. Any insurance of self-insurance maintained by the District, its officers, officials, employees, or volunteers shall be excess of the Contractor's insurance and shall not contribute with it.

#### *Notice of Cancellation*

Each insurance policy required above shall state that coverage shall not be canceled, except after thirty (30) days prior written notice (10 days for non-payment) has been given to the District.

#### *Failure to Maintain Insurance*

Contractor's failure to maintain or to provide acceptable evidence that it maintains the required insurance shall constitute a material breach of the Contract upon which the District immediately may withhold payments due to Contractor, and/or suspend or terminate this Contract. The District, at its sole discretion, may obtain damages from Contractor resulting from said breach.

#### *Waiver of Subrogation*

Contractor hereby grants to District a waiver of any right to subrogation which any insurer of said Contractor may acquire against the District by virtue of the payment of any loss under such insurance. Contractor agrees to obtain any endorsement that may be necessary to affect this waiver of subrogation, but this provision applies regardless of whether or not the District has received a waiver of subrogation endorsement from the insurer.

#### *Deductibles and Self-Insured Retentions*

Any deductibles or self-insured retentions must be declared to and approved by the District. The District may require the Contractor to provide proof of ability to pay losses and related investigation, claim administration, and defense expenses within the retention.

#### *Acceptability of Insurers*

Insurance is to be placed with insurers with a current A.A. Best's rating of no less than A:VII, unless otherwise acceptable to the District.

### *Claims Made Policies*

If any of the required policies provide coverage on a claims-made basis:

1. The Retroactive Date must be shown and must be before the date of the contract or the beginning of contract work;
2. Insurance must be maintained and evidence of insurance must be provided for at least five (5) years after completion of the contract of work;
3. If coverage is canceled or non-renewed, and not replaced with another claims-made policy form with a Retroactive date prior to the contract effective date, the Contractor must purchase "extended reporting" coverage for a minimum of five (5) years.

### *Separation of Insured's*

All liability policies shall provide cross-liability coverage as would be afforded by the standard ISO (Insurance Services Office, Inc.) separate of insured's provision with no insured versus insured exclusions or limitation.

### *Verification of Coverage*

Contractor shall furnish the District with original certificates and mandatory endorsements or copies of the applicable policy language effecting coverage required by this clause. All certificates and endorsements are to be received and approved by the District before work commences. However, failure to obtain the required documents prior to the work beginning shall not waive the Contractor's obligation to provide them. The District reserves the right to required complete, certified copies of all required insurance policies, including endorsements required by these specifications, at any time.

Certificates and copies of any required endorsements shall be sent to:

Oceano Community Services District  
P.O. Box 599  
Oceano, CA 93475-0599

### *Subcontractors*

Contractor shall require and verify that all subcontractors maintain insurance meeting all the requirements stated herein.

### *Special Risks or Circumstances*

District reserves the right to modify these requirements, including limits, based on the nature of the risk, prior experience, insurer, coverage, or other special circumstances.

**OCEANO COMMUNITY SERVICES DISTRICT**  
**NORSWING/PERSHING WATERLINE REPLACEMENT PROJECT**  
**PERFORMANCE AND PAYMENT BONDS**  
**FOR**  
**OCEANO, CA**  
**CONTRACT NO. 2019-03**

(x) Performance and Payment Bonds

**PERFORMANCE BOND**

CONTRACTOR (*Name and Address*):

SURETY (*Name, and Address of Principal Place of Business*):

OWNER (*Name and Address*):

Oceano Community Services District  
1655 Front Street  
Oceano, CA 93445  
Attention: General Manager

CONSTRUCTION CONTRACT

Effective Date of Agreement:

Amount:

Description: Norswing / Pershing Waterline Replacement Project, Oceano, Ca, Contract No. 2019-03

BOND

Bond Number:

Date (*Not earlier than Effective Date of Agreement of the Construction Contract*):

Amount:

Modifications to this Bond Form:       None       See Paragraph 16

Surety and Contractor, intending to be legally bound hereby, subject to the terms set forth below, do each cause this Performance Bond to be duly executed by an authorized officer, agent, or representative.

**CONTRACTOR AS PRINCIPAL**

**SURETY**

\_\_\_\_\_  
(Seal)  
Contractor's Name and Corporate Seal

\_\_\_\_\_  
(Seal)  
Surety's Name and Corporate Seal

By: \_\_\_\_\_  
Signature

By: \_\_\_\_\_  
Signature (Attach Power of Attorney)

\_\_\_\_\_  
Print Name

\_\_\_\_\_  
Print Name

\_\_\_\_\_  
Title

\_\_\_\_\_  
Title

Attest: \_\_\_\_\_  
Signature

Attest: \_\_\_\_\_  
Signature

\_\_\_\_\_  
Title

\_\_\_\_\_  
Title

*Notes: (1) Provide supplemental execution by any additional parties, such as joint venturers, (2) Any singular reference to Contractor, Surety, Owner, or other party shall be considered plural where applicable.*

1. The Contractor and Surety, jointly and severally, bind themselves, their heirs, executors, administrators, successors, and assigns to the Owner for the performance of the Construction Contract, which is incorporated herein by reference.
2. If the Contractor performs the Construction Contract, the Surety and the Contractor shall have no obligation under this Bond, except when applicable to participate in a conference as provided in Paragraph 3.
3. If there is no Owner Default under the Construction Contract, the Surety's obligation under this Bond shall arise after:
  - 3.1 The Owner first provides notice to the Contractor and the Surety that the Owner is considering declaring a Contractor Default. Such notice shall indicate whether the Owner is requesting a conference among the Owner, Contractor, and Surety to discuss the Contractor's performance. If the Owner does not request a conference, the Surety may, within five (5) business days after receipt of the Owner's notice, request such a conference. If the Surety timely requests a conference, the Owner shall attend. Unless the Owner agrees otherwise, any conference requested under this Paragraph 3.1 shall be held within ten (10) business days of the Surety's receipt of the Owner's notice. If the Owner, the Contractor, and the Surety agree, the Contractor shall be allowed a reasonable time to perform the Construction Contract, but such an agreement shall not waive the Owner's right, if any, subsequently to declare a Contractor Default;
  - 3.2 The Owner declares a Contractor Default, terminates the Construction Contract and notifies the Surety; and
  - 3.3 The Owner has agreed to pay the Balance of the Contract Price in accordance with the terms of the Construction Contract to the Surety or to a contractor selected to perform the Construction Contract.
4. Failure on the part of the Owner to comply with the notice requirement in Paragraph 3.1 shall not constitute a failure to comply with a condition precedent to the Surety's obligations, or release the Surety from its obligations, except to the extent the Surety demonstrates actual prejudice.
5. When the Owner has satisfied the conditions of Paragraph 3, the Surety shall promptly and at the Surety's expense take one of the following actions:
  - 5.1 Arrange for the Contractor, with the consent of the Owner, to perform and complete the Construction Contract;
  - 5.2 Undertake to perform and complete the Construction Contract itself, through its agents or independent contractors;
  - 5.3 Obtain bids or negotiated proposals from qualified contractors acceptable to the Owner for a contract for performance and completion of the Construction Contract, arrange for a contract to be prepared for execution by the Owner and a contractor selected with the Owners concurrence, to be secured with performance and payment bonds executed by a qualified surety equivalent to the bonds issued on the Construction Contract, and pay to the Owner the amount of damages as described in Paragraph 7 in excess of the Balance of the Contract Price incurred by the Owner as a result of the Contractor Default; or
  - 5.4 Waive its right to perform and complete, arrange for completion, or obtain a new contractor, and with reasonable promptness under the circumstances:
    - 5.4.1 After investigation, determine the amount for which it may be liable to the Owner and, as soon as practicable after the amount is determined, make payment to the Owner; or
    - 5.4.2 Deny liability in whole or in part and notify the Owner, citing the reasons for denial.
6. If the Surety does not proceed as provided in Paragraph 5 with reasonable promptness, the Surety shall be deemed to be in default on this Bond seven days after receipt of an additional written notice from the

Owner to the Surety demanding that the Surety perform its obligations under this Bond, and the Owner shall be entitled to enforce any remedy available to the Owner. If the Surety proceeds as provided in Paragraph 5.4, and the Owner refuses the payment, or the Surety has denied liability, in whole or in part, without further notice the Owner shall be entitled to enforce any remedy available to the Owner.

7. If the Surety elects to act under Paragraph 5.1, 5.2, or 5.3, then the responsibilities of the Surety to the Owner shall not be greater than those of the Contractor under the Construction Contract, and the responsibilities of the Owner to the Surety shall not be greater than those of the Owner under the Construction Contract. Subject to the commitment by the Owner to pay the Balance of the Contract Price, the Surety is obligated, without duplication for:
  - 7.1 the responsibilities of the Contractor for correction of defective work and completion of the Construction Contract;
  - 7.2 additional legal, design professional, and delay costs resulting from the Contractor's Default, and resulting from the actions or failure to act of the Surety under Paragraph 5; and
  - 7.3 liquidated damages, or if no liquidated damages are specified in the Construction Contract, actual damages caused by delayed performance or non-performance of the Contractor.
8. If the Surety elects to act under Paragraph 5.1, 5.3, or 5.4, the Surety's liability is limited to the amount of this Bond.
9. The Surety shall not be liable to the Owner or others for obligations of the Contractor that are unrelated to the Construction Contract, and the Balance of the Contract Price shall not be reduced or set off on account of any such unrelated obligations. No right of action shall accrue on this Bond to any person or entity other than the Owner or its heirs, executors, administrators, successors, and assigns.
10. The Surety hereby waives notice of any change, including changes of time, to the Construction Contract or to related subcontracts, purchase orders, and other obligations.
11. Any proceeding, legal or equitable, under this Bond may be instituted in any court of competent jurisdiction in the location in which the work or part of the work is located and shall be instituted within two years after a declaration of Contractor Default or within two years after the Contractor ceased working or within two years after the Surety refuses or fails to perform its obligations under this Bond, whichever occurs first. If the provisions of this paragraph are void or prohibited by law, the minimum periods of limitations available to sureties as a defense in the jurisdiction of the suit shall be applicable.
12. Notice to the Surety, the Owner, or the Contractor shall be mailed or delivered to the address shown on the page on which their signature appears.
13. When this Bond has been furnished to comply with a statutory or other legal requirement in the location where the construction was to be performed, any provision in this Bond conflicting with said statutory or legal requirement shall be deemed deleted here from and provisions conforming to such statutory or other legal requirement shall be deemed incorporated herein. When so furnished, the intent is that this Bond shall be construed as a statutory bond and not as a common law bond.
14. Definitions
  - 14.1 Balance of the Contract Price: The total amount payable by the Owner to the Contractor under the Construction Contract after all proper adjustments have been made including allowance for the Contractor for any amounts received or to be received by the Owner in settlement of insurance or other claims for damages to which the Contractor is entitled, reduced by all valid and proper payments made to or on behalf of the Contractor under the Construction Contract.
  - 14.2 Construction Contract: The agreement between the Owner and Contractor identified on the cover page, including all Contract Documents and changes made to the agreement and the Contract Documents.

- 14.3 Contractor Default: Failure of the Contractor, which has not been remedied or waived, to perform or otherwise to comply with a material term of the Construction Contract.
- 14.4 Owner Default: Failure of the Owner, which has not been remedied or waived, to pay the Contractor as required under the Construction Contract or to perform and complete or comply with the other material terms of the Construction Contract.
- 14.5 Contract Documents: All the documents that comprise the agreement between the Owner and Contractor.
15. If this Bond is issued for an agreement between a contractor and subcontractor, the term Contractor in this Bond shall be deemed to be Subcontractor and the term Owner shall be deemed to be Contractor.
16. Modifications to this Bond are as follows:
17. The effective date of this Bond shall be the same date as the Effective Date of the Construction Contract.

**END OF SECTION**



**PAYMENT BOND**

CONTRACTOR (*Name and Address*):

SURETY (*Name, and Address of Principal Place of Business*):

OWNER (*Name and Address*):

Oceano Community Services District  
1655 Front Street  
Oceano, CA 93445  
Attention: General Manager

**CONSTRUCTION CONTRACT**

Effective Date of Agreement:

Amount:

Description: Norswing / Pershing Waterline Replacement Project, Oceano, Ca, Contract No. 2019-03

**BOND**

Bond Number:

Date (*Not earlier than Effective Date of Agreement of the Construction Contract*):

Amount:

Modifications to this Bond Form:       None       See Paragraph 18

Surety and Contractor, intending to be legally bound hereby, subject to the terms set forth below, do each cause this Performance Bond to be duly executed by an authorized officer, agent, or representative.

**CONTRACTOR AS PRINCIPAL**

**SURETY**

\_\_\_\_\_  
(Seal)  
Contractor's Name and Corporate Seal

\_\_\_\_\_  
(Seal)  
Surety's Name and Corporate Seal

By: \_\_\_\_\_  
Signature

By: \_\_\_\_\_  
Signature (Attach Power of Attorney)

\_\_\_\_\_  
Print Name

\_\_\_\_\_  
Print Name

\_\_\_\_\_  
Title

\_\_\_\_\_  
Title

Attest: \_\_\_\_\_  
Signature

Attest: \_\_\_\_\_  
Signature

\_\_\_\_\_  
Title

\_\_\_\_\_  
Title

Notes: (1) Provide supplemental execution by any additional parties, such as joint venturers, (2) Any singular reference to Contractor, Surety, Owner, or other party shall be considered plural where applicable.

1. The Contractor and Surety, jointly and severally, bind themselves, their heirs, executors, administrators, successors, and assigns to the Owner to pay for labor, materials, and equipment furnished for use in the performance of the Construction Contract, which is incorporated herein by reference, subject to the following terms.
2. If the Contractor promptly makes payment of all sums due to Claimants, and defends, indemnifies, and holds harmless the Owner from claims, demands, liens, or suits by any person or entity seeking payment for labor, materials, or equipment furnished for use in the performance of the Construction Contract, then the Surety and the Contractor shall have no obligation under this Bond.
3. If there is no Owner Default under the Construction Contract, the Surety's obligation to the Owner under this Bond shall arise after the Owner has promptly notified the Contractor and the Surety (at the address described in Paragraph 13) of claims, demands, liens, or suits against the Owner or the Owner's property by any person or entity seeking payment for labor, materials, or equipment furnished for use in the performance of the Construction Contract, and tendered defense of such claims, demands, liens, or suits to the Contractor and the Surety.
4. When the Owner has satisfied the conditions in Paragraph 3, the Surety shall promptly and at the Surety's expense defend, indemnify, and hold harmless the Owner against a duly tendered claim, demand, lien, or suit.
5. The Surety's obligations to a Claimant under this Bond shall arise after the following:
  - 5.1 Claimants who do not have a direct contract with the Contractor,
    - 5.1.1 have furnished a written notice of non-payment to the Contractor, stating with substantial accuracy the amount claimed and the name of the party to whom the materials were, or equipment was, furnished or supplied or for whom the labor was done or performed, within ninety (90) days after having last performed labor or last furnished materials or equipment included in the Claim; and
    - 5.1.2 have sent a Claim to the Surety (at the address described in Paragraph 13).
  - 5.2 Claimants who are employed by or have a direct contract with the Contractor have sent a Claim to the Surety (at the address described in Paragraph 13).
6. If a notice of non-payment required by Paragraph 5.1.1 is given by the Owner to the Contractor, that is sufficient to satisfy a Claimant's obligation to furnish a written notice of non-payment under Paragraph 5.1.1.
7. When a Claimant has satisfied the conditions of Paragraph 5.1 or 5.2, whichever is applicable, the Surety shall promptly and at the Surety's expense take the following actions:
  - 7.1 Send an answer to the Claimant, with a copy to the Owner, within sixty (60) days after receipt of the Claim, stating the amounts that are undisputed and the basis for challenging any amounts that are disputed; and
  - 7.2 Pay or arrange for payment of any undisputed amounts.
  - 7.3 The Surety's failure to discharge its obligations under Paragraph 7.1 or 7.2 shall not be deemed to constitute a waiver of defenses the Surety or Contractor may have or acquire as to a Claim, except as to undisputed amounts for which the Surety and Claimant have reached agreement. If, however, the Surety fails to discharge its obligations under Paragraph 7.1 or 7.2, the Surety shall indemnify the Claimant for the reasonable attorney's fees the Claimant incurs thereafter to recover any sums found to be due and owing to the Claimant.
8. The Surety's total obligation shall not exceed the amount of this Bond, plus the amount of reasonable attorney's fees provided under Paragraph 7.3, and the amount of this Bond shall be credited for any payments made in good faith by the Surety.
9. Amounts owed by the Owner to the Contractor under the Construction Contract shall be used for the

performance of the Construction Contract and to satisfy claims, if any, under any construction performance bond. By the Contractor furnishing and the Owner accepting this Bond, they agree that all funds earned by the Contractor in the performance of the Construction Contract are dedicated to satisfy obligations of the Contractor and Surety under this Bond, subject to the Owner's priority to use the funds for the completion of the work.

10. The Surety shall not be liable to the Owner, Claimants, or others for obligations of the Contractor that are unrelated to the Construction Contract. The Owner shall not be liable for the payment of any costs or expenses of any Claimant under this Bond and shall have under this Bond no obligation to make payments to or give notice on behalf of Claimants, or otherwise have any obligations to Claimants under this Bond.
11. The Surety hereby waives notice of any change, including changes of time, to the Construction Contract or to related subcontracts, purchase orders, and other obligations.
12. No suit or action shall be commenced by a Claimant under this Bond other than in a court of competent jurisdiction in the state in which the project that is the subject of the Construction Contract is located or after the expiration of one year from the date (1) on which the Claimant sent a Claim to the Surety pursuant to Paragraph 5.1.2 or 5.2, or (2) on which the last labor or service was performed by anyone or the last materials or equipment were furnished by anyone under the Construction Contract, whichever of (1) or (2) first occurs. If the provisions of this paragraph are void or prohibited by law, the minimum period of limitation available to sureties as a defense in the jurisdiction of the suit shall be applicable.
13. Notice and Claims to the Surety, the Owner, or the Contractor shall be mailed or delivered to the address shown on the page on which their signature appears. Actual receipt of notice or Claims, however accomplished, shall be sufficient compliance as of the date received.
14. When this Bond has been furnished to comply with a statutory or other legal requirement in the location where the construction was to be performed, any provision in this Bond conflicting with said statutory or legal requirement shall be deemed deleted herefrom and provisions conforming to such statutory or other legal requirement shall be deemed incorporated herein. When so furnished, the intent is that this Bond shall be construed as a statutory bond and not as a common law bond.
15. Upon requests by any person or entity appearing to be a potential beneficiary of this Bond, the Contractor and Owner shall promptly furnish a copy of this Bond or shall permit a copy to be made.
16. Definitions
  - 16.1 Claim: A written statement by the Claimant including at a minimum:
    1. The name of the Claimant;
    2. The name of the person for whom the labor was done, or materials or equipment furnished;
    3. A copy of the agreement or purchase order pursuant to which labor, materials, or equipment was furnished for use in the performance of the Construction Contract;
    4. A brief description of the labor, materials, or equipment furnished;
    5. The date on which the Claimant last performed labor or last furnished materials or equipment for use in the performance of the Construction Contract;
    6. The total amount earned by the Claimant for labor, materials, or equipment furnished as of the date of the Claim;
    7. The total amount of previous payments received by the Claimant; and
    8. The total amount due and unpaid to the Claimant for labor, materials, or equipment furnished as of the date of the Claim.

- 16.2 Claimant: An individual or entity having a direct contract with the Contractor or with a subcontractor of the Contractor to furnish labor, materials, or equipment for use in the performance of the Construction Contract. The term Claimant also includes any individual or entity that has rightfully asserted a claim under an applicable mechanic's lien or similar statute against the real property upon which the Project is located. The intent of this Bond shall be to include without limitation in the terms of "labor, materials, or equipment" that part of the water, gas, power, light, heat, oil, gasoline, telephone service, or rental equipment used in the Construction Contract, architectural and engineering services required for performance of the work of the Contractor and the Contractor's subcontractors, and all other items for which a mechanic's lien may be asserted in the jurisdiction where the labor, materials, or equipment were furnished.
- 16.3 Construction Contract: The agreement between the Owner and Contractor identified on the cover page, including all Contract Documents and all changes made to the agreement and the Contract Documents.
- 16.4 Owner Default: Failure of the Owner, which has not been remedied or waived, to pay the Contractor as required under the Construction Contract or to perform and complete or comply with the other material terms of the Construction Contract.
- 16.5 Contract Documents: All the documents that comprise the agreement between the Owner and Contractor.
17. If this Bond is issued for an agreement between a contractor and subcontractor, the term Contractor in this Bond shall be deemed to be Subcontractor and the term Owner shall be deemed to be Contractor.
18. Modifications to this Bond are as follows:
19. The effective date of this Bond shall be the same date as the Effective Date of the Construction Contract.

**ENDOFSECTION**

**OCEANO COMMUNITY SERVICES DISTRICT**  
**NORSWING/PERSHING WATERLINE REPLACEMENT PROJECT**  
**RULES GOVERNING PROTESTS**  
**FOR**  
**OCEANO, CA**  
**CONTRACT NO. 2019-03**

**RULES GOVERNING BID PROTESTS AND OTHER CHALLENGES TO  
AWARDS OF CONSTRUCTION CONTRACTS**

THIS PAGE LEFT BLANK INTENTIONALLY

# OCEANO COMMUNITY SERVICES DISTRICT

## Rules Governing Bid Protests And Other Challenges to Awards of Construction Contracts

---

The requirements set forth in these “Rules Governing Bid Protests And Other Challenges to Awards of Construction Contracts” (“Rules”) are mandatory and are a Bidder’s sole and exclusive remedy in the event a Bidder desires to challenge, protest or contest the award of any Construction Contract. A Bidder’s failure to comply with these requirements shall constitute a waiver of any right to challenge, protest or contest the award of a Construction Contract in any subsequent proceeding, including but not limited to, the filing of a court action.

A Bidder may not rely upon another Bidder’s compliance with the requirements of these Rules. Any Bidder that does not independently comply with the requirements set forth herein shall be deemed to have waived any right to challenge, protest or contest the award of a Construction Contract.

Nothing in these Rules affects the right of the District to reject all bids at any time prior to the award of a Construction Contract, or for the District to self-perform as provided by Public Contract Code 22038, all of which shall not constitute grounds for a bid protest.

### 1.1 Definitions

- 1.1.1 Bidder - The contractor submitting a bid in response to a District solicitation for bids on a Construction Contract.
- 1.1.2 Protestor - A Bidder who files a Protest in accordance with the provisions of these Rules.
- 1.1.3 Board – Board of Directors of the Oceano Community Services District (hereinafter, also “District”)
- 1.1.4 Construction Contract - Any Construction Contract which is formally or informally advertised for bids in which the District, or will be, a party.
- 1.1.5 Protest – Any challenge, objection, or protest to the award of a Construction Contract to any Bidder.
- 1.1.6 Response – Any response to a Protest that is filed by an Interested



Party in accordance with the provisions of these Rules.

General Manager - The person designated by the Board to assume the powers, duties, and responsibilities conferred under these Rules.

- 1.1.7 Initial Determination – A written notice by the General Manager that notifies a Bidder of the reasons why the General Manager believes that a bid is nonresponsive, or that a Bidder is not a responsible Bidder.
- 1.1.8 Interested Parties - For the purpose of these Rules, Interested Parties are defined as:
  - 1.1.8.1 The District.
  - 1.1.8.2 Any Bidder that filed a Protest or whose bid is the subject of an Initial Determination.
  - 1.1.8.3 Any Bidder whose eligibility for having the Construction Contract awarded to it as a responsible Bidder with the lowest responsive bid would be affected by the outcome of a Protest or Initial Determination.

## 1.2 General Manager's Independent Authority to Determine Bid Responsiveness and Bidder Responsibility.

- 1.2.1 Regardless of whether a Protest is submitted under these Rules, the General Manager is authorized to determine whether any bid is a responsive bid and whether any Bidder is a responsible Bidder. In the event the General Manager issues an Initial Determination, the General Manager shall provide the Interested Parties with written notice of the Initial Determination at least five (5) business days before the General Manager renders a final decision addressing the grounds stated in the Initial Determination. A final decision of the General Manager under this section 1.2 shall be the final decision of the District with no provision for reconsideration or appeal to the Board.
- 1.2.2 The General Manager need not issue an Initial Determination in order to make a final decision on whether a bid is a responsive bid or a Bidder is a responsible Bidder. A final decision can also be issued by the General Manager through the processing of a Protest pursuant to the procedures set forth in these Rules.
- 1.2.3 The General Manager reserves the right to amend or withdraw an Initial Determination at any time before the General Manager renders a final decision addressing the grounds stated in the Initial Determination. When an Initial Determination is withdrawn, it shall have the same effect as if the Initial Determination had never been made.

## 1.3 Basis for Protest

- 1.3.1 Grounds for Protest – The grounds for a Protest may include any grounds a Protestor may have for contesting or challenging the award of a Construction Contract to any Bidder, including but not limited to the following grounds:

- 1.3.1.1 A Protestor objects to a Construction Contract being awarded to another Bidder on the grounds that the other Bidder's bid is nonresponsive.
- 1.3.1.2 A Protestor objects to a Construction Contract being awarded to another Bidder on the grounds that the other Bidder is not a responsible Bidder.
- 1.3.1.3 A Protestor objects to a Construction Contract being awarded to the Protestor on the grounds that the Protestor made a mistake in its bid that entitles the Protestor to be relieved of its bid under Public Contract Code Sections 5100 et seq
- 1.3.1.4 A Protestor objects to a General Manager's Initial Determination issued under section 1.2.1 above.
- 1.3.2 Required Form of Protest - All Protests shall be made in writing, containing the information listed below, and shall be filed with the General Manager. Protests shall contain the following information:
  - 1.3.2.1 The name, address, telephone, facsimile numbers, and email address of the Protestor.
  - 1.3.2.2 The signature of the Protestor or its representative.
  - 1.3.2.3 The bid, solicitation and/or contract number.
  - 1.3.2.4 The Protest must contain a complete statement of all grounds for the Protest, and must refer to the specific portion of the bid documents that are the basis of the Protest. The Protest must set forth all supporting facts and documentation. If Protester believes there are some facts relevant to its Protest that Protester cannot adequately present in writing, Protester must describe such facts in its Protest under the heading "Facts Requiring Oral Presentation", and state therein the reasons why the Bid Protester believes it cannot adequately present those facts through documentation.
  - 1.3.2.5 All information establishing that the Protestor is a Bidder for the purpose of filing a Protest.
  - 1.3.2.6 The form of relief requested.

#### 1.4 Protest Requirements and Procedure

- 1.4.1 Standing to Protest - Protests shall be filed only by a Bidder.
- 1.4.2 Time for Filing a Protest
  - 1.4.2.1 Except as provided in sections 1.4.2.2 and 1.4.2.3 below, all Protests must be submitted in writing to the General Manager before 5 p.m. PST of the sixth (6) business day following the date upon which the bids on the Construction Contract were opened.
  - 1.4.2.2 When a Protestor objects to a Construction Contract being awarded to the Protestor on the grounds that the Protestor made a mistake in its bid that entitles the Protestor to be relieved of its bid under Public Contract Code Sections 5100 et seq, the Protest must be submitted in writing to the General Manager before 5 p.m. PST of the fifth (5) business day following the date upon

which the bids on the Construction Contract were opened pursuant to Public Contract Code Section 5103.

- 1.4.2.3 When the Protestor objects to an Initial Determination made by the General Manager under section 1.2.1 above, the Protest must be submitted in writing to the General Manager before 5 p.m. PST of the fifth (5) business day following the date upon which the Initial Determination was first delivered to Protestor (either electronically or otherwise).
- 1.4.3 Written Responses of Interested Parties - If any Interested Party desires to respond to the Protest, the Response must be submitted in writing to the General Manager within five (5) business days of the date the Protest was first delivered to the Interested Party (either electronically or otherwise). If an Interested Party believes there are some facts relevant to its Response that the Interested Party cannot adequately present in writing, the Interested Party must describe such facts in its Response under the heading "Facts Requiring Oral Presentation", and state therein the reasons why the Interested Party believes it cannot adequately present those facts through documentation.
- 1.4.4 Proof of Transmittal - All Protests, Responses, and Replies shall include documentation evidencing that all Interested Parties were concurrently sent a complete copy of the respective Protest, Response or Reply in a manner that would provide all Interested Parties with a complete copy of the respective Protest, Response or Reply no later than one (1) business day after it was sent to the General Manager. The means of transmission chosen must also provide the sending party a means of verifying the date and time the copy was received by each Interested Party. Transmission by email may be an acceptable means of transmittal.
- 1.4.5 No Ex Parte or Unilateral Communications on the Merits of a Protest - No Bidder shall have any written communications regarding the merits of a Protest with the General Manager that are not concurrently sent to all of the other Interested Parties. No Bidder shall have any oral communications regarding the merits of a Protest with the General Manager other than during an oral presentation properly noticed by the General Manager under these Rules.
- 1.4.6 Suspension of Process for Proposed Rejection of all Bids - At any time during the processing of a Protest, the General Manager may elect to indefinitely suspend any further processing of the Protest by providing written notice to all Interested Parties that the General Manager intends to recommend to the Board that all bids be rejected. All time deadlines provided in these Rules shall be tolled during any such suspension period. If the Board decides to not reject all bids, or if the General Manager otherwise decides to lift the suspension, the requirements of these Rules shall be reactivated upon the General Manager providing all Interested Parties with written notice thereof.

## 1.5 Summary Dismissal of Protest

The General Manager may summarily dismiss a protest, or specific protest allegations, at any time that the General Manager determines that the Protest is untimely, frivolous, or without merit; is not submitted in the required form of Protest, as set forth above in section 1.3.2., "Required Form of Protest;" or is submitted by a non-Bidder. In such cases, a notice of summary dismissal will be furnished to the Interested Parties. Such a summary dismissal shall be the final decision of the District with no provision for reconsideration or appeal to the Board.

#### 1.6 Decision by the General Manager Based on Written Submissions Only

In reaching a decision on the merits of a Protest, the General Manager may consider relevant documentation submitted by the Protestor and any other Interested Party. If the General Manager wishes to have additional information submitted that was not included in the Protest or in any documentation from other Interested Parties, the General Manager may make a request specifying the information sought and time for submittal. Submissions of additional information that have not been specifically requested by the General Manager may not be considered at the General Manager's sole discretion. If the General Manager does not provide an opportunity for an oral presentation under section 1.7 below, the General Manager will issue a written decision without any oral presentation. . The General Manager's decision shall be the final decision of the District with no provision for reconsideration or appeal to the Board.

#### 1.7 Decision by the General Manager Following Oral Presentation

1.7.1 The General Manager may, at his or her discretion, elect to provide an opportunity for the Protestor and other Interested Parties to make an oral presentation to the General Manager regarding the Protest. In such event, oral presentations shall be conducted in accordance with the following procedure:

1.7.1.1 Notice of Oral Presentation - The General Manager will set a date, time, and place for an oral presentation. Written notice will be sent to Interested Parties not less than five (5) business days in advance of the oral presentation unless it is agreeable to all parties that an earlier date be established. Continuances may be granted by the General Manager for good cause.

1.7.1.2 Guidelines for Oral Presentation - Oral presentations are informal in nature and shall be made by the Protestor or its authorized representative. Technical rules of evidence shall not apply. The General Manager will determine how the oral presentations will be conducted and may set time limits for the presentation. The General Manager may question Interested Parties or provide an opportunity for Interested Parties to make an oral presentation. The General Manager may request additional documentation or information prior to, during or after the oral presentation. Unless

requested by the General Manager, additional documentation or information may not be accepted.

1.7.1.3 Record of Oral Presentation - Any Interested Party may request, and in the General Manager's sole discretion, the General Manager may allow recording of the presentation. If the General Manager allows the presentation to be recorded, the Interested Party requesting that the presentation be recorded must pay the cost of recording, including the costs to make and distribute copies of the recording to the General Manager and other Interested Parties. There shall be no cost to the District.

1.7.1.4 Decisions - The General Manager will issue a written decision within 30 calendar days of the oral presentation; however, the time for issuing the written decision may be extended by the General Manager. A copy of the decision will be furnished to the Interested Parties. The decision shall be the final decision of the District with no provision for reconsideration or appeal to the Board.

## 1.8 Effect on Contracts

The failure of a District employee or department to comply with the provisions stated in these Rules shall in no way affect the validity of any Construction Contract entered into by the District.

## 1.9 General Manager Decisions on Protests Seeking Relief from a Bidder's Mistake under Public Contract Code Section 5103.

When a Protestor objects to a Construction Contract being awarded to the Bid Protester on the grounds that the Protestor made a mistake in its bid that entitles the Protestor to be relieved of its bid under Public Contract Code Sections 5100 et seq, a final decision of the General Manager that relieves the Protestor of its bid on the grounds of mistake must be approved by the Board before it can become a final decision of the District. Any other final decision of the General Manager regarding a Protestor's request to be relieved of its bid on the grounds of mistake under Public Contract Code Sections 5100 et seq, shall be the final decision of the District with no provision for reconsideration or appeal to the Board.