

**OCEANO COMMUNITY SERVICES DISTRICT  
WATER STORAGE TANK REHABILITATION PROJECT**

**OCEANO, CA  
CONTRACT NO. 2023-03**

---

- (i) Notice Inviting Bids**
- (ii) Instructions to Bidders**
- (iii) Blank Bid Forms**
- (iv) Construction Contract between District and Contractor**
- (v) General Conditions**
- (vi) Special Provisions and/or Technical Specifications & Plans and Drawings**
  - a. Advantage Technical Services, Inc – Project Manual for Oceano Community Services District’s 0.3 Million Gallon Water Tank Recoating and Roof Replacement Project**
- (vii) Reports, Supplements, Attachments, Modifications, and Exhibits attached to the above items including the following:**
  - a. Federal Award Identification #B-22-UC-06-0508 (2022 Community Development Block Grant Funds)**
  - b. Federal Labor Standards Provisions – U.S. Department of Housing and Urban Development Office of Davis-Bacon and Labor Standards**
  - c. Contract Work Hours and Safety Standards Act**
  - d. Copeland “Anti-Kickback” Act**
  - e. Code of Federal Regulations – Title 24 Housing and Urban Development**
  - f. Requirements For Affirmative Action to Ensure Employment Opportunity (Executive Order 11246)**
  - g. Civil Rights, Employment and Contracting Opportunities and Other Federal requirements**
  - h. The Davis-Bacon Act**
  - i. Davis-Bacon Requirement – Posting The Wage Decision and Notice to Employees**
  - j. The Davis-Bacon Act – Jobsite Poster (English and Spanish)**
  - k. Davis- Bacon Labor Standards**
  - l. The General Decision Number: CA20230012 10/16/2023**

- (viii) Insurance Requirements**
- (ix) Blank Performance and Payment Bond Forms**
- (x) Rules Governing Bid Protests**
- (xi) Bidding Addenda, if any**

**Deadline for submittal: December 1, 2023 at 3:00PM**

**OCEANO COMMUNITY SERVICES DISTRICT**

**NOTICE INVITING BIDS**

**FOR**

**Water Storage Tank Rehabilitation**

**OCEANO, CA**

**CONTRACT NO. 2023-03**

**OCEANO COMMUNITY SERVICES DISTRICT  
NOTICE INVITING BIDS**

Notice is given that sealed bids will be received at the District office located at 1655 Front St., before 3:00 p.m. on Friday, December 1, 2023 (“Bid Deadline”), for the following public works project:

**Water Storage Tank Rehabilitation  
OCEANO, CA  
CONTRACT NO. 2023-03**

Bids will be opened and declared by the District Business and Account Manager at 3:15 p.m. on December 1, 2023, at a public meeting at 1655 Front Street, Oceano, CA, 93445.

Any bid received at the District Office at or after 3:00 p.m. on the date specified above will not be accepted and will be returned to the bidder unopened.

Bids are required for the entire work described in the Contract Documents. The award of the contract, if it be awarded, will be to the responsible bidder with the lowest responsive bid price on the **GRAND TOTAL BASE BID EXCLUDING ADDITIVE BID ITEMS**. The District does not currently include any additive bid items on the bid sheet but reserves the right to include an additive bid item with an addendum if necessary. If additional additive bid items are included with an addendum, then the addendum will state how the lowest responsive bid price will be determined. The District reserves the right to the award of the contract after the lowest responsible bidder has been determined, and the bidder is bound by its bid amount including additive bid items, if any. Such award, if made, will be made within 90 calendar days after the opening of proposals, and bidder agrees to be bound by its bid, including all its bid prices, for the entire 90-day period. The district reserves the right to reject all bids and the right to self-perform the work as provided by Public Contract Code Section 22038. The District's Contract No. 2023-03 is federally funded.

**Description of Work**

The project is for maintenance repairs of a 0.3 MG-ground- supported-welded-steel-water tank. The Work includes removal and replacement of an existing severely corroded tank roof, structure and appurtenances with engineering, coatings and other items specified herein and as shown on the Contract Documents to result in a complete and “turn-key” storage system.

**Recommended construction days allowed**

The Work will be substantially completed within 161 days after the date when the Contract Times commence to run.

## Bid Documents

The following collection of documents are designated as the Bid Documents:

- (i) Notice Inviting Bids.
- (ii) Instructions to Bidders.
- (iii) Blank Bid Forms.
- (iv) Construction Contract between District and Contractor.
- (v) General Conditions.
- (vi) Special Provisions and/or Technical Specifications & Plans and Drawings:
  - a. Advantage Technical Services, Inc – Project Manual for Oceano Community Services District’s 0.3 Million Gallon Water Tank Recoating and Roof Replacement Project
- (vii) Reports, Supplements, Attachments, Modifications, and Exhibits attached to the above items including the following:
  - a. Federal Award Identification #B-22-UC-06-0508 (2022 Community Development Block Grant Funds)
  - b. Federal Labor Standards Provisions – U.S. Department of Housing and Urban Development Office of Davis-Bacon and Labor Standards
  - c. Contract Work Hours and Safety Standards Act
  - d. Copeland “Anti-Kickback” Act
  - e. Code of Federal Regulations – Title 24 Housing and Urban Development
  - f. Requirements For Affirmative Action to Ensure Employment Opportunity (Executive Order 11246)
  - g. Civil Rights, Employment and Contracting Opportunities and Other Federal requirements
  - h. The Davis-Bacon Act
  - i. Davis-Bacon Requirement – Posting The Wage Decision and Notice to Employees
  - j. The Davis-Bacon Act – Jobsite Poster (English and Spanish)
  - k. Davis- Bacon Labor Standards
  - l. The General Decision Number: CA20230012 10/16/2023
- (viii) Insurance Requirements
- (ix) Blank Performance and Payment Bond Forms
- (x) Rules Governing Bid Protests
- (xi) Bidding Addenda, if any.

**NOTICE PURSUANT TO THE  
UNIFORM PUBLIC CONSTRUCTION COST ACCOUNTING ACT (Act)**

The District's estimated project costs are \$569,000 for the project. Since project costs are estimated at more than \$200,000, notice is being provided pursuant to the Act.

In accordance with Public Contract Code 22037, a notice inviting formal bids including a description of the project in general terms and how to obtain more detailed information about the project, and the time and place for submission of bids, has been noticed in the San Luis Obispo Tribune and has been emailed to the following construction trade journals:

Required Journals	San Luis Obispo County Journals
Construction Bidboard (Ebidboard) 11622 El Camino Real, #100 San Diego, CA 92130 Phone: 800-479-5314 Email: support@ebidboard.com Website: www.ebidboard.com	Central Coast Builders Association 242 East Romie Lane Salinas, CA 93907 Phone: 831-758-1624 Email: staff@ccbabuilds.com Website: www.ccbabuilds.com
Dodge Data & Analytics 830 Third Avenue, 6th Floor New York, NY 10022 Phone: 877-784-9556 Email: support@construction.com Website: www.construction.com	San Luis Obispo County Builders Exchange 153 Cross Street, #130 San Luis Obispo, CA 93401 Phone: 805-543-7330 Email: info@slocbe.com Website: www.slocbe.com

Obtaining detailed information, which is the Bid package, (also referred to herein as the “Contract Documents”) are posted on the District’s website:

<https://ocsd.specialdistrict.org/bids-proposals>

If the website and/or links do not provide access to the bid package and related information, please contact the District's Business and Accounting Manager at 805-481-6730.

Any changes, additions, or deletions to these Contract Documents will be in the form of written addenda issued by the District. Any addenda will be posted on the website. Prospective bidders must check the website for addenda or other relevant new information at up to 5:00 p.m. the day before the prescribed date/time for submittal of bids. The District is not responsible for the failure of any prospective bidder to receive such addenda. All addenda so issued shall become a part of this Bid.

All bidders are required to acknowledge and confirm receipt of every addendum in their bid proposal.

All bidder Requests for Information must be submitted no later than 3:00 p.m., 5 business days prior to the bid opening date. Requests submitted after said date may not be considered. All questions pertaining to the content of this invitation to Bid must be made in writing through the District website. Questions and responses will be posted on the District website and can be

submitting the question will not be posted. The District reserves the right to determine the appropriateness of comments / questions that will be posted on the website.

The bidders must possess a valid Class **“A” General Engineering Contractor** and **“C-33” Painting and Decorating Contractor** license(s) at the time of bid issuance (Public Contract Code § 3300). Failure to possess the specified license shall render the Bid as non-responsive and shall act as a bar to award of the Contract to any bidder not possessing said license at the time of award. In the event of dispute over classification of the license required, the opinion of the contractor’s State License Board shall prevail.

PRE-BID CONFERENCE: It is mandatory that the bidder attend the pre-bid conference scheduled for **November 16, 2023 at 10:00 am** at the tank site located at 1935 Wilmar Ave Oceano, CA 93445.

The District’s project is federally funded, therefore pursuant to Davis Bacon Provisions all laborers employed or working on site shall be paid the appropriate wage rate and fringe benefits on the wage determination for the classification of work performed (see section v - Reports, Supplements, Attachments, Modifications, and Exhibits). The Contractor shall submit certified payroll weekly to the District. The prime contractor is responsible for the submission of copies of payrolls by all subcontractors.

Pursuant to California S.B. 854 and associated requirements and regulations by the Department of Industrial Relations no contractor or subcontractor may be listed on a bid proposal for a public works project unless registered with the Department of Industrial Relations pursuant to Labor Code section 1725.5 [with limited exceptions from this requirement for bid purposes only under Labor Code section 1771.1(a)]. No contractor or subcontractor may be awarded a contract for public work on a public works project unless registered with the Department of Industrial Relations pursuant to Labor Code section 1725.5. Contractors must be a registered “public works contractor” with the Department of Industrial Relations at the time of the bid.

Pursuant to section 1770 et seq. of the California Labor Code, the Contractor and all Subcontractors shall pay not less than the prevailing rate of per diem wages as determined by the Director of the California Department of Industrial Relations and comply with all applicable Labor Code provisions, which include, but are not limited to the employment of apprentices, the hours of labor, and the debarment of Contractors and Subcontractors. The Director of the California Department of Industrial Relations determines the general prevailing wage rates. Copies are available at the District Office or at the DIR website: [www.dir.ca.gov/DLSR/PWD](http://www.dir.ca.gov/DLSR/PWD) .

Pursuant to Labor Code section 1771.1:

- A Contractor or Subcontractor shall not be qualified to bid on, be listed in the Bid Proposal, subject to the requirements of Section 4104 of the Public Contract Code or engage in the performance of this public works project, unless currently registered with the Department of Industrial Relations and qualified to perform work pursuant to Labor Code section 1725.5. It is not a violation of this section for an unregistered contractor to submit a bid that is authorized by Section 7029.1 of the Business and Professions Code or by Section 10164 or 20103.5 of the Public Contract Code, provided the contractor is registered to perform public work pursuant to Section 1725.5 at the time the contract is awarded.

- This Project is subject to compliance monitoring and enforcement by the Department of Industrial Relations.

Bids must be submitted under sealed cover plainly marked as a bid and identified with the project number, the date and time for receipt of sealed bids, and the name of the bidder.

Bids must be accompanied by cash, a certified or cashier's check, or a bidder's bond in favor of the District in an amount not less than ten percent (10%) of the submitted total Base Bid.

Pursuant to Public Contract Code section 22300, the successful bidder may substitute certain securities for funds withheld by District to ensure performance under the Contract or, in the alternative, request the District to make payment of retention to an escrow agent.

The successful bidder will be required to furnish the District with payment and performance bonds, with each issued by a California admitted surety insurer equal to 100% of the Contract Price.

By order of the General Manager of the Oceano Community Services District, made this 2<sup>nd</sup> day of November, 2023.

By   
Will Clemens, General Manager  
Oceano Community Services District



**OCEANO COMMUNITY SERVICES DISTRICT**

**Water Storage Tank Rehabilitation  
INSTRUCTIONS TO BIDDERS**

**FOR**

**OCEANO, CA  
CONTRACT NO. 2023-03**

## **INSTRUCTIONS TO BIDDERS**

### **1. CONTRACT DOCUMENTS**

The Contract Documents may be obtained from the District at the location specified in the Notice to Bidders.

The Contract Documents include the Notice to Bidders, Instructions to Bidders, Bid Forms, Construction Contract, General Conditions, Special Provisions and/or Technical Specifications, Project Plans and Drawings other Contract Documents and insurance and bond requirements. Some contract documents may be incorporated by reference.

Contract Documents can be obtained from the District website at:

<https://ocsd.specialdistrict.org/bids-proposals>

If the website and/or links do not provide access to the bid package and related information, please contact the District's Business and Accounting Manager at 805-481-6730.

The District does not assume any liability or responsibility based on any defective or incomplete copying, excerpting, scanning, faxing, downloading, or printing of the Contract Documents.

### **2. JOB SITE AND CONTRACT DOCUMENT EXAMINATION**

Bidders are responsible for examining the job site and the Contract Documents, including any Addenda issued prior to the Bid Deadline, and for informing themselves with respect to local labor availability, means of transportation, necessity for security, laws and codes, local permit requirements, wage scales, local tax structure, contractors licensing requirements, availability of required insurance, and other factors that could affect the work. Bidders are responsible for consulting the standards referenced in the Contract Documents.

Submission of a Bid is a bidder's acknowledgment that the bidder has examined the job site and bid documents and is satisfied with:

1. General and local conditions to be encountered
2. Character, quality, and scope of work to be performed
3. Quantities of materials to be furnished
4. Character, quality, and quantity of surface and subsurface materials or obstacles
5. Requirements of the Contract Documents

### **3. PRE-BID CONFERENCE**

A mandatory pre-bid conference will be held on November 16, 2023 at 10:00am at the District's property located at 1935 Wilmar Ave Oceano, Ca 93445 for this Contract.

### **4. ADDENDA**

The District reserves the right to revise the Contract Documents prior to the Bid opening date. Revisions, if any, will be made by written Addenda. All Addenda issued by the District shall be included in the Bid and made part of the Contract Documents. Pursuant to Public Contract Code section 4104.5, if the District issues an Addendum that includes material changes to the work less than 72 hours prior to the Bid Deadline, the District will extend the Bid Deadline. The District may determine, in its sole discretion, whether an Addendum warrants postponement of the Bid Deadline.

All Addenda issued will be posted on the following website: <https://ocsd.specialdistrict.org/bids-proposals>

Interested persons should be aware that if the website and/or links do not provide access to the bid package and related information, they should contact the District's Business and Accounting Manager at 805-481-6730.

Prospective bidders must check the website for addenda or other relevant new information during the response period. The District is not responsible for the failure of any prospective bidder to receive such addenda. All addenda so issued shall become a part of this Bid.

All bidders are required to acknowledge and confirm receipt of each and every addendum in their Bid. Failure to acknowledge all Addenda may result in a Bid being deemed nonresponsive and not eligible for award of the Contract.

## **5. ENGINEER'S ESTIMATE**

Any engineer's estimate provided by the District relating to this work has been provided strictly for informational purposes and cannot be relied upon by any bidder as representing an accurate estimate of the value of the work. The purpose of providing any such engineer's estimate is simply to provide each potential bidder with some preliminary information relating to whether the work may be within its bonding capacity and available resources. Under no circumstance may a bidder rely upon the engineer's estimate as representing a reasonable value of the work.

## **6. COMPLETION OF BID FORMS**

Prepare bids using only copies of the Bid Forms, which are included in the Contract Documents issued by the District. The use of Bid Forms other than clear and correct photocopies of those provided by the District will not be permitted. Bids must be executed by an authorized signatory as described in these Instructions to Bidders. Bidders must fill in all blank spaces (including inserting "N/A" where applicable) and initial all interlineations, alterations, or erasures to the Bid Forms. Bidders must not delete, modify, or supplement the printed matter on the Bid Forms or make substitutions thereon. Use of black or blue ink, indelible pencil, or a typewriter is required. Deviations in the Bid Forms may result in a Bid being deemed nonresponsive and not eligible for award of the Contract.

## **7. LICENSING REQUIREMENTS**

Pursuant to section 7028.15 of the Business and Professions Code, bidders must possess licenses issued by the California Contractors State License Board for performance of this Contract. Subcontractors must possess the appropriate licenses for each specialty subcontracted.

The District has determined that bidders must have the class of license designated in the Notice to Bidders to be eligible for award of this Contract. The Contractor shall be properly licensed by the time the Contract is awarded, pursuant to the provisions of Public Contract Code section 20103.5. Failure of the bidder to obtain proper and adequate licensing for award of the Contract constitutes a failure to execute the Contract and shall result in the forfeiture of the security of the bidder.

## **8. REGISTRATION REQUIREMENTS**

A Contractor or Subcontractor shall not be qualified to bid on, be listed in a bid proposal subject to the requirements of Public Contract Code section 4104, or engage in the performance of this Contract, unless currently registered with the California Department of Industrial Relations and qualified to perform public work pursuant to Labor Code section 1725.5. It is not a violation of Labor Code section 1725.5 for an unregistered Contractor to submit a Bid on this Contract provided the Contractor is registered to perform public work pursuant to Section 1725.5 at the time this Contract is awarded.

## **9. BID SECURITY**

Each Bid shall be accompanied by Bid Security consisting of: (a) cash; (b) a certified check made payable to the Oceano Community Services District; (c) a cashier's check made payable to the Oceano Community Services District; or (d) a bidder's bond in favor of the Oceano Community Services District executed by the bidder as principal and surety as obligor, in an amount not less than 10% of the total base Bid.

The surety insurer shall be admitted to transact surety business in the State of California, as defined in Code of Civil Procedure section 995.120. Personal sureties and unregistered surety companies are unacceptable. The cash, check, or bidder's bond shall be given as a guarantee that the bidder: (1) will execute the Contract if it is awarded to the bidder, and (2) shall provide the required payment and performance bonds and insurance certificates and endorsements as required by the Contract Documents. Failure to provide the required documents may result in forfeiture of the Bid Security and the District may award the Contract to another bidder or may call for new Bids.

## **10. BID ITEM LIST**

Bidder shall submit a Bid based on the bid item quantities the District shows on the Bid Item List. The Bid Item List is included in the Bid Forms.

In case of discrepancy between the unit price and the total set forth for a unit basis item, the unit price shall prevail, except as provided:

- A. If the amount set forth as a unit price is ambiguous, unintelligible, or uncertain for any reason, or is omitted, or is the same amount as the entry in the "Total" column, then the amount set forth in the "Total" column for the item shall prevail and shall be divided by the estimated quantity for the item and the price thus obtained shall be the unit price.
- B. (Decimal Errors) If the product of the entered unit price and the estimated quantity is exactly off by a factor of ten, one hundred, etc., or one-tenth, or one-hundredth, etc. from the entered total, the discrepancy will be resolved by using the entered unit price or item total, whichever most closely approximates percentage-wise the unit price or item total in the District's final estimate of cost.

**11. DESIGNATION OF SUBCONTRACTORS (Public Contract Code 4100-4114)**

On the *Designation of Subcontractors - Base Bid and the Designation of Subcontractors – Base Plus Additive Bid forms*, Bidders shall list each Subcontractor to whom the bidder proposes to directly subcontract portions of the work in an amount in excess of 1/2 of one percent of the total Bid. The *Designation of Subcontractors* forms for listing Subcontractors are included in the Bid Forms.

For each Subcontractor listed, the *Designation of Subcontractors* forms must show:

- 1. Business name and the location of its place of business.
- 2. California contractor license number.
- 3. Public works contractor registration number
- 4. Portion of work it will perform. Show the portion of the work by:
  - 4.1. Description of portion of subcontracted work
  - 4.2. Bid item numbers for the work involved in the portion of work listed
  - 4.3. Percentage of the total Bid for each bid item listed

**12. DEBARMENT OF CONTRACTORS AND SUBCONTRACTORS**

In accordance with the provisions of the Labor Code, Contractors or Subcontractors may not perform work on a public works project with a Subcontractor who is ineligible to perform work on a public project pursuant to Federal Labor Standards Provision by the U.S. Department of Housing and Urban Development Office of Davis-Bacon and Labor Standards and pursuant to section 1777.1 or section 1777.7 of the Labor Code, section 1770 et seq, and California S.B 854. Any contract on a public works project entered into between a Contractor and a debarred Subcontractor is void as a matter of law. A debarred Subcontractor may not receive any public money for performing work as a Subcontractor on a public works contract. Any public money that is paid to a debarred Subcontractor by the Contractor shall be returned to the District. The Contractor shall be responsible for the payment of wages to workers of a debarred Subcontractor used on the work

A list of Contractors barred by the Division of Labor Standards Enforcements is available on the following Department of Industrial Relations website:

<http://www.dir.ca.gov/dlse/debar.html>

**13. DECLARATION OF NONCOLLUSION**

The *Declaration of Noncollusion* form shall be signed, under penalty of perjury, certifying that the Bid is not the result of and has not been influenced by collusion. Any Bid made without such declaration, or believed to be made in violation thereof, may be rejected.

**14. IRAN CONTRACTING ACT CERTIFICATION**

Each bidder shall submit the certification required by the Iran Contracting Act of 2010, Public Contract Code section 2200 et seq. with its Bid. The certification is included in the Bid Forms section of the Contract Documents.

## **15. SIGNING OF BIDS**

All Bids submitted shall be executed by the bidder or its authorized representative. Bidders may be asked to provide evidence in the form of an authenticated resolution of its Board of Directors or a Power of Attorney evidencing the capacity of the person signing the Bid to bind the bidder to each Bid and to any Contract.

If the bidder is a corporation, the legal name of the corporation shall be set forth on the Bid Proposal Form with the signature of the officer or officers authorized to sign contracts on behalf of the corporation. If the bidder is a partnership, the true name of the firm shall be set forth on the Bid Proposal Form with the signature of the partner or partners authorized to sign contracts on behalf of the partnership. If the bidder is an individual, his or her signature shall be placed on the Bid Proposal. If signature is by an agent, other than an officer of a corporation or a member of a partnership, a Power of Attorney must be submitted with the Bid; otherwise, the Bid will be disregarded as irregular and unauthorized.

## **16. SUBMISSION OF SEALED BIDS**

Once the Bid Forms have been completed and signed as set forth herein, place them, along with the Bid Security and other required materials, in an envelope, sealed, addressed, and delivered or mailed, postage prepaid, to the District as indicated in the Notice to Bidders. No oral or telephonic bids will be considered. No forms transmitted via the internet, e-mail, facsimile, or any other electronic means will be considered. Bids must be plainly marked as a Bid and identified with the Project number, the date and time of receipt of sealed Bids, and the name of the bidder.

## **17. DELIVERY AND OPENING OF BIDS**

Bids will be received by the District at the address shown in the Notice to Bidders prior to the date and time shown therein. The District will leave unopened any Bid received after the specified date and time, and any such unopened Bid will be returned to the bidder. It is the bidder's sole responsibility to ensure that its Bid is received as specified. Bids may be submitted earlier than the date and time indicated.

Bids will be opened as stated in the Notice to Bidders, and the amount of each Bid will be read aloud and recorded. All bidders may, if they desire, attend the opening of Bids. The District may in its sole discretion, elect to postpone the opening of the submitted Bids. District reserves the right to reject any or all Bids and to waive any informality or irregularity in any Bid.

## **18. WITHDRAWAL OF BID**

Any bidder may withdraw its Bid by written request any time prior to the time set forth in the Notice to Bidders for the opening of Bids by notice to the District's Business and Accounting Manager at 1655 Front Street, Oceano, CA 93445. Such notice shall be in writing signed by the bidder and shall be received, and date-stamped and time-stamped by the District. Withdrawn Bids may be resubmitted on or before the time set forth in the Notice to Bidders for receipt of Bids provided that they are in full conformance with the Contract Documents. Once submitted, all Bids are irrevocable, except as otherwise provided by law. Each bidder agrees by submitting a Bid that its Bid shall remain open, is irrevocable, and may not be modified, withdrawn, or cancelled for a period of at least 90 days after Bid opening. Any request for District's consent to permit a bidder to withdraw a Bid after the Bid Deadline must be made in accordance with Public Contract Code section 5100 et seq., including, but not limited to, submission of written notice to the District within 5 business days after Bid opening specifying in detail how the mistake occurred.

## **19. RESERVATION OF RIGHTS**

The District reserves the right to reject any or all bids, and to waive discrepancies, irregularities, informalities, or any other error in the bid or bidding, if to do so seems to best serve the public interest. The right of the District to waive errors applies even if the Contract Documents state that a discrepancy, irregularity, informality, or other error make a bid nonresponsive, so long as the error does not constitute a material error.

The District reserves the right, in its sole discretion, to: judge the bidder's representations as stated in the Bid forms and any post-Bid information to determine whether or not bidder is qualified to perform the work; be the sole judge regarding the suitability of the products, services, or supplies offered; to not purchase all items or the full quantity of each item listed in the Bid Item List; reject any or all Bids; waive any deficiencies, irregularities, or informalities in any Bids or in the bidding process; modify, cancel, or withdraw the Notice to Bidders; issue a new Notice to Bidders; suspend or abandon the Project; seek the assistance of outside technical experts in Bid evaluation; require a bidder to provide a

guarantee (or guarantees) of the Contract by a third party; and not issue a Notice to Proceed after execution of the Contract. In submitting a Bid in response to the Notice to Bidders, the bidder is specifically acknowledging the District holds these rights. The Notice to Bidders does not commit the District to enter into a Contract, to reject, in its sole discretion, all Bids, nor does it obligate the District pay for any costs incurred in preparation and submission of a Bid or in anticipation of a Contract. By submitting a Bid, the bidder disclaims any right to be paid for such costs.

## **20. BASIS OF AWARD; BALANCED BIDS**

The District will award the Contract to the responsible bidder that submits the lowest responsive Bid, which shall be determined as set forth in the Notice to Bidders and as provided in these Instructions to Bidders and subject to the rights reserved by the District.

## **21. DISQUALIFICATION OF BIDDERS; INTEREST IN MORE THAN ONE BID**

No bidder shall be allowed to make, submit, or be interested in more than one Bid. However, a person, firm, corporation or other entity that has submitted a proposal to a bidder, or that has quoted prices of materials to a bidder, is not thereby disqualified from submitting a proposal or quoting prices to other bidders submitting a Bid to the District or submitting a Bid to the District as a prime bidder.

A firm that the District has hired to provide architectural or engineering services to the District for this Contract before Bid submittal for this Contract is prohibited from all of the following:

1. Submitting a Bid;
2. Subcontracting for a part of the work; and
3. Supplying materials.

## **22. INSURANCE REQUIREMENTS**

The successful bidder shall procure and maintain insurance in the forms, in the amounts and for the durations specified in the General Conditions.

## **23. RESPONSIVE BID**

A responsive Bid is a Bid that conforms, in all material respects, to these Instructions to Bidders. Non-responsive Bids will be rejected.

## **24. RESPONSIBLE BIDDER**

A responsible bidder means a bidder who has demonstrated the attributes of trustworthiness, quality, fitness, capacity, and experience to satisfactorily perform fully the requirements of the Contract Documents and the moral and business integrity and reliability that will assure good faith performance in the sole discretion of the District. Any determination of a bidder's non-responsibility by the District shall be based on the fitness and capacity of the bidder to satisfactorily perform the obligations of the Contract, whether or not the bidder is qualified to perform those obligations, whether or not the bidder is trustworthy, and such other bases as may be relevant.

## **25. EVIDENCE OF RESPONSIBILITY AND ADDITIONAL INFORMATION**

In addition to other provisions of the Bidding Requirements, upon the request of the District, a bidder whose Bid is under consideration for the award of the Contract shall promptly submit satisfactory evidence to District showing the bidder's financial resources, experience in the field, and organization and other factors evidencing bidder's ability to successfully execute and complete the Contract.

## **26. AWARD PROCESS**

Once all Bids are opened and reviewed to determine the lowest responsive and responsible bidder, the District may award the Contract or reject all Bids. Once the District notifies the selected bidder of the award, the bidder will have 10 business days from the date of the award and tender of Contract to deliver to the District the executed Contract, all of the required bonds, evidence of insurance, and other materials set forth in the Contract Documents. Once the District receives all of the properly executed documents and certifications, the District will deliver the fully executed Contract to the Contractor and issue a Notice to Proceed. If the District's issuance of a Notice to Proceed is delayed due to Contractor's failure to return fully-executed Contract, insurance, bond, and other required documents within 10

working days after the award and tender of the Contract, then Contractor agrees to the deduction of 1 working day from the number of days in the Contract Time for every day of delay in District's receipt of said documents. This right is in addition to and does not affect the District's right to demand forfeiture of the Bid Security if Contractor persistently delays in providing the required documentation. The Contractor's failure to return all of the required documents within 10 working days may result in the award of the contract to the next lowest bidder or rejection of all bids if, in the General Manager's sole discretion, it is determined that uncertainty in awarding and contract execution for the work impairs the District's ability to have the work completed in a timely manner.

#### **27. RETENTION AND SUBSTITUTION OF SECURITY**

The District will make monthly progress payments based upon work performed in accordance with the Contract Documents. Unless otherwise specified in the Notice to Bidders, the District will retain five percent (5%) of each progress payment as provided by the Contract Documents. At the request and expense of the Contractor, the Contractor may substitute securities for the amount so retained, or in the alternative, request the District make payment to an escrow agent in accordance with Public Contract Code section 22300. Contractor shall have 30 days following award of the Contract to submit a written request to the District to permit substitution of securities or payment of retention to an escrow agent; failure to do so shall be deemed a waiver of the right.

#### **28. PERFORMANCE BOND AND PAYMENT (LABOR AND MATERIALS) BOND REQUIREMENTS**

The successful bidder shall deliver to the District two (2) fully executed, identical counterparts of the performance bond and payment (labor and materials) bond in the form supplied by the District and included in the Contract Documents. The penal amount of each bond shall be for one hundred percent (100%) of the total base Bid plus the additive bid items, if added by District. The surety insurer shall be admitted to transact surety business in the State of California, in accordance with Code of Civil Procedure section 995.120. Personal sureties and unregistered surety companies are unacceptable. Failure to furnish a bond within this time may, in the sole discretion of District, result in the forfeiture of the Bid Security.

#### **29. SALES AND OTHER APPLICABLE TAXES, PERMITS, LICENSES AND FEES**

Contractor and its Subcontractors performing work under this Contract will be required to pay California sales tax and other applicable taxes, and to pay for permits, licenses, and fees required by the agencies with authority in the jurisdiction in which the work will be located, unless otherwise expressly provided by the Contract Documents. Bidders shall include all applicable taxes and fees that are in effect or reasonably anticipated at the Bid Deadline in all Bid prices.

#### **30. BID PROTEST PROCEDURE**

Bid protests and other challenges to the award of this Contract must comply with Rules Governing Bid Protests and Other Challenges to Awards of Construction Contracts ("Rules"). A copy of the Rules is attached to this Contract as an appendix. In addition, any Bid protest must be submitted in writing to the Oceano Community Services District, 1655 Front Street, Oceano CA 93445; Attention: General Manager.

**END OF INSTRUCTIONS TO BIDDERS**

**OCEANO COMMUNITY SERVICES DISTRICT**

**BID FORMS**

**FOR**

**Water Storage Tank Rehabilitation**

**OCEANO, CA**

**CONTRACT NO. 2023-03**



**BID PROPOSAL FORM**  
**TO THE BOARD OF DIRECTORS**  
**OF THE OCEANO COMMUNITY SERVICES DISTRICT**

**Water Storage Tank Rehabilitation**  
**OCEANO, CA**  
**CONTRACT NO. 2023-03**

**NAME OF BIDDER** \_\_\_\_\_

**BUSINESS P.O. BOX** \_\_\_\_\_

**CITY, STATE, ZIP** \_\_\_\_\_

**BUSINESS STREET ADDRESS** \_\_\_\_\_  
(include even if P.O. Box used)

**CITY, STATE, ZIP** \_\_\_\_\_

**PHONE NO: AREA CODE (\_\_\_\_) \_\_\_\_\_**

**FAX NO: AREA CODE (\_\_\_\_) \_\_\_\_\_**

**CONTRACTOR LICENSE NO. \_\_\_\_\_ CLASSIFICATION \_\_\_\_\_**

**PUBLIC WORKS CONTRACTOR REGISTRATION NO: \_\_\_\_\_**

**TAX I.D. NUMBER: \_\_\_\_\_**

**BUSINESS TYPE (Check one): Corporation \_\_\_ Partnership \_\_\_ Sole Proprietorship \_\_\_**  
**Limited Liability Company \_\_\_**

**CONTACT PERSON NAME** \_\_\_\_\_

**CONTACT PERSON PHONE No.** \_\_\_\_\_

**CONTACT PERSON E-MAIL** \_\_\_\_\_

**EMPLOYER'S TAX IDENTIFICATION NUMBER** \_\_\_\_\_

Bidder agrees that the Bid and all prices shall remain open and shall not be withdrawn for a period of not less than **90 days** from the Bid Deadline, or until rejected by the District, whichever period is shorter.

**1. ADDENDA**

The undersigned acknowledges and confirms the receipt of the following Addenda:

<u>Addenda Number</u>	<u>Date</u>
_____	_____
_____	_____
_____	_____

and agrees that said addenda are covered in the bid proposal and shall form a part of the Contract Documents.

**2. CERTIFICATION OF INSPECTION OF THE SITE AND CONTRACT DOCUMENTS**

By signing below, bidder certifies that it: has received, carefully examined, and is fully familiar with all of the provisions of the Contract Documents, including all Addenda and attachments, and that said Contract Documents contain sufficient detail regarding the work to be performed; has notified the District of any errors or omissions in the Contract Documents and unusual site conditions; has carefully checked all words, prices, and statements in this Bid Proposal Form; and has visited the job site and conducted such other field investigations which are prudent and reasonable in preparing the Bid. Bidder agrees that the District will not be responsible for any errors or omissions on the part of the undersigned in making the Bid.

**3. BIDDER’S REPRESENTATIONS REGARDING INSURANCE AND BONDS**

This Bid is made with the full knowledge of the kind, quantity, and quality of the materials and work required and, if it is accepted by the District, the bidder will enter into a Contract and furnish the bonds, insurance and other documents including project schedule as required by the Contract Documents within 10 business days after award and tender of the Contract. **By its signature below, the bidder agrees to provide the proper evidence of insurance and bonds within 10 business days after District’s tender of the Contract. Failure to do so may result in forfeiture of Bid Security and rescission of the award by the District.**

**4. CONTRACTORS LICENSE CERTIFICATION.**

The undersigned certifies that:

Contractor’s License No. \_\_\_\_\_ issued by the California Contractors State License Board (“CSLB”) to the undersigned on, , is current, valid, has not been revoked, suspended or cancelled, and is appropriate to the work to be undertaken.

Contractor’s License Classification(s): \_\_\_\_\_

Expiration Date: \_\_\_\_\_

Name of Qualifying Individual: \_\_\_\_\_

**5. TIME FOR COMPLETION**

The bidder agrees that if awarded the Contract, it shall complete the work within 161 days after the date specific in the District’s Notice to Proceed.

**6. ATTACHMENTS TO THIS BID PROPOSAL FORM**

Enclosed herewith (except as otherwise provided for optional forms) and by this reference incorporated herein and made a part of this Bid Proposal Form are the following items:

1. Bid Item List
2. Designation of Subcontractors Base Bid Form
3. Declaration of Noncollusion
4. California Public Contract Code 10162 Questionnaire
5. California Public Contract Code 10232 Statement

6. California Public Contract Code 10285.1 Statement
7. Iran Contracting Act Certification
8. Non-Lobbying Certification for Federal-Aid Contracts
9. Disclosure of Lobbying Activities
10. Bidder's Bond or other Bid Security

Bids are to be submitted for the entire work. The amount for Bid comparison purposes will be the total of all items.

The bidder shall set forth for each unit basis item of work a unit price and a total for the item, and for each lump sum item a total for the item, all in clearly legible figures in the respective spaces provided for that purpose. In the case of unit basis items, the amount set forth under the "Total" column is the extension of the unit price bid on the basis of the approximate quantity for the item.

Accompanying this Bid Proposal is a bidder's bond, cash, cashier's check, or a certified check, payable to the Oceano Community Services District, for the sum of at least ten percent (10%) of the total of the base bid. The proceeds thereof shall become the property of the District if the Bid is withdrawn after the time fixed in the Notice to Bidders for the opening of Bids, or if, in case this Bid is accepted by the District and such bidder has received written notice that the Contract has been awarded to him/her, the undersigned shall fail within 10 business days to execute the Contract with the District and furnish all documents required in the Bid Documents. Otherwise, said Bid Security, except a bidder's bond, will be returned to the undersigned.

**7. BIDDER'S ORGANIZATION AND SIGNATURE AUTHORIZATION**

The undersigned certifies that he/she/they is/are authorized to sign this Bid and any subsequent Contract on behalf of the bidding firm or company and that the nature of this bidding firm is an individual, partnership, corporation, or limited liability company with the principals or authorized officers of the firm listed as follows:

Nature of Firm:

(Corporation, Partnership, Individual, etc.) \_\_\_\_\_

Principal Officers/Partners/Members: \_\_\_\_\_

\_\_\_\_\_

Name of President of Corporation: \_\_\_\_\_

Name of Secretary of Corporation: \_\_\_\_\_

Corporation is organized under laws of State of \_\_\_\_\_, and is authorized to transact business in the State of California.

\_\_\_\_\_  
Company/Contractor Legal Name

\_\_\_\_\_  
Signature

\_\_\_\_\_  
Name (print/type)

\_\_\_\_\_  
Title (print/type)

\_\_\_\_\_  
Date

**BID FORM - BID ITEM LIST FOR: Water Storage Tank Rehabilitation**

**BASE BID**

ITEM NO.	DESCRIPTION OF ITEM	APPROX. QUANTITY	UNIT OF MEASURE	UNIT PRICE (IN FIGURES) DOLLARS. CENTS	TOTAL AMOUNT DOLLARS. CENTS
1	Mobilization and Construction Coordination	1	Lump Sum		
2	Replace Tank Roof	1	Lump Sum		
3	Roof Appurtenances, Roof Hatch, Roof Vent, Level Gauge and Guardrail	1	Lump Sum		
4	Spiral Stairway	1	Lump Sum		
5	Interior Coatings	1	Lump Sum		
6	Exterior Coatings	1	Lump Sum		
7	Welded Patches	1	Lump Sum		
8	Demobilization	1	Lum Sum		
<b>TOTAL BASE BID</b>					

<b>ADDITIVE BID ITEM 1 - None</b>						
ITEM NO.	CODE NO.	DESCRIPTION OF ITEM	APPROX. QUANTITY	UNIT OF MEASURE	UNIT PRICE (IN FIGURES) DOLLARS. CENTS	TOTAL AMOUNT DOLLARS. CENTS
<b>TOTAL ADDITIVE BID</b>						

<b>GRAND TOTAL BASE BID PLUS ADDITIVE BID ITEMS</b>	
---	--

Name of bidder \_\_\_\_\_

Signature of bidder \_\_\_\_\_

Printed Name and Title \_\_\_\_\_

Date \_\_\_\_\_

**DESIGNATION OF SUBCONTRACTORS – BASE BID**

In accordance with the provisions of Public Contract Code section 4100 et seq., the undersigned bidder sets forth the following:

- a. The name, location of the place of business, and California contractor’s license number of each Subcontractor who will perform work or labor, or render service to the undersigned Prime Contractor in or about the construction of the work or improvement, or a Subcontractor licensed by the State of California who, under subcontract to the Prime Contractor, specially fabricates and installs a portion of the work or improvement according to detailed drawings contained in the plans and specifications, in an amount in excess of one-half of one percent of the undersigned Prime Contractor's Total Bid.
- b. The portion of the work which will be done by each such Subcontractor. Only one Subcontractor shall be listed for each such portion. If the Subcontractor is not performing all of the work under the bid item number(s) listed for that Subcontractor, the bidder shall set forth the portion of the work relating to said bid item number(s) that will be done by the Subcontractor.

Bid Item No.	Description of Trade/Portion of Work	Subcontractor Name	License No.	DIR Reg No.**	Business Address	Percent of Total Bid

By: \_\_\_\_\_  
 (Bidder's Company Name)

NOTES: \*When there is a failure to list a Subcontractor as required, or when the bidder lists two Subcontractor for the same portion of the work, the law provides that the bidder agrees that bidder is fully qualified to perform that portion itself, and that the bidder shall perform that portion itself. In such case, bidder must be authorized to perform said work. Any Bid not complying with the provisions hereof may be rejected.

\*\* Pursuant to Labor Code Section 1771.1, no contractor or Subcontractor may be listed on the bid proposal for this public works project unless registered with the Department of Industrial Relations pursuant to Labor Code Section 1725.5.

## DECLARATION OF NONCOLLUSION

In accordance with Public Contract Code Section 7106, the bidder declares as follows:

I am the \_\_\_\_\_ [title] of \_\_\_\_\_ [name] of bidder], the party making the foregoing Bid. The Bid is not made in the interest of, or on behalf of, any undisclosed person, partnership, company, association, organization, or corporation. The Bid is genuine and not collusive or sham. The bidder has not directly or indirectly induced or solicited any other bidder to put in a false or sham Bid. The bidder has not directly or indirectly colluded, conspired, connived, or agreed with any bidder or anyone else to put in a sham Bid, or to refrain from bidding. The bidder has not in any manner, directly or indirectly, sought by agreement, communication, or conference with anyone to fix the bid price of the bidder or any other bidder, or to fix any overhead, profit, or cost element of the Bid price, or of that of any other bidder. All statements contained in the Bid are true. The bidder has not, directly or indirectly, submitted his or her Bid price or any breakdown thereof, or the contents thereof, or divulged information or data relative thereto, to any corporation, partnership, company, association, organization, bid depository, or to any member or agent thereof, to effectuate a collusive or sham bid, and has not paid, and will not pay, any person or entity for such purpose. Any person executing this declaration on behalf of a bidder that is a corporation, partnership, joint venture, limited liability company, limited liability partnership, or any other entity, hereby represents that he or she has full power to execute, and does execute, this declaration on behalf of the bidder.

I declare under penalty of perjury under the laws of the State of California that the foregoing is true and correct and that this declaration is executed on:

\_\_\_\_\_ [date], at \_\_\_\_\_ [city], \_\_\_\_\_ [state].

Signed: \_\_\_\_\_

Print Name: \_\_\_\_\_

If the bidder fails to complete and properly sign this declaration, the Bid will be considered non-responsive and will be rejected.

**PUBLIC CONTRACT CODE SECTION 10162 QUESTIONNAIRE**

The bidder shall complete, under penalty of perjury, the following questionnaire:

Has the bidder, any officer of the bidder, or any employee of the bidder who has a proprietary interest in the bidder, ever been disqualified, removed, or otherwise prevented from bidding on, or completing a federal, state, or local government project because of a violation of law or a safety regulation?

Yes \_\_\_\_\_ No \_\_\_\_\_

If the answer is yes, explain the circumstances in the following space.

---

---

---

---

---

---

---

---

---

---

I declare under penalty of perjury under the laws of the State of California that the foregoing is true and correct.

Company: \_\_\_\_\_

Signed: \_\_\_\_\_

Printed Name: \_\_\_\_\_

Title: \_\_\_\_\_

Date: \_\_\_\_\_



**PUBLIC CONTRACT CODE SECTION 10232 STATEMENT**

The bidder, hereby states under penalty of perjury, that no more than one final unappealable finding of contempt of court by a federal court has been issued against the Contractor within the immediately preceding two-year period because of the bidder's failure to comply with an order of a federal court which orders the bidder to comply with an order of the National Labor Relations Board.

I declare under penalty of perjury under the laws of the State of California that the foregoing is true and correct:

Company: \_\_\_\_\_

Signed: \_\_\_\_\_

Printed Name: \_\_\_\_\_

Title: \_\_\_\_\_

Date: \_\_\_\_\_

**PUBLIC CONTRACT CODE SECTION 10285.1  
STATEMENT**

The bidder hereby declares under penalty of perjury under the laws of the State of California that the bidder has \_\_\_ , has not \_\_\_ been convicted within the preceding three years of any offenses referred to in that section, including any charge of fraud, bribery, collusion, conspiracy, or any other act in violation of any state or Federal antitrust law in connection with the bidding upon, award of, or performance of, any public works contract, as defined in Public Contract Code Section 1101, with any public entity, as defined in Public Contract Code Section 1100, including the Regents of the University of California or the Trustees of the California State University. The term "bidder" is understood to include any partner, member, officer, director, responsible managing officer, or responsible managing employee thereof, as referred to in Section 10285.1.

**Note: The bidder must place a check mark after "has" or "has not" in one of the blank spaces provided (above).**

Bidders are cautioned that making a false certification may subject the certifier to criminal prosecution.

I declare under penalty of perjury under the laws of the State of California that the foregoing is true and correct:

Company: \_\_\_\_\_

Signed: \_\_\_\_\_

Printed Name: \_\_\_\_\_

Title: \_\_\_\_\_

Date: \_\_\_\_\_

**IRAN CONTRACTING ACT CERTIFICATION**

**(Public Contract Code section 2200 et seq.)**

As required by California Public Contract Code section 2204, the Contractor certifies subject to penalty for perjury that the option checked below relating to the Contractor's status regarding the Iran Contracting Act of 2010 (Public Contract Code section 2200 et seq.) is true and correct:

- The Contractor is not:
  - (i) identified on the current list of persons and entities engaging in investment activities in Iran prepared by the California Department of General Services in accordance with subdivision (b) of Public Contract Code section 2203; or
  - (ii) a financial institution that extends, for 45 days or more, credit in the amount of \$20,000,000 or more to any other person or entity identified on the current list of persons and entities engaging in investment activities in prepared by the California Department of General Services in accordance with subdivision (b) of Public Contract Code section 2203, if that person or entity uses or will use the credit to provide goods or services in the energy sector in Iran.
- The County has exempted the Contractor from the requirements of the Iran Contracting Act of 2010 after making a public finding that, absent the exemption, the County will be unable to obtain the goods and/or services to be provided pursuant to the Contract.
- The amount of the Contract payable to the Contractor for work does not exceed \$1,000,000.

Company: \_\_\_\_\_

Signed: \_\_\_\_\_

Printed Name: \_\_\_\_\_

Title: \_\_\_\_\_

Date: \_\_\_\_\_

Note: In accordance with Public Contract Code section 2205, false certification of this form shall be reported to the California Attorney General and may result in civil penalties equal to the greater of \$250,000 or twice the Contract Price, termination of the Contract and/or ineligibility to bid on contracts for three years.

**BIDDER'S BOND**

KNOW ALL BY THESE PRESENTS:

That we, \_\_\_\_\_

\_\_\_\_\_

as Principal, and \_\_\_\_\_

\_\_\_\_\_

as Surety, are held and firmly bound unto the Oceano Community Services District, County of San Luis Obispo, State of California (hereinafter called "District") in the penal sum of Ten Percent (10%) of the total aggregate amount of the base Bid of the Principal above named, submitted by said Principal to the District for the work described below, for the payment of which sum in lawful money of the United States, well and truly to be made, we bind ourselves, our heirs, executors, administrators and successors, jointly and severally, firmly by these presents. In no case shall the liability of the Surety hereunder exceed the sum of \_\_\_\_\_

\_\_\_\_\_ (\$\_\_\_\_\_).

THE CONDITION OF THIS OBLIGATION IS SUCH,

That whereas a bid to District for certain construction specifically described as follows, for which bids are to be opened on \_\_\_\_\_, 20\_\_\_\_, has been submitted by Principal to District for:

**Water Storage Tank Rehabilitation Project  
OCEANO, CA  
CONTRACT NO. 2023-03**

NOW, THEREFORE, the penal sum guaranteed by this bond shall be forfeited to the District in the event of any of the following:

- (1) The aforesaid Principal withdraws said bid after the time fixed in the Notice to Bidders for the opening of bids; or,
- (2) Principal fails to provide the District within the time(s) specified in the aforesaid contract documents all of the completed DBE documents required to perfect the Principal's bid before the contract is awarded; or
- (3) Principal fails, within fifteen (15) business days after receipt of written notice that the contract has been awarded to Principal, to enter into a written contract with District, in the prescribed form, in accordance with the bid as accepted, and file with the District the certificates of insurance as stipulated in Article 11 of the General Conditions and the two bonds (in the prescribed forms), one to guarantee faithful performance and the other to guarantee payment for labor and materials.

Surety, for value received, hereby stipulates and agrees that no change, extension of time, alteration or addition to the terms of said contract or to the work to be performed thereunder or the specifications accompanying the same shall in any manner affect its obligations on this bond, and it does hereby waive notice of any such change, extension, alteration, or addition.

In the event suit is brought upon said bond by District and judgment is recovered, the Surety shall pay all costs incurred by District in such suit, including a reasonable attorney's fee to be fixed by the court. Death of the Principal shall not relieve Surety of its obligations hereunder.

IN WITNESS WHEREOF, we have hereunto set our hands and seals on this \_\_\_\_\_

day of \_\_\_\_\_, 20\_\_\_\_\_.

\_\_\_\_\_ (Seal)

\_\_\_\_\_ (Seal)

\_\_\_\_\_ (Seal)

Principal

\_\_\_\_\_ (Seal)

\_\_\_\_\_ (Seal)

\_\_\_\_\_ (Seal)

Surety

\_\_\_\_\_

\_\_\_\_\_

Address

NOTE: Signatures of those executing for Surety must be properly acknowledged.

NOTE TO BIDDER: Failure to complete all items on this page may cause rejection of your bid.

**CONTRACTOR'S CERTIFICATION ON  
FEDERAL CONTRACT REQUIREMENTS**

I hereby certify that I have reviewed the federal construction contract-related requirements imposed on the Contractor(s) of CDBG Grant Program-funded construction projects and fully understand all my obligations if the project is awarded to me.

Project Name: \_\_\_\_\_

Location: \_\_\_\_\_

Amount of Bid: \$ \_\_\_\_\_

\_\_\_\_\_  
Name of Bidder

\_\_\_\_\_  
Print Name and Title

\_\_\_\_\_  
Street Address

\_\_\_\_\_  
City, State Zip Code

\_\_\_\_\_  
Signature

## CERTIFICATION OF BIDDER REGARDING NON-SEGREGATED FACILITIES

(To Be Executed by Bidder and Submitted with Bid)

This certification is required pursuant to Executive Order 11246 (30 F.R. 12319-25). The bidder's attention is called to the clause entitled Equal Employment Opportunity of the General Conditions of the Contract for Construction.

"Segregated facilities," as used in this provision, means any waiting rooms, work areas, rest rooms and wash rooms, restaurants and other eating areas, time clocks, locker rooms and other storage or dressing areas, parking lots, drinking fountains, recreation or entertainment areas, transportation, and housing facilities provided for employees, that are segregated by explicit directive or are in fact segregated on the basis of race, color, religion, or national origin because of habit, local custom, or otherwise.

By the submission of this bid, the bidder certifies that it does not and will not maintain or provide for its employees any segregated facilities at any of its establishments, and that it does not and will not permit its employees to perform their services at any location under its control where segregated facilities are maintained. The bidder agrees that a breach of this certification is a violation of the Equal Employment Opportunity clause in the contract.

The bidder further agrees that (except where it has obtained identical certifications from proposed subcontractors for specific time periods) prior to entering into subcontracts which exceed \$10,000 and are not exempt from the requirements of the Equal Employment Opportunity clause, it will obtain identical certifications from the proposed subcontractors; retain the certifications in its files; and forward the following notice to the proposed subcontractors (except if the proposed subcontractors have submitted identical certifications for specific time periods):

Notice to Prospective Subcontractors of Requirement for Certifications of Non-segregated Facilities

A Certification of Non-segregated Facilities must be submitted before the award of a subcontract exceeding \$10,000 which is not exempt from the provisions of the Equal Employment Opportunity clause of the prime contract. The certification may be submitted either for each subcontract or for all subcontracts during a period (i.e., quarterly, semiannually, or annually).

**User Acknowledgement and Certification:**

I hereby certify that all the information stated herein, as well as any information provided in the accompaniment herewith, is true and accurate.

---

Authorized Applicant Name  
(Print Full Name)

---

Authorized Applicant Signature

---

Date

## **False Claims Act, 31 U.S.C. §§ 3729-3733**

### **U.S. Department of Housing and Urban Development**

(To Be Executed by Bidder and Submitted with Bid)

**False Claims Statement:** U.S. Code, Title 31, Section 3729, False Claims, provides a civil penalty of not less than \$5,000 and not more than \$10,000, **plus 3 times the amount of damages** for any person who knowingly presents, or causes to be presented, a false or fraudulent claim; or who knowingly makes, or caused to be used, a false record or statement; or conspires to defraud the Government by getting a false or fraudulent claim allowed or paid.

HUD will prosecute false claims and statements. Conviction may result in criminal and/or civil penalties. (18 U.S.C. 1001, 1010, 1012; 31 U.S.C. 3729, 3802)

#### **User Acknowledgement and Certification:**

**I hereby certify that all the information stated herein, as well as any information provided in the accompaniment herewith, is true and accurate.**

---

**Authorized Applicant Name  
(Print Full Name)**

---

**Authorized Applicant Signature**

---

**Date**

31 U.S.C. § 3729: [31 USC 3729: False claims \(house.gov\)](#)

31 U.S.C. § 3730: [31 USC 3730: Civil actions for false claims \(house.gov\)](#)

31 U.S.C. § 3731: [31 USC 3731: False claims procedure \(house.gov\)](#)

31 U.S.C. § 3732: [31 USC 3732: False claims jurisdiction \(house.gov\)](#)

31 U.S.C. § 3733: [31 USC 3733: Civil investigative demands \(house.gov\)](#)



# Certification Regarding Debarment and Suspension

## Certification A: Certification Regarding Debarment, Suspension, and Other Responsibility Matters - Primary Covered Transactions

1. The prospective primary participant certifies to the best of its knowledge and belief that its principals;

a. Are not presently debarred, suspended, proposed for debarment, declared ineligible, or voluntarily excluded from covered transactions by any Federal debarment or agency;

b. Have not within a three-year period preceding this proposal, been convicted of or had a civil judgment rendered against them for commission of fraud or a criminal offense in connection with obtaining, attempting to obtain, or performing a public (Federal, State, or local) transaction or contract under a public transaction; violation of Federal or State antitrust statutes or commission of embezzlement, theft, forgery, bribery, falsification, or destruction of records, making false statements, or receiving stolen property;

c. Are not presently indicted for or otherwise criminally or civilly charged by a governmental entity (Federal, State, or local) with commission of any of the offenses enumerated in paragraph (1)(b) of this certification; and

d. Have not within a three-year period preceding this application/proposal had one or more public transactions (Federal, State, or local) terminated for cause or default.

2. Where the prospective primary participant is unable to certify to any of the statements in this certification, such prospective participant shall attach an explanation to this proposal.

### Instructions for Certification (A)

1. By signing and submitting this proposal, the prospective primary participant is providing the certification set out below.

2. The inability of a person to provide the certification required below will not necessarily result in denial of participation in this covered transaction. The prospective participant shall submit an explanation of why it cannot provide the certification set out below. The certification or explanation will be considered in connection with the department or agency's determination whether to enter into this transaction. However, failure of the prospective primary participant to furnish a certification or an explanation shall disqualify such person from participation in this transaction.

3. The certification in this clause is a material representation of fact upon which reliance was placed when the department or agency determined to enter into this transaction. If it is later determined that the prospective primary participant knowingly rendered an erroneous certification, in addition to other remedies available to the Federal Government, the department or agency may terminate this transaction for cause of default.

4. The prospective primary participant shall provide immediate written notice to the department or agency to whom this proposal is submitted if at any time the prospective primary participant learns that its certification was erroneous when submitted or has become erroneous by reason of changed circumstances.

5. The terms **covered transaction, debarred, suspended, ineligible, lower tier covered transaction, participant, person, primary covered transaction, principal, proposal, and voluntarily excluded**, as used in this clause, have the meanings set out in the Definitions and Coverage sections of the rules implementing Executive Order 12549. You may contact the department or agency to which this proposal is being submitted for assistance in obtaining a copy of these regulations.

6. The prospective primary participant agrees by submitting this proposal that, should the proposed covered transaction be entered into, it shall not knowingly enter into any lower tier covered transaction with a person who is debarred, suspended, declared ineligible, or voluntarily excluded from participation in this covered transaction, unless authorized by the department or agency entering into this transaction.

7. The prospective primary participant further agrees by submitting this proposal that it will include the clause titled "Certification Regarding Debarment, Suspension, Ineligibility and Voluntary Exclusion - Lower Tier Covered Transaction," provided by the department or agency entering into this covered transaction, without modification, in all lower tier covered transactions and in all solicitations for lower tier covered transactions.

8. A participant in a covered transaction may rely upon a certification of a prospective participant in a lower tier covered transaction that it is not debarred, suspended, ineligible, or voluntarily excluded from the covered transaction, unless it knows that the certification is erroneous. A participant may decide the method and frequency by which it determines this eligibility of its principals. Each participant may, but is not required to, check the Nonprocurement List.

9. Nothing contained in the foregoing shall be construed to require establishment of a system of records in order to render in good faith the certification required by this clause. The knowledge and information of a participant is not required to exceed that which is normally possessed by a prudent person in the ordinary course of business dealings.

10. Except for transactions authorized under paragraph (6) of these instructions, if a participant in a covered transaction knowingly enters into a lower tier covered transaction with a person who is suspended, debarred, ineligible, or voluntarily excluded from participation in this transaction, in addition to other remedies available to the Federal Government, the department or agency may terminate this transaction for cause of default.

**Certification B: Certification Regarding Debarment, Suspension, Ineligibility and Voluntary Exclusion - Lower Tier Covered Transactions**

1. The prospective lower tier participant certifies, by submission of this proposal, that neither it nor its principals is presently debarred, suspended, proposed for debarment, declared ineligible, or voluntarily excluded from participation in this transaction by any Federal department or agency.
2. Where the prospective lower tier participant is unable to certify to any of the statements in this certification, such prospective participant shall attach an explanation to this proposal.

**Instructions for Certification (B)**

1. By signing and submitting this proposal, the prospective lower tier participant is providing the certification set out below.
2. The certification in this clause is a material representation of fact upon which reliance was placed when this transaction was entered into. If it is later determined that the prospective lower tier participant knowingly rendered an erroneous certification, in addition to other remedies available to the Federal Government, the department or agency with which this transaction originated may pursue available remedies, including suspension and/or debarment.
3. The prospective lower tier participant shall provide immediate written notice to the person to which this proposal is submitted if at any time the prospective lower tier participant learns that its certification was erroneous when submitted or has become erroneous by reason of changed circumstances.
4. The terms **covered transaction, debarred, suspended, ineligible, lower tier covered transaction, participant, person, primary covered transaction, principal, proposal, and voluntarily excluded**, as used in this clause, have the meanings set out in the Definitions and Coverage sections of rules implementing Executive Order 12549. You may contact the person to which this proposal is submitted for assistance in obtaining a copy of these regulations.

5. The prospective lower tier participant agrees by submitting this proposal that, should the proposed covered transaction be entered into, it shall not knowingly enter into any lower tier covered transaction with a person who is debarred, suspended, declared ineligible, or voluntarily excluded from participation in this covered transaction, unless authorized by the department or agency with which this transaction originated.
6. The prospective lower tier participant further agrees by submitting this proposal that it will include this clause titled "Certification Regarding Debarment, Suspension, Ineligibility and Voluntary Exclusion - Lower Tier Covered Transaction," without modification, in all lower tier covered transactions and in all solicitations for lower tier covered transactions.
7. A participant in a covered transaction may rely upon a certification of a prospective participant in a lower tier covered transaction that it is not debarred, suspended, ineligible, or voluntarily excluded from the covered transaction, unless it knows that the certification is erroneous. A participant may decide the method and frequency by which it determines the eligibility of its principals. Each participant may, but is not required to, check the Nonprocurement List.
8. Nothing contained in the foregoing shall be construed to require establishment of a system of records in order to render in good faith the certification required by this clause. The knowledge and information of a participant is not required to exceed that which is normally possessed by a prudent person in the ordinary course of business dealings.
9. Except for transactions authorized under paragraph (5) of these instructions, if a participant in a lower covered transaction knowingly enters into a lower tier covered transaction with a person who is suspended, debarred, ineligible, or voluntarily excluded from participation in this transaction, in addition to other remedies available to the Federal Government, the department or agency with which this transaction originated may pursue available remedies including suspension and/or debarment.

Applicant		Date
Signature of Authorized Certifying Official		Title

# Certification Regarding Debarment and Suspension

## Certification A: Certification Regarding Debarment, Suspension, and Other Responsibility Matters - Primary Covered Transactions

1. The prospective primary participant certifies to the best of its knowledge and belief that its principals;

a. Are not presently debarred, suspended, proposed for debarment, declared ineligible, or voluntarily excluded from covered transactions by any Federal debarment or agency;

b. Have not within a three-year period preceding this proposal, been convicted of or had a civil judgment rendered against them for commission of fraud or a criminal offense in connection with obtaining, attempting to obtain, or performing a public (Federal, State, or local) transaction or contract under a public transaction; violation of Federal or State antitrust statutes or commission of embezzlement, theft, forgery, bribery, falsification, or destruction of records, making false statements, or receiving stolen property;

c. Are not presently indicted for or otherwise criminally or civilly charged by a governmental entity (Federal, State, or local) with commission of any of the offenses enumerated in paragraph (1)(b) of this certification; and

d. Have not within a three-year period preceding this application/proposal had one or more public transactions (Federal, State, or local) terminated for cause or default.

2. Where the prospective primary participant is unable to certify to any of the statements in this certification, such prospective participant shall attach an explanation to this proposal.

### Instructions for Certification (A)

1. By signing and submitting this proposal, the prospective primary participant is providing the certification set out below.

2. The inability of a person to provide the certification required below will not necessarily result in denial of participation in this covered transaction. The prospective participant shall submit an explanation of why it cannot provide the certification set out below. The certification or explanation will be considered in connection with the department or agency's determination whether to enter into this transaction. However, failure of the prospective primary participant to furnish a certification or an explanation shall disqualify such person from participation in this transaction.

3. The certification in this clause is a material representation of fact upon which reliance was placed when the department or agency determined to enter into this transaction. If it is later determined that the prospective primary participant knowingly rendered an erroneous certification, in addition to other remedies available to the Federal Government, the department or agency may terminate this transaction for cause of default.

4. The prospective primary participant shall provide immediate written notice to the department or agency to whom this proposal is submitted if at any time the prospective primary participant learns that its certification was erroneous when submitted or has become erroneous by reason of changed circumstances.

5. The terms **covered transaction, debarred, suspended, ineligible, lower tier covered transaction, participant, person, primary covered transaction, principal, proposal, and voluntarily excluded**, as used in this clause, have the meanings set out in the Definitions and Coverage sections of the rules implementing Executive Order 12549. You may contact the department or agency to which this proposal is being submitted for assistance in obtaining a copy of these regulations.

6. The prospective primary participant agrees by submitting this proposal that, should the proposed covered transaction be entered into, it shall not knowingly enter into any lower tier covered transaction with a person who is debarred, suspended, declared ineligible, or voluntarily excluded from participation in this covered transaction, unless authorized by the department or agency entering into this transaction.

7. The prospective primary participant further agrees by submitting this proposal that it will include the clause titled "Certification Regarding Debarment, Suspension, Ineligibility and Voluntary Exclusion - Lower Tier Covered Transaction," provided by the department or agency entering into this covered transaction, without modification, in all lower tier covered transactions and in all solicitations for lower tier covered transactions.

8. A participant in a covered transaction may rely upon a certification of a prospective participant in a lower tier covered transaction that it is not debarred, suspended, ineligible, or voluntarily excluded from the covered transaction, unless it knows that the certification is erroneous. A participant may decide the method and frequency by which it determines this eligibility of its principals. Each participant may, but is not required to, check the Nonprocurement List.

9. Nothing contained in the foregoing shall be construed to require establishment of a system of records in order to render in good faith the certification required by this clause. The knowledge and information of a participant is not required to exceed that which is normally possessed by a prudent person in the ordinary course of business dealings.

10. Except for transactions authorized under paragraph (6) of these instructions, if a participant in a covered transaction knowingly enters into a lower tier covered transaction with a person who is suspended, debarred, ineligible, or voluntarily excluded from participation in this transaction, in addition to other remedies available to the Federal Government, the department or agency may terminate this transaction for cause of default.

**Certification B: Certification Regarding Debarment, Suspension, Ineligibility and Voluntary Exclusion - Lower Tier Covered Transactions**

1. The prospective lower tier participant certifies, by submission of this proposal, that neither it nor its principals is presently debarred, suspended, proposed for debarment, declared ineligible, or voluntarily excluded from participation in this transaction by any Federal department or agency.
2. Where the prospective lower tier participant is unable to certify to any of the statements in this certification, such prospective participant shall attach an explanation to this proposal.

**Instructions for Certification (B)**

1. By signing and submitting this proposal, the prospective lower tier participant is providing the certification set out below.
2. The certification in this clause is a material representation of fact upon which reliance was placed when this transaction was entered into. If it is later determined that the prospective lower tier participant knowingly rendered an erroneous certification, in addition to other remedies available to the Federal Government, the department or agency with which this transaction originated may pursue available remedies, including suspension and/or debarment.
3. The prospective lower tier participant shall provide immediate written notice to the person to which this proposal is submitted if at any time the prospective lower tier participant learns that its certification was erroneous when submitted or has become erroneous by reason of changed circumstances.
4. The terms **covered transaction, debarred, suspended, ineligible, lower tier covered transaction, participant, person, primary covered transaction, principal, proposal, and voluntarily excluded**, as used in this clause, have the meanings set out in the Definitions and Coverage sections of rules implementing Executive Order 12549. You may contact the person to which this proposal is submitted for assistance in obtaining a copy of these regulations.

5. The prospective lower tier participant agrees by submitting this proposal that, should the proposed covered transaction be entered into, it shall not knowingly enter into any lower tier covered transaction with a person who is debarred, suspended, declared ineligible, or voluntarily excluded from participation in this covered transaction, unless authorized by the department or agency with which this transaction originated.
6. The prospective lower tier participant further agrees by submitting this proposal that it will include this clause titled "Certification Regarding Debarment, Suspension, Ineligibility and Voluntary Exclusion - Lower Tier Covered Transaction," without modification, in all lower tier covered transactions and in all solicitations for lower tier covered transactions.
7. A participant in a covered transaction may rely upon a certification of a prospective participant in a lower tier covered transaction that it is not debarred, suspended, ineligible, or voluntarily excluded from the covered transaction, unless it knows that the certification is erroneous. A participant may decide the method and frequency by which it determines the eligibility of its principals. Each participant may, but is not required to, check the Nonprocurement List.
8. Nothing contained in the foregoing shall be construed to require establishment of a system of records in order to render in good faith the certification required by this clause. The knowledge and information of a participant is not required to exceed that which is normally possessed by a prudent person in the ordinary course of business dealings.
9. Except for transactions authorized under paragraph (5) of these instructions, if a participant in a lower covered transaction knowingly enters into a lower tier covered transaction with a person who is suspended, debarred, ineligible, or voluntarily excluded from participation in this transaction, in addition to other remedies available to the Federal Government, the department or agency with which this transaction originated may pursue available remedies including suspension and/or debarment.

Applicant		Date
Signature of Authorized Certifying Official	Title	

**OCEANO COMMUNITY SERVICES DISTRICT**

**Water Storage Tank Rehabilitation**

**CONSTRUCTION CONTRACT**

**FOR**

**OCEANO, CA**

**CONTRACT NO. 2023-03**

OCEANO COMMUNITY SERVICES DISTRICT

CONSTRUCTION CONTRACT

WATER STORAGE TANK REHABILITATION

PROJECT # 2023-03

## TABLE OF CONTENTS

SECTION 1	INCORPORATION OF RECITALS AND DEFINITIONS.....	4
SECTION 2	THE PROJECT. ....	4
SECTION 3	THE CONTRACT DOCUMENTS .....	4
SECTION 4	THE WORK.....	5
SECTION 5	PROJECT TEAM.....	5
SECTION 6	TIME OF COMPLETION.....	5
SECTION 7	COMPENSATION TO CONTRACTOR.....	7
SECTION 8	STANDARD OF CARE.....	8
SECTION 9	INDEMNIFICATION.....	8
SECTION 10	COMPLIANCE WITH APPLICABLE CODE REQUIREMENTS.....	8
SECTION 11	INSURANCE AND BONDS.....	9
SECTION 12	PROHIBITION AGAINST TRANSFERS.....	9
SECTION 13	NOTICES.....	9
SECTION 14	DISPUTE RESOLUTION.....	10
SECTION 15	DEFAULT.....	14
SECTION 16	DISTRICT'S RIGHTS AND REMEDIES .....	14
SECTION 17	CONTRACTOR'S RIGHTS AND REMEDIES.....	17
SECTION 18	ACCOUNTING RECORDS.....	18
SECTION 19	INDEPENDENT PARTIES.....	18
SECTION 20	NUISANCE.....	19
SECTION 21	PERMITS AND LICENSES.....	19
SECTION 22	WAIVER.....	19
SECTION 23	CONFLICTS WITH THE CONSTRUCTION CONTRACT.....	19
SECTION 24	GOVERNING LAW AND VENUE.....	19
SECTION 25	COMPLETE AGREEMENT.....	19
SECTION 26	SURVIVAL OF CONTRACT.....	19
SECTION 27	ADDITIONAL CONTRACT REQUIREMENTS.....	20
SECTION 28	SPECIFIC REQUIREMENTS FOR PUBLIC WORKS CONTRACTORS.....	21
SECTION 29	GOVERNMENTAL POWERS .....	22
SECTION 30	SEVERABILITY.....	23
SECTION 31	EXHIBITS.....	23

---

## CONSTRUCTION CONTRACT

THIS CONSTRUCTION CONTRACT entered into on \_\_\_\_\_, 2023 (“Execution Date”) by and between the OCEANO COMMUNITY SERVICES DISTRICT, a California community services district (“District”), and \_\_\_\_\_ (“Contractor”), is made with reference to the following:

### **RECITALS:**

A. District is a community services district duly organized and validly existing under the laws of the State of California with the power to carry on its business as it is now being conducted under the statutes of the State of California.

B. Contractor is a Corporation or company duly organized and in good standing in the State of California, License Number \_\_\_\_\_. Contractor represents that it is duly licensed by the State of California and has the background, knowledge, experience, and expertise to perform the obligations set forth in this Construction Contract.

C. On \_\_\_\_\_, District issued a Notice Inviting Bids to contractors for the Water Storage Tank Rehabilitation Project. A copy of District’s Notice Inviting Bids and Instructions to Bidders is attached hereto as Exhibit “A” and incorporated by reference. In response to District’s Notice Inviting Bids, Contractor submitted its Bid. A copy of Contractor’s Bid is attached hereto as Exhibit “B” and incorporated herein by reference. Also attached hereto and incorporated by reference are the following:

- Exhibit C – General Conditions.
- Exhibit D – Special Provisions and/or Technical Specifications & Plans and Drawings
  - Advantage Technical Services, Inc – Project Manual for Oceano Community Services District’s 0.3 Million Gallon Water Tank Recoating and Roof Replacement Project
- Exhibit E – Performance and Payment Bonds.
- Exhibit F – Insurance Requirements.
- Exhibit G – Rules Governing Bid Protests
- Exhibit H - Reports, Supplements, Attachments, Modifications, and Exhibits attached to the above items including:
  - Federal Award Identification #B-22-UC-06-0508 (2022 Community Development Block Grant Funds)
  - Federal Labor Standards Provisions – U.S. Department of Housing and Urban Development Office of Davis-Bacon and Labor Standards
  - Contract Work Hours and Safety Standards Act
  - Copeland “Anti-Kickback” Act
  - Code of Federal Regulations – Title 24 Housing and Urban Development
  - Requirements For Affirmative Action to Ensure Employment Opportunity (Executive Order 11246)
  - Civil Rights, Employment and Contracting Opportunities and Other Federal requirements
  - The Davis-Bacon Act
  - Davis-Bacon Requirement – Posting The Wage Decision and Notice to Employees



- The Davis-Bacon Act – Jobsite Poster (English and Spanish)
- Davis- Bacon Labor Standards
- The General Decision Number: CA20230012 10/16/2023

D. District and Contractor desire to enter into this Construction Contract for the Water Storage Tank Rehabilitation Project, and other services as identified in the Bid Documents upon the following terms and conditions.

NOW THEREFORE, in consideration of the mutual promises and undertakings hereinafter set forth and for other good and valuable consideration, the receipt and sufficiency of which are hereby acknowledged, it is mutually agreed by and between the undersigned parties as follows:

## **SECTION 1 INCORPORATION OF RECITALS AND DEFINITIONS.**

### **1.1 Recitals.**

All of the recitals are incorporated herein by reference.

### **1.2 Definitions.**

Capitalized terms shall have the meanings set forth in this Construction Contract and/or in the General Conditions. If there is a conflict between the definitions in this Construction Contract and in the General Conditions, the definitions in this Construction Contract shall prevail.

## **SECTION 2 THE PROJECT.**

The Project is the construction of the Water Storage Tank Rehabilitation Project ("Project").

## **SECTION 3 THE CONTRACT DOCUMENTS.**

The Contract Documents consist of the following collection of documents:

- (i) Executed Construction Contract between District and Contractor.
- (ii) Notice Inviting Bids.
- (iii) Instructions to Bidders.
- (iv) Bidding Addenda.
- (v) Contractor's Bid.
- (vi) General Conditions.
- (vii) Special Provisions and Technical Specifications.
- (viii) Plans and Drawings.
- (ix) Performance and Payment Bonds.
- (x) Insurance Forms.
- (xi) Reports listed in the Bidding Documents.
- (xii) Supplements, Attachments, and Exhibits attached to the above items.
- (xiii) Modifications.
- (xiv) Change Orders.
- (xv) Field Orders.
- (xvi) Other documents as so designated by written agreement of the Parties.

## **SECTION 4            THE WORK.**

The Work includes all labor, materials, equipment, services, permits, licenses and taxes, and all other things necessary for Contractor to perform its obligations and complete the Project, including, without limitation, any Changes requested by District, in accordance with the Contract Documents and all Applicable Code Requirements.

## **SECTION 5            PROJECT TEAM.**

In addition to Contractor, District has retained, or may retain, consultants and contractors to provide professional and technical consultation for the design and construction of the Project. The Project requires that Contractor operate efficiently, effectively, and cooperatively with District as well as all other members of the Project Team.

## **SECTION 6            TIME OF COMPLETION.**

### **6.1    Time Is of the Essence.**

All time limits for Milestones, if any, Substantial Completion, and completion and readiness for final payment as stated in the Contract Documents are of the essence of the Contract.

### **6.2    Commencement of Work.**

Contractor shall commence the Work on the date specified in District's Notice to Proceed.

### **6.3    Contract Time.**

Contractor shall diligently prosecute the Work to Substantial Completion within 161 days after the date specified in the District's Notice of Proceed.

### **6.4    Liquidated Damages.**

#### **6.4.1    Entitlement.**

District and Contractor acknowledge and agree that if Contractor fails to fully and satisfactorily complete the Work within the Contract Time, District will suffer, as a result of Contractor's failure, substantial damages which are both extremely difficult and impracticable to ascertain. Such damages may include, but are not limited to:

- (i)    Loss of public confidence in District and its contractors and consultants.
- (ii)    Loss of public use of public facilities.
- (iii)    Extended disruption to public.

#### **6.4.2    Daily Amount.**

District and Contractor have reasonably endeavored, but failed, to ascertain the precise amount in relation to the actual damage that District will incur if Contractor fails to achieve Substantial Completion of the entire Work within the Contract Time. Therefore, the parties agree that in addition to all other damages to which District may be entitled, in the event Contractor shall fail to achieve Substantial Completion of the entire Work within the Contract Time, Contractor shall pay District as liquidated damages the amount of \$1,000 per day for each Day occurring after the expiration of the Contract Time until Contractor achieves Substantial Completion of the entire Work. Out-of-service time will be defined as starting from completion of tank drainage and, if selected by the District, bottom corrosion testing and ending with completion of the Work and sealing of the tank. Contractor shall pay District \$1,500 for each day that expires after 105 calendar days until the Work is

complete and the tank is sealed. The liquidated damages amount is not a penalty but considered to be a reasonable estimate of the amount of damages District will suffer.

#### **6.4.3 Apportionment.**

Such liquidated damages shall be subject to apportionment for delays to Substantial Completion for which Contractor is entitled to receive an extension of time under the Contract Documents. Such apportionment shall not be affected by the fact that liquidated damages may not be capable of apportionment for other periods of time during which there have occurred delays concurrently caused by both District and Contractor. It being the Contractor's obligation to have the entire Work Substantially Completed within the Contract Time, it is agreed that such liquidated damages shall not be apportioned for portions of the Work completed prior to expiration of the Contract Time.

#### **6.4.4 Damages upon Abandonment.**

In the event that Contractor either abandons the Work or is terminated for default in accordance with the provisions of Section 15 of this Construction Contract, District shall have the right to liquidated damages pursuant to Paragraph 6.4 in addition to all actual Losses proximately resulting from Contractor's failure to complete the Work within the Contract Time.

#### **6.4.5 Other Remedies.**

The parties further acknowledge and agree that District is entitled to any and all available legal and equitable remedies District may have where District's Losses are caused by any reason other than Contractor's failure to achieve Substantial Completion of the entire Work within the Contract Time.

### **6.5 Adjustments to Contract Time.**

The Contract Time may only be adjusted for time extensions approved by District and agreed to by Change Order executed by District and Contractor in accordance with the requirements of the Contract Documents.

### **6.6 Additional Compensation to Contractor.**

The Contract Sum shall be increased by the amount of \$250.00 for each day of extension to the Contract Time that is permitted under the terms of the General Conditions solely due to Compensable Delay occurring prior to Substantial Completion, but only to the extent that such Compensable Delay is not concurrent with a Non-Compensable Delay.

Regardless of the cause of the Delay (including, without limitation, acts or omissions of District or its consultants, errors, conflicts or omissions in the Contract Documents, or Changes to the Work), Contractor agrees to accept the compensation provided for in this Paragraph as its sole and exclusive right, remedy and recovery arising from or related to any Delay, interruption, hindrance, compression, acceleration, disruption or the impact or ripple effect of Delays on the Work, that may occur in connection with Contractor's performance of Work on the Project and for any resulting foreseen or unforeseen:

- (i) Overhead expenses such as, but not limited to, additional supervision, administration, extended or extraordinary overhead (direct or home office), insurance or bond costs; and
- (ii) Productivity expenses such as additional loss of productivity, inefficiency, and

escalation of costs of labor, wage, material, or equipment.

## **SECTION 7                    COMPENSATION TO CONTRACTOR.**

### **7.1 Contract Sum.**

Contractor shall be compensated for satisfactory completion of the Work in compliance with the Contract Documents the Contract Sum of \_\_\_\_\_ (\$).

### **7.2 Full Compensation.**

The Contract Sum shall be full compensation for all Work provided by Contractor and, except as otherwise expressly permitted by the terms of the Contract Documents, shall cover all Losses arising out of the nature of the Work or from the acts of the elements or any unforeseen difficulties or obstructions which may arise or be encountered in performance of the Work until its Acceptance by District, all risks connected with the Work, and any and all expenses incurred due to suspension or discontinuance of the Work. The Contract Sum may only be adjusted for Change Orders issued, executed, and satisfactorily performed in accordance with the requirements of the Contract Documents.

### **7.3 Compensation for Extra or Deleted Work.**

The Contract Sum shall be adjusted (either by addition or credit) for Changes in the Work involving Extra Work or Deleted Work based on both of the following:

- (i) The sum of Allowable Costs as defined in Paragraph 7.2.5 of the General Conditions to be added (for Extra Work) or credited (for Deleted Work); and
- (ii) An additional sum (for Extra Work) or deductive credit (for Deleted Work) based on Contractor Markup and Subcontractor/Sub-subcontractor Markups allowable pursuant to this Section 7.3.

Contractor Markup and Subcontractor/Sub-subcontractor Markups set forth herein are the full amount of compensation to be added for Extra Work or to be subtracted for Deleted Work that is attributable to overhead (direct and indirect) and profit of Contractor and of its Subcontractors and Sub-subcontractors, of every Tier. Contractor Markup and Subcontractor/Sub-subcontractor Markups, which shall not be compounded, shall be computed as follows:

#### **7.3.1 Self-Performed Work.**

Fifteen percent (15%) of the Allowable Costs for that portion of the Extra Work or Deleted Work to be performed by Contractor with its own forces.

#### **7.3.2 Subcontractors.**

15% of the Allowable Costs for that portion of the Extra Work or Deleted Work to be performed by a first Tier Subcontractor with its own forces, plus 2.5% thereon for Contractor Markup.

#### **7.3.3 Sub-subcontractors.**

15% of the Allowable Costs of that portion of the Work to be performed by Sub-subcontractors of the second and lower Tier with their own forces, plus 2.5% thereon for the Subcontractor, plus 2.5% on the combined total thereof for Contractor Markup.

**SECTION 8 STANDARD OF CARE.**

Contractor agrees that the Work shall be performed by qualified, experienced, and well-supervised personnel. All services performed in connection with this Construction Contract shall be performed in a manner consistent with the standard of care under California law applicable to those who specialize in providing such services for projects of the type, scope, and complexity of the Project.

**SECTION 9 INDEMNIFICATION.****9.1 Hold Harmless.**

To the fullest extent allowed by law, Contractor hereby agrees to defend, indemnify, and hold harmless District, its District Board of Directors, officers, agents, employees, representatives, and volunteers (hereinafter collectively referred to as "Indemnitees"), through legal counsel acceptable to District, from and against any and all Losses, claims, causes of action arising directly or indirectly from, or in any manner relating to any of, the following:

- (i) Performance or nonperformance of the Work by Contractor or its Subcontractors or Sub-subcontractors, of any Tier;
- (ii) Performance or nonperformance by Contractor or its Subcontractors or Sub-subcontractors, of any Tier, of any of the obligations under the Contract Documents;
- (iii) The construction activities of Contractor or its Subcontractors or Sub-subcontractors, of any Tier, either on the Site or on other properties;
- (iv) The payment or nonpayment by Contractor of any of its Subcontractors or Sub-subcontractors, of any Tier, for Work performed on or off the Site for the Project; and
- (v) Any personal injury, including but not limited to bodily injury or death, arising out of or relating to the performance or non-performance of the Work.
- (vi) Any injury, property damage or economic loss to third parties associated with the performance or nonperformance by Contractor or its Subcontractors or Sub-subcontractors, of any Tier, of the Work.

However, nothing contained herein shall be construed as obligating Contractor to indemnify any Indemnitee for Losses resulting from the sole or active negligence or willful misconduct of the Indemnitee. Contractor shall pay District for any costs incurred in enforcing this provision. Nothing in the Contract Documents shall be construed to give rise to any implied right of indemnity in favor of Contractor against District or any other Indemnitee.

**9.2 Survival.**

The provisions of Section 9 shall survive the termination of this Construction Contract.

**SECTION 10 COMPLIANCE WITH APPLICABLE CODE REQUIREMENTS.**

This Project constitutes "public works" within the meaning of California Labor Code section 1720 and the federally required Davis-Bacon Act and is subject to the prevailing wage laws. Contractor

agrees to be subject to and comply with all applicable federal, state and municipal laws, codes, ordinances and regulations governing the Work, including, but not limited to applicable provisions of the Federal and California Labor Code. See Section 28 for more information on requirements.

## **SECTION 11            INSURANCE AND BONDS.**

Prior to the commencement of any Work, Contractor shall provide District with evidence that it has obtained insurance and Performance and Payment Bonds satisfying all requirements in Article 11 of the General Conditions. Failure to do so shall be deemed a material breach of this Construction Contract.

## **SECTION 12            PROHIBITION AGAINST TRANSFERS.**

District is entering into this Construction Contract based upon the stated experience and qualifications set forth in Contractor's Bid. Accordingly, Contractor shall not assign, hypothecate, or transfer this Construction Contract or any interest therein directly or indirectly, by operation of law or otherwise without the prior written consent of District. Any assignment, hypothecation, or transfer without said consent shall be null and void.

For purposes of applying the provisions of this Section, the sale, assignment, transfer, or other disposition of any of the issued and outstanding capital stock of Contractor or of any general partner or joint venture or syndicate member of Contractor, if a partnership or joint venture or syndicate or co-tenancy exists, which shall result in changing the control of Contractor, shall be construed as an assignment of this Construction Contract. Control means more than fifty percent (50%) of the voting power of the corporation or other entity.

## **SECTION 13            NOTICES.**

### **13.1 Method of Notice.**

Except as provided in Section 13.2 below, all notices, demands, requests or approvals to be given under this Construction Contract shall be given in writing and conclusively shall be deemed served on the earlier of the following:

- (i) On the date delivered, if delivered personally;
- (ii) On the third business day after the deposit thereof in the United States mail, postage prepaid, and addressed as hereinafter provided;
- (iii) On the date sent, if sent by facsimile transmission; or
- (iv) On the date it is accepted or rejected, if sent by certified mail.

### **13.2 Notice Recipients.**

All notices, demands or requests (including, without limitation, Claims) from Contractor to District at:

Oceano Community Services District  
1655 Front Street  
Oceano, CA 93455  
Attn: General Manager

In addition, copies of all Claims by Contractor under this Construction Contract shall be provided to the following:

Daniel Cheung  
P.O. Box 3835  
San Luis Obispo, CA 93403-3835

All Claims shall be delivered personally or sent by certified mail.

All notices, demands, requests or approvals from District to Contractor shall be addressed to:

Contractor contact information:

---

### **13.3 Change of Address.**

In the event of any change of address, the moving party is obligated to notify the other party of the change of address in writing. Each party may, by written notice only, add, delete or replace any listed individuals.

## **SECTION 14 DISPUTE RESOLUTION.**

### **14.1 Resolution of Contract Disputes.**

Contractor Claims (as defined by Public Contract Code Section 9204(c)) and General Conditions Section 1.1.18 shall be resolved by the parties in accordance with General Conditions Section 4.2 and applicable law. The procedures set forth in General Conditions Section 4.2 shall be the exclusive recourse of Contractor for such claims.

### **14.2 Resolution of Other Disputes.**

#### **14.2.1 Other Disputes.**

The definition of Contractor Claims shall not include any of the following:

- (i) Penalties or forfeitures prescribed by statute or regulation imposed by a governmental agency (other than relief from damages or penalties for delay assessed by a public entity under a contract for a public works project);
- (ii) Third party tort claims for personal injury, property damage or death relating to any Work performed by Contractor or its Subcontractors or Sub-subcontractors of any Tier;
- (iii) False claims liability under California Government Code Section 12650, et. seq.;
- (iv) Defects in the Work first discovered by District after Final Payment by District to Contractor; or
- (vi) The right of District to specific performance or injunctive relief to compel performance of any provision of the Contract Documents or for other District claims against the Contractor.

#### **14.2.2 Litigation, District Election.**

---

Matters that do not constitute Contractor Claims shall be resolved by way of an action filed in the Superior Court of the State of California, County of San Luis Obispo, and shall not be subject to the Contract Dispute Resolution Process. However, the District reserves the right, in its sole and absolute discretion, to treat such disputes as Contract Disputes.

Upon written notice by District of its election as provided in the preceding sentence, such dispute shall be submitted by the parties and finally decided pursuant to the Contract Dispute Resolution Process in the manner as required for Contract Disputes, including, without limitation, District's right under Paragraph 14.4.2 to defer resolution and final determination until after Final Completion of the Work.

### **14.3 Submission of Contractor Claim.**

#### **14.3.1 By Contractor.**

Contractor shall submit a written Contractor Claim in accordance with Section 4.2 of the General Conditions.

#### **14.3.2 By District.**

District's right to commence the Contract Dispute Resolution Process shall arise at any time following District's actual discovery of the circumstances giving rise to the Contract Dispute. Nothing contained herein shall preclude District from asserting Contract Disputes in response to a Claim asserted by Contractor. A Statement of Contract Dispute submitted by District shall state the events or circumstances giving rise to the Contract Dispute, the dates of their occurrence and the damages or other relief claimed by District as a result of such events.

### **14.4 Contract Dispute Resolution Process.**

The parties shall utilize each of the following steps in the Contract Dispute Resolution Process in the sequence they appear below. Each party shall participate fully and in good faith in each step in the Contract Dispute Resolution Process, which good faith effort shall be a condition precedent to the right of each party to proceed to the next step in the process.

#### **14.4.1 Response by District.**

The time periods for the District's response are set forth in General Conditions Section 4.2.6; however, any failure to respond shall be governed by General Condition Section 4.2.9.

#### **14.4.2 Meet and Confer Conference.**

If the claimant disputes the District's written response, or if the District fails to respond to a claim issued within the time prescribed in General Conditions Section 4.2, the claimant may demand in writing an informal conference to meet and confer for settlement of the issue in dispute. Upon receipt of a demand in writing sent by registered mail or certified mail, return receipt requested, the District shall schedule a meet and confer conference within 30 days for settlement of the dispute.

#### **14.4.3 Mediation.**

(i) Within ten (10) business days following the conclusion of the meet and confer conference, if the claim or any portion of the claim remains in dispute, the District shall provide the claimant a written statement identifying the portion of



the claim that remains in dispute and the portion that is undisputed. Any payment due on an undisputed portion of the claim shall be processed and made within sixty (60) days after the public entity issues its written statement. Any disputed portion of the claim, as identified by the contractor in writing, shall be submitted to nonbinding mediation, with the District and the claimant sharing the associated costs equally.

The District and the claimant shall mutually agree to a mediator within ten (10) business days after the disputed portion of the claim has been identified in writing. If the parties cannot agree upon a mediator, each party shall select a mediator and those mediators shall select a qualified neutral third party to mediate with regard to the disputed portion of the claim. Each party shall bear the fees and costs charged by its respective mediator in connection with the selection of the neutral mediator. If mediation is unsuccessful, the parts of the claim remaining in dispute shall be subject to applicable procedures outside this section.

(ii) For purposes of this section, mediation includes any nonbinding process, including, but not limited to, neutral evaluation or a dispute review board, in which an independent third party or board assists the parties in dispute resolution through negotiation or by issuance of an evaluation. Any mediation utilized shall conform to the timeframes in this section.

(iii) Unless otherwise agreed to by the District and the contractor in writing, the mediation conducted pursuant to this section shall excuse any further obligation under Public Contract Code Section 20104.4 to mediate after litigation has been commenced.

#### **14.4.4 Binding Arbitration.**

If the Contract Dispute is not resolved by mediation, then the party wishing to further pursue resolution or determination of the Contract Dispute shall submit the Contract Dispute for final and binding arbitration pursuant to the provisions of California Public Contract Code Sections 10240, et seq. The award of the arbitrator therein shall be final and may be entered as a judgment by any court of competent jurisdiction. Such arbitration shall be conducted in accordance with the following:

- .1 Arbitration Initiation.** The arbitration shall be initiated by filing a complaint in arbitration in accordance with the regulations promulgated pursuant to California Public Contract Code Section 10240.5.
- .2 Qualifications of the Arbitrator.** The arbitrator shall be selected based by mutual agreement of the parties. The arbitrator shall be a retired judge or an attorney with at least five (5) years of experience with public works construction contract law and in arbitrating public works construction disputes. In addition, the arbitrator shall have at least twenty (20) hours of formal training in arbitration skills. In the event the parties cannot agree upon a mutually acceptable arbitrator, then the provisions of California Public Contract Code Section 10240.3 shall be followed in selecting an arbitrator possessing the qualifications required herein.
- .3 Hearing Days and Location.** Arbitration hearings shall be held at the offices of District and shall, except for good cause shown to and

determined by the arbitrator, be conducted on consecutive business days, without interruption or continuance.

- .4 **Hearing Delays.** Arbitration hearings shall not be delayed except upon good cause shown.
- .5 **Recording Hearings.** All hearings to receive evidence shall be recorded by a certified stenographic reporter, with the costs thereof borne equally by District and Contractor and allocated by the arbitrator in the final award.
- .6 **Limitation of Depositions.** Discovery shall be permitted in accordance with the provisions of section 10240.11 of the Public Contract Code; provided, however, that depositions shall be limited to both of the following:
  - (i) Ten (10) percipient witnesses for District and ten (10) percipient witnesses for Contractor; and
  - (ii) Expert witnesses.

Upon a showing of good cause, the arbitrator may increase the number of permitted depositions. An individual who is both percipient and expert shall, for purposes of applying the foregoing numerical limitation only, be deemed an expert. Expert reports shall be exchanged prior to receipt of evidence, in accordance with the direction of the arbitrator, and expert reports (including initial and rebuttal reports) not so submitted shall not be admissible as evidence

- .7 **Authority of the Arbitrator.** The arbitrator shall have the authority to hear dispositive motions and issue interim orders and interim or executory awards.
- .8 **Waiver of Jury Trial.** Contractor and District each voluntarily waives its right to a jury trial with respect to any Contract Dispute that is subject to binding arbitration in accordance with the provisions of this Paragraph 14.4.4. Contractor shall include this provision for waiver of jury trial, waiving the right to jury trial in any action involving District as a party in its contracts with its Subcontractors who provide any portion of the Work.

#### 14.5 Non-Waiver.

There shall be no waiver of the rights granted pursuant to the Dispute Resolution Process, unless specifically set forth in Public Contract Code Section 9204((f)(1) or (2). Specifically, participation in the Contract Dispute Resolution Process shall not constitute a waiver, release or compromise of any defense of District, including, without limitation, any defense based on the assertion that the rights or Claims of Contractor that are the basis of a Contract Dispute were previously waived by Contractor due to failure to comply with the Contract Documents, including, without limitation, Contractor's failure to comply with any time periods for providing notice of requests for adjustments of the Contract Sum or Contract Time or for submission of Claims or supporting documentation of Claims.

---

**SECTION 15            DEFAULT.****15.1    Notice of Default.**

In the event that District determines, in its sole discretion, that Contractor has failed or refused to perform any of the obligations set forth in the Contract Documents, or is in breach of any provision of the Contract Documents, District may give written notice of default to Contractor in the manner specified for the giving of notices in the Construction Contract.

**15.2    Opportunity to Cure Default.**

Except for emergencies, Contractor shall cure any default in performance of its obligations under the Contract Documents within two (2) Days after receipt of written notice. However, if the breach cannot be reasonably cured within such time, Contractor will commence to cure the breach within two (2) Days and will diligently and continuously prosecute such cure to completion within a reasonable time, which shall in no event be later than ten (10) Days after receipt of such written notice.

**SECTION 16            DISTRICT'S RIGHTS AND REMEDIES.****16.1    Remedies Upon Default.**

In the event that Contractor fails to cure any default of this Construction Contract within the time period set forth above in Section 15, then District may pursue any remedies available under law or equity, including, without limitation, the following:

**16.1.1    Delete Certain Services.**

District may, without terminating the Construction Contract, delete certain portions of the Work, reserving to itself all rights to Losses related thereto.

**16.1.2    Perform and Withhold.**

District may, without terminating the Construction Contract, engage others to perform the Work or portion of the Work that has not been performed by Contractor and withhold the cost thereof to District from future payments to Contractor, reserving to itself all rights to Losses related thereto.

**16.1.3    Suspend the Construction Contract.**

District may, without terminating the Construction Contract and reserving to itself all rights to Losses related thereto, suspend all or any portion of this Construction Contract for as long a period of time as District determines, in its sole discretion, appropriate, in which event District shall have no obligation to adjust the Contract Sum or Contract Time, and shall have no liability to Contractor for damages if District directs Contractor to resume Work.

**16.1.4    Terminate the Construction Contract for Default.**

District may terminate all or any part of this Construction Contract for default in accordance with Paragraph 16.4 below, reserving to itself all rights to Losses related thereto and any other damages proximately caused or resulting from the Default.

**16.1.5 Invoke the Performance Bond.**

District may, with or without terminating the Construction Contract and reserving to itself all rights to Losses related thereto, exercise its rights under the Performance Bond.

**16.1.6 Additional Provisions.**

All of District's rights and remedies under this Construction Contract are cumulative and shall be in addition to those rights and remedies available in law or in equity. Designation in the Contract Documents of certain breaches as material shall not be construed as implying that other breaches not so designated are not material nor shall such designations be construed as limiting District's right to terminate the Construction Contract, or the exercise of its other rights or remedies for default, to only material breaches. District's determination of whether there has been noncompliance with the Construction Contract so as to warrant exercise by District of its rights and remedies for default under the Construction Contract, shall be binding on all parties. No termination or action taken by District after such termination shall prejudice any other rights or remedies of District provided by law or equity or by the Contract Documents upon such termination; and District may proceed against Contractor to recover all liquidated damages and Losses suffered by District.

**16.2 Delays by Sureties.**

Without limitation to any of District's other rights or remedies under the law, District has the right to suspend the performance by Contractor's sureties in the event of any of the following:

- (i) Failure of the sureties to begin Work within a reasonable time in such manner as to insure full compliance with the Construction Contract within the Contract Time;
- (ii) Abandonment of the Work;
- (iii) If at any time District is of the opinion the Work is unnecessarily or unreasonably delayed;
- (iv) Willful violation of any terms of the Construction Contract;
- (v) Failure to perform according to the Contract Documents; or
- (vi) Failure to follow instructions of District for its completion within the Contract Time.

District will serve notice of such failure upon the sureties and in the event the sureties neglect or refuse to cure the breach within the time specified in such notice, District shall have the power to suspend the performance or any part thereof of the sureties.

**16.3 Damages to District.****16.3.1 For Contractor's Default.**

District will be entitled to recovery of all Losses under law or equity in the event of Contractor's default under the Contract Documents.

**16.3.2 Compensation for Losses.**

In the event that District's Losses arise from Contractor's default under the Contract Documents, District shall be entitled to withhold monies otherwise payable to Contractor until Final Completion of the Project. If District incurs Losses due to Contractor's default, then the amount of Losses shall be deducted from the amounts withheld. Should the amount withheld exceed the amount deducted, the balance will be paid to Contractor or its designee upon Final Completion of the Project. If the Losses incurred by District exceed the

amount withheld, Contractor shall be liable to District for the difference and shall promptly remit same to District.

#### **16.4 Termination of the Construction Contract for Default.**

Without limitation to any of District's other rights or remedies at law or in equity, and reserving to itself all rights to Losses related thereto, District shall have the right to terminate this Construction Contract, in whole or in part, upon the failure of Contractor to promptly cure any default as required by Section 15. District's election to terminate the Construction Contract for default shall be communicated by giving Contractor a written notice of termination in the manner specified for the giving of notices in the Construction Contract. Any notice of termination given to Contractor by District shall be effective immediately, unless otherwise provided therein.

#### **16.5 Suspension by District for Convenience.**

District may, at any time and from time to time, without cause, order Contractor, in writing, to suspend, delay, or interrupt the Work in whole or in part for such period of time, up to an aggregate of fifty percent (50%) of the Contract Time, as District may determine, with such period of suspension to be computed from the date of the written order. Such order shall be specifically identified as a Suspension Order by District. Upon receipt of a Suspension Order, Contractor shall, at District's expense, comply with its terms and take all reasonable steps to minimize costs allocable to the Work covered by the Suspension Order during the period of Work stoppage. Within the period of the above noted aggregate time, or such extension to that period as is agreed upon by Contractor and District, District shall either cancel the Suspension Order or delete the Work covered by such Suspension Order by issuing a Change Order. If a Suspension Order is canceled or expires, Contractor shall resume and continue with the Work. A Change Order will be issued to cover any adjustments of the Contract Sum or the Contract Time necessarily caused by such suspension. The provisions of this Paragraph 16.5 shall not apply if a Suspension Order is not issued by District. A Suspension Order shall not be required to stop the Work as permitted or required under any other provision of the Contract Documents.

#### **16.6 Termination Without Cause.**

District shall have the option, at its sole discretion and without cause, of terminating this Construction Contract in part or in whole by giving thirty (30) Days written notice to Contractor. Contractor agrees to accept such sums as allowed under this Paragraph 16.6 as its sole and exclusive compensation and waives any claim for other compensation or Losses, including, but not limited to, loss of anticipated profits, loss of revenue, lost opportunity, or other consequential, direct, indirect, or incidental damages of any kind.

##### **16.6.1 Compensation.**

Following such termination and within forty-five (45) Days after receipt of a billing from Contractor seeking payment of sums authorized by this Paragraph 16.6, District shall pay to Contractor as its sole compensation for performance of the Work the following:

- .1 For Work Performed.** The amount of the Contract Sum allocable to the portion of the Work properly performed by Contractor as of the date of termination, less sums previously paid to Contractor.
- .2 For Close-out Costs.** Reasonable costs of Contractor and its Subcontractors and Sub-subcontractors for:
  - (i) Demobilizing and

- (ii) Administering the close-out of its participation in the Project (including, without limitation, all billing and accounting functions, not including attorney or expert fees) for a period of no longer than thirty (30) Days after receipt of the notice of termination in an amount not to exceed the daily sum payable to Contractor for Compensable Delays in Paragraph 6.6 of this Construction Contract.

- .3 **For Fabricated Items.** Previously unpaid cost of any items delivered to the Project Site which were fabricated for subsequent incorporation in the Work.

#### **16.6.2 Subcontractors.**

Contractor shall include provisions in all of its subcontracts, purchase orders and other contracts permitting termination for convenience by Contractor on terms that are consistent with this Construction Contract and that afford no greater rights of recovery against Contractor than are afforded to Contractor under this Section 16.6.

### **16.7 Contractor's Duties Upon Termination.**

Upon receipt of a notice of termination for default or for convenience, Contractor shall, unless the notice directs otherwise, do the following:

- (i) Immediately discontinue the Work to the extent specified in the notice;
- (ii) Place no further orders or subcontracts for materials, equipment, services or facilities, except as may be necessary for completion of such portion of the Work as is not discontinued;
- (iii) Provide to District a description, in writing no later than fifteen (15) days after receipt of the notice of termination, of all subcontracts, purchase orders and contracts that are outstanding, including, without limitation, the terms of the original price, any changes, payments, balance owing, the status of the portion of the Work covered and a copy of the subcontract, purchase order or contract and any written changes, amendments or modifications thereto, together with such other information as District may determine necessary in order to decide whether to accept assignment of or request Contractor to terminate the subcontract, purchase order or contract;
- (iv) Promptly assign to District those subcontracts, purchase orders or contracts, or portions thereof, that District elects to accept by assignment and cancel, on the most favorable terms reasonably possible, all subcontracts, purchase orders or contracts, or portions thereof, that District does not elect to accept by assignment; and
- (v) Thereafter do only such Work as may be necessary to preserve and protect Work already in progress and to protect materials, plants, and equipment on the Project Site or in transit thereto.

## **SECTION 17 CONTRACTOR'S RIGHTS AND REMEDIES.**

### **17.1 Contractor's Remedies.**

Contractor may terminate this Construction Contract for cause only upon the occurrence of one of the following:

#### **17.1.1 For Work Stoppage.**

The Work is stopped for sixty (60) consecutive Days, through no act or fault of Contractor, any Subcontractor, or any employee or agent of Contractor or any Subcontractor, due to issuance of an order of a court or other public authority other than District having jurisdiction or due to an act of government, such as a declaration of a national emergency making material unavailable.

**17.1.2 For District's Non-Payment.**

If District does not make payment of sums that are not in good faith disputed by District and does not cure such default within ninety (90) Days after receipt of notice from Contractor, then upon an additional thirty (30) Days' notice to District, Contractor may terminate the Construction Contract.

**17.2 Damages to Contractor.**

In the event of termination for cause by Contractor, District shall pay Contractor the sums provided for in Paragraph 16.6 above. Contractor agrees to accept such sums as its sole and exclusive compensation and agrees to waive any claim for other compensation or Losses, including, but not limited to, loss of anticipated profits, loss of revenue, lost opportunity, or other consequential, direct, indirect, and incidental damages, of any kind.

**SECTION 18 ACCOUNTING RECORDS.**

**18.1 Financial Management and District Access.**

Contractor shall keep full and detailed accounts and exercise such controls as may be necessary for proper financial management under this Construction Contract in accordance with generally accepted accounting principles and practices consistently applied. District and District's accountants shall be afforded access at all times during normal business hours, to inspect, audit and copy Contractor's records, books, estimates, take-offs, cost reports, ledgers, schedules, correspondence, instructions, drawings, receipts, subcontracts, purchase orders, vouchers, memoranda and other data relating to this Project, and Contractor shall preserve these for a period of three (3) years after the later of (i) final payment or (ii) final resolution of all Contract Disputes and other disputes or for such longer period as may be required by law.

**18.2 Compliance with District Requests.**

Contractor's compliance with any request by District pursuant to this Section 18 shall be a condition precedent to filing or maintenance of any legal action or proceeding by Contractor against District and to Contractor's right to receive further payments under the Contract Documents. Any failure by Contractor to provide access to its business records for inspection or copying by District shall be specifically enforceable by issuance of a writ or a provisional or permanent mandatory injunction by a court of competent jurisdiction based on affidavits submitted to such court, without the necessity of oral testimony.

**SECTION 19 INDEPENDENT PARTIES.**

Both parties to this Construction Contract will be acting in an independent capacity and not as agents, employees, partners, or joint venturers of one another. District, its officers or employees shall have no control over the conduct of Contractor or its respective agents, employees,

Contract No. 2023-03

Water Storage Tank Rehabilitation

subconsultants, or subcontractors, except as herein set forth.

**SECTION 20            NUISANCE.**

Contractor shall not maintain, commit, nor permit the maintenance or commission of any nuisance in connection with the performance of services under this Construction Contract.

**SECTION 21            PERMITS AND LICENSES.**

Contractor, at its sole expense, shall obtain and maintain during the term of this Construction Contract, all appropriate permits, licenses, and certificates that may be required in connection with the performance of services hereunder.

**SECTION 22            WAIVER.**

A waiver by District of any breach of any term, covenant, or condition contained herein shall not be deemed to be a waiver of any subsequent breach of the same or any other term, covenant, or condition contained herein, whether of the same or a different character.

**SECTION 23            CONFLICTS WITH THE CONSTRUCTION CONTRACT.**

District and Contractor agree that if there is any conflict between the terms of this Construction Contract and the other Contract Documents, this Construction Contract shall control.

**SECTION 24            GOVERNING LAW AND VENUE.**

This Construction Contract shall be construed in accordance with and governed by the laws of the State of California. Any and all legal proceedings, including but not limited to mediations, arbitrations, and/or Civil Actions shall be commenced and maintained in the County of San Luis Obispo.

**SECTION 25            COMPLETE AGREEMENT.**

This Construction Contract represents the full and complete understanding of every kind or nature between the parties with respect to the services set forth in this Construction Contract, and all preliminary negotiations and contracts of whatever kind or nature are merged herein. No verbal agreed or implied covenant shall be held to vary the provisions of this Construction Contract. Any modification of this Construction Contract will be effective only upon written execution signed by both District and Contractor and approved as to form by District Legal Counsel.

**SECTION 26            SURVIVAL OF CONTRACT.**

The provisions of the Construction Contract which by their nature survive termination of the Construction Contract or Final Completion, including, without limitation, all warranties, indemnities, payment obligations, and District's right to audit Contractor's books and records,



shall remain in full force and effect after Final Completion or any termination of the Construction Contract.

## **SECTION 27            ADDITIONAL CONTRACT REQUIREMENTS.**

**This contract ( does or  does not) have special fund(s) involved requiring additional contract requirements, therefore this section ( does or  does not) apply.**

This Contract includes the following source of fund(s) or the District intends to apply to the following source of fund(s) for reimbursement of the expenses associated with the work set forth in this Contract:

This Contract includes the following agreement that that the contractor must comply with applicable sections and/or obtain:

- Federal Award Identification #B-22-UC-06-0508 (2022 Community Development Block Grant Funds)
- Federal Labor Standards Provisions – U.S. Department of Housing and Urban Development Office of Davis-Bacon and Labor Standards
- Contract Work Hours and Safety Standards Act
- Copeland “Anti-Kickback” Act
- Code of Federal Regulations – Title 24 Housing and Urban Development
- Requirements For Affirmative Action to Ensure Employment Opportunity (Executive Order 11246)
- Civil Rights, Employment and Contracting Opportunities and Other Federal requirements
- The Davis-Bacon Act
- Davis-Bacon Requirement – Posting The Wage Decision and Notice to Employees
- The Davis-Bacon Act – Jobsite Poster (English and Spanish)
- Davis- Bacon Labor Standards
- The General Decision Number: CA20230012 10/16/2023

District shall require Contractor to comply with the special requirements (Exhibit “H”), as they may be amended from time to time, in addition to all other requirements imposed by District.

**This contract ( does or  does not) have permit(s) obtained by the District, or which the contractor must obtain, requiring additional contract requirements, therefore this section ( does or  does not) apply.**

This Contract includes the following permits that that the contractor must comply with and/or obtain:

N/A

District shall require Contractor to comply with the special requirements (Exhibit “H”), as they may be amended from time to time, in addition to all other requirements imposed by District.

## **SECTION 28                      SPECIFIC REQUIREMENTS FOR PUBLIC WORKS CONTRACTORS**

California state law creates specific requirements for contractors for a public works project. In addition to the general requirement in Section 10 of this Agreement, Contractor specifically acknowledges and agrees to comply with the following provisions of state law:

- California S.B. 854 and associated requirements and regulations by the Department of Industrial Relations, including:
  - No contractor or subcontractor may be listed on a bid proposal for a public works project (submitted on or after March 1, 2015) unless registered with the Department of Industrial Relations pursuant to Labor Code section 1725.5 [with limited exceptions from this requirement for bid purposes only under Labor Code section 1771.1(a)].
  - No contractor or subcontractor may be awarded a contract for public work on a public works project (awarded on or after April 1, 2015) unless registered with the Department of Industrial Relations pursuant to Labor Code section 1725.5. Contractors MUST be a registered “public works contractor” with the DIR AT THE TIME OF BID. Where the prime contract is less than \$15,000 for maintenance work or less than \$25,000 for construction alternation, demolition or repair work, registration is not required.
  - This project is subject to compliance monitoring and enforcement by the Department of Industrial Relations.
- Labor Code § 1770, et seq., regarding prevailing wage requirements established and issued by the Department of Industrial Relations, Division of Labor Statistics and Research.
- Labor Code § 1776, regarding maintenance and submission of accurate payroll records of trades workers on all public works projects and furnishing electronic certified payroll records to the state Labor Commissioner.
- Labor Code § 1777.5, regarding apprenticeable occupations, including employing only registered apprentices on this Project. This Agreement fixes the responsibility of compliance with § 1777.5 for all apprenticeable occupations with the prime Contractor.
- Labor Code § 1813, regarding forfeiting to the District the statutory amount for each worker employed in the execution of this Contract by Contractor or by any subcontractor for each calendar day during which such worker is required or permitted to work more than eight (8) hours in any one calendar day and forty (40) hours in any one calendar week in violation of the provisions of Section 1810, et seq., of the California Labor Code.
- Labor Code §§ 1860, 1861, and 3700, requiring the Contractor and each subcontractor to agree to secure the payment of compensation to his or her employees. In accordance with state law, Contractor acknowledges that they are aware of the provisions of Section 3700 of the Labor Code which require every employer to be insured against liability for workers’ compensation or to undertake self-insurance in accordance with the provisions of that code and will comply with such provisions before commencing the performance of the work of this contract.

Federal law creates specific requirements for contractors for a public works project. In addition to the general requirement in Section 10 of this Agreement, Contractor specifically acknowledges and agrees to comply with the following Davis-Bacon provisions of federal law. See Exhibit “H” -

- Federal Labor Standards Provisions – U.S. Department of Housing and Urban Development Office of Davis-Bacon and Labor Standards
- Contract Work Hours and Safety Standards Act
- Copeland “Anti-Kickback” Act

- Code of Federal Regulations – Title 24 Housing and Urban Development
- Requirements For Affirmative Action to Ensure Employment Opportunity (Executive Order 11246)
- Civil Rights, Employment and Contracting Opportunities and Other Federal requirements
- The Davis-Bacon Act
- Davis-Bacon Requirement – Posting The Wage Decision and Notice to Employees
- The Davis-Bacon Act – Jobsite Poster (English and Spanish)
- Davis- Bacon Labor Standards
- The General Decision Number: CA20230012 10/16/2023

The District for which work is being performed or the California Department of Industrial Relations may impose penalties upon contractor and subcontractors for failure to comply with prevailing wage requirements. These are up to \$200.00 per day per worker for each age violation identified; \$100.00 per day worker for failure to provide the required paperwork and documentation requested within a 10-day window; and \$25 per day per worker for any overtime violation.

The District shall withhold any portion of a payment, including the entire payment amount, until certified payroll forms and related documentation are properly submitted, reviewed and found to be in full compliance. In the event that certified payroll forms do not comply with the requirements of the Labor Code Section 1720 et seq., the District may continue to hold sufficient fund to cover estimated wages and penalties under the contract.

As of April 1, 2015, contractors and subcontractors must furnish electronic certified payroll records to the Labor Commissioner (State of California, Division of Labor Standards Enforcement).

The applicable California prevailing wage rate can be found at [www.dir.ca.gov](http://www.dir.ca.gov) and are on file with the Agency's principal office, which shall be available to any interested party upon request. The contractor is also required to have a copy of the applicable wage determination posted and/or available at each jobsite.

Please see the DIR website for complete details and actions. It is the responsibility of the contractor to ensure all DIR requirements and regulations are met and stay current. For more information on Senate Bill No. 854, see <http://www.dir.ca.gov/Public-Works/SB854.html>.

## **SECTION 29                      GOVERNMENTAL POWERS.**

Nothing in this Agreement shall be deemed directly or indirectly to restrict or to impair in any manner or respect whatsoever any of District's governmental powers or rights or the exercise thereof by District, with respect to the Work or Project.

**SECTION 30 SEVERABILITY.**

In case a provision of this Construction Contract is held to be invalid, illegal, or unenforceable, the validity, legality and enforceability of the remaining provisions shall not be affected.

**SECTION 31 EXHIBITS.**

Exhibit A - Notice Inviting Bids.

Exhibit B - Contractor's Bid.

Exhibit C - General Conditions.

Exhibit D - Special Provisions and/or Technical Specifications & Plans  
and Drawings:

- Advantage Technical Services, Inc – Project Manual for Oceano Community Services District's 0.3 Million Gallon Water Tank Recoating and Roof Replacement Project

Exhibit E - Payment and Performance Bonds.

Exhibit F - Insurance Requirements.

Exhibit G - Rules Governing Bid Protests

Exhibit H - Reports, Supplements, Attachments, Modifications, and Exhibits attached to the above items including:

- Federal Award Identification #B-22-UC-06-0508 (2022 Community Development Block Grant Funds)
- Federal Labor Standards Provisions – U.S. Department of Housing and Urban Development Office of Davis-Bacon and Labor Standards
- Contract Work Hours and Safety Standards Act
- Copeland "Anti-Kickback" Act
- Code of Federal Regulations – Title 24 Housing and Urban Development
- Requirements For Affirmative Action to Ensure Employment Opportunity (Executive Order 11246)
- Civil Rights, Employment and Contracting Opportunities and Other Federal requirements
- The Davis-Bacon Act
- Davis-Bacon Requirement – Posting The Wage Decision and Notice to Employees
- The Davis-Bacon Act – Jobsite Poster (English and Spanish)
- Davis- Bacon Labor Standards
- The General Decision Number: CA20230012 10/16/2023

IN WITNESS WHEREOF, the parties have caused this Construction Contract to be executed the date and year first above written.

**OCEANO COMMUNITY SERVICES DISTRICT**

BY: \_\_\_\_\_  
OCSD Board President

DATE: \_\_\_\_/\_\_\_\_/ 2023

Approved as to FORM:

BY: \_\_\_\_\_  
OCSD Legal Counsel

DATE: \_\_\_\_/\_\_\_\_/ 2023

BY: \_\_\_\_\_  
Contractor

DATE: \_\_\_\_/\_\_\_\_/ 2023

**OCEANO COMMUNITY SERVICES DISTRICT**

**Water Storage Tank Rehabilitation**

**GENERAL CONDITIONS**

**FOR**

**OCEANO, CA**

**CONTRACT NO. 2023-03**

OCEANO COMMUNITY SERVICES DISTRICT

STANDARD CONSTRUCTION CONTRACT GENERAL  
CONDITIONS

## GENERAL CONDITIONS TABLE OF CONTENTS

<b>ARTICLE 1 – GENERAL PROVISIONS .....</b>	<b>5</b>
1.1    DEFINITIONS.....	5
1.2    OWNERSHIP AND USE OF DOCUMENTS .....	15
1.3    AUTHORITY OF DISTRICT.....	16
1.4    INTERPRETATION OF CONTRACT DOCUMENTS.....	16
<b>ARTICLE 2 – DISTRICT .....</b>	<b>19</b>
2.1    INFORMATION AND SERVICES PROVIDED BY DISTRICT.....	19
2.2    ACCESS TO PROJECT SITE.....	19
2.3    DISTRICT'S RIGHT TO STOP THE WORK.....	19
2.4    DISTRICT'S RIGHT TO CARRY OUT THE WORK.....	20
<b>ARTICLE 3 – CONTRACTOR.....</b>	<b>21</b>
3.1    REVIEW OF THE SITE, CONTRACT DOCUMENTS AND FIELD CONDITIONS.....	21
3.2    SUPERVISION AND CONSTRUCTION PROCEDURES.....	23
3.3    RESPONSIBILITY FOR THE WORK .....	23
3.4    LABOR, WORKMANSHIP, MATERIALS AND MANUFACTURED ITEMS .....	24
3.5    CONTRACTOR'S WARRANTY .....	24
3.6    CONSTRUCTION METHODS AND PROCEDURES.....	24
3.7    TAXES.....	25
3.8    LEGAL REQUIREMENTS.....	25
3.9    SUPERINTENDENT/PROJECT STAFF.....	25
3.10   SCHEDULES REQUIRED OF CONTRACTOR .....	26
3.11   DOCUMENTS AND SAMPLES AT PROJECT SITE.....	28
3.12   SUBMITTALS .....	29
3.13   TRADE NAMES, SUBSTITUTIONS .....	31
3.14   DAILY REPORTS BY CONTRACTOR.....	32
3.15   CUTTING AND PATCHING .....	33
3.16   ACCESS TO THE WORK .....	33
3.17   ROYALTIES AND PATENTS .....	33
3.18   PERMITS AND LICENSES.....	34
3.19   DIFFERING SITE CONDITIONS.....	34
3.20   INSPECTIONS.....	35
3.21   INDEMNIFICATION, STOP NOTICES.....	36
3.22   PARKING .....	36



3.23	<i>USE OF THE PROJECT SITE AND CLEAN UP</i> .....	36
3.24	<i>ENVIRONMENTAL CONTROLS</i> .....	37
<b>ARTICLE 4 – ADMINISTRATION OF THE CONTRACT</b> .....		<b>44</b>
4.1	<i>CONTRACT ADMINISTRATION BY DISTRICT, DESIGN CONSULTANT AND CONSTRUCTION MANAGER</i> .....	44
4.2	<i>CLAIMS</i> .....	45
<b>ARTICLE 5 – SUBCONTRACTORS</b> .....		<b>51</b>
5.1	<i>CONTRACTOR'S AWARD OF SUBCONTRACTS</i> .....	51
5.2	<i>SUBCONTRACTUAL RELATIONS</i> .....	52
5.3	<i>CONTINGENT ASSIGNMENT OF SUBCONTRACTS</i> .....	54
<b>ARTICLE 6 – CONSTRUCTION BY DISTRICT OR BY SEPARATE CONTRACTORS</b> .....		<b>55</b>
6.1	<i>DISTRICT'S RIGHT TO PERFORM CONSTRUCTION AND TO AWARD SEPARATE CONTRACTS</i> .....	55
6.2	<i>MUTUAL RESPONSIBILITY</i> .....	55
6.3	<i>DISTRICT'S RIGHT TO CLEAN UP</i> .....	56
<b>ARTICLE 7 – CHANGES</b> .....		<b>57</b>
7.1	<i>CHANGES</i> .....	57
7.2	<i>CHANGE ORDERS AND CHANGE ORDER REQUESTS</i> .....	58
7.3	<i>FIELD ORDERS</i> .....	64
7.4	<i>DISPUTES REGARDING CHANGES</i> .....	64
<b>ARTICLE 8 – CONTRACT TIME</b> .....		<b>65</b>
8.1	<i>COMMENCEMENT OF THE WORK</i> .....	65
8.2	<i>PROGRESS AND COMPLETION</i> .....	65
8.3	<i>DELAY</i> .....	66
<b>ARTICLE 9 – PAYMENTS AND COMPLETION</b> .....		<b>69</b>
9.1	<i>SCHEDULE OF VALUES</i> .....	69
9.2	<i>PROGRESS PAYMENT</i> .....	69
9.3	<i>APPLICATION FOR PAYMENT</i> .....	70
9.4	<i>CERTIFICATE FOR PAYMENT</i> .....	71
9.5	<i>DEPOSIT OF SECURITIES IN LIEU OF RETENTION AND DEPOSIT OF RETENTION INTO ESCROW</i> .....	73
9.6	<i>BENEFICIAL OCCUPANCY/BENEFICIAL USE</i> .....	73
9.7	<i>SUBSTANTIAL COMPLETION</i> .....	75
9.8	<i>FINAL COMPLETION AND FINAL PAYMENT</i> .....	75
<b>ARTICLE 10 – PROTECTION OF PERSONS AND PROPERTY</b> .....		<b>77</b>
10.1	<i>SAFETY PRECAUTIONS AND PROGRAMS</i> .....	77
10.2	<i>SAFETY OF PERSONS AND PROPERTY</i> .....	77

(v) General Conditions

---

10.3	<i>EMERGENCIES</i> .....	79
<b>ARTICLE 11 – INSURANCE AND BONDS</b> .....		<b>80</b>
11.1	<i>CONTRACTOR'S INSURANCE</i> .....	80
11.2	<i>BOND REQUIREMENTS</i> .....	80
<b>ARTICLE 12 – DEFECTIVE WORK</b> .....		<b>82</b>
12.1	<i>UNCOVERING OF WORK</i> .....	82
12.2	<i>CORRECTION OF DEFECTIVE WORK AND GUARANTEE TO REPAIR PERIOD</i> .....	82
12.3	<i>ACCEPTANCE OF DEFECTIVE WORK</i> .....	84
<b>ARTICLE 13 – STATUTORY REQUIREMENTS</b> .....		<b>85</b>
13.1	<i>NONDISCRIMINATION/EQUAL OPPORTUNITY</i> .....	85
13.2	<i>STATE LABOR LAW</i> .....	87
13.3	<i>PAYROLL RECORDS</i> .....	88
13.4	<i>APPRENTICES</i> .....	89
13.5	<i>WORK DAY</i> .....	89

## **ARTICLE 1 – GENERAL PROVISIONS**

### **1.1 DEFINITIONS**

Terms appearing in the Contract Documents with initial capitalization shall have the meanings set forth below:

1.1.1 **ACCEPTANCE:** The point after Final Completion when Contractor has fully performed all of the requirements of the Contract Documents and the Work is accepted by District in writing.

1.1.2 **ADDENDA, ADDENDUM:** Written or graphic information (including, without limitation, Drawings or Special Provisions and Technical Specifications) prepared and issued by District General Manager or its designee prior to the receipt of Contractor's Bid, which modify or interpret the Bid Documents by additions, deletions, clarifications, or corrections.

1.1.3 **ALLOWABLE COSTS:** Costs for which reimbursement is allowed under Article 7.2.5 of these General Conditions and for which reimbursement is allowed under other provisions of the Contract Documents, that may be added by Change Order to the Contract Sum for Extra Work or deducted by Change Order from the Contract Sum for Deleted Work.

1.1.4 **ALTERNATE(S):** Those portions of the Bid setting forth the price(s) for optional or alternative items of Work not covered by the Base Bid.

1.1.5 **APPLICABLE CODE REQUIREMENTS:** All applicable federal, state, and municipal laws, statutes, building codes, ordinances and regulations of governmental authorities having jurisdiction over the Project, Work, Site, Contractor or District.

1.1.6 **APPLICATION FOR PAYMENT:** An itemized application for payment prepared and submitted by Contractor for review and approval by District, which is prepared, submitted, and accompanied by supporting documentation in accordance with the requirements of the Contract Documents.

1.1.7 **APPROVE, APPROVED or APPROVAL:** Whether capitalized or not capitalized, shall mean, unless otherwise stated, either an express approval contained in a written statement signed by the approving individual or entity or deemed approved in accordance with the terms, conditions and procedures set forth in the Contract Documents. All such approvals by or on behalf of District (including, without limitation, approvals by Construction Manager) may be granted or withheld in the sole discretion of District.

1.1.8 **AS-BUILT DOCUMENTS:** The Contract Documents showing the condition of the Work as actually built, including, without limitation, the locations of

mechanical, electrical, plumbing, HVAC or similar portions of the Work that are shown diagrammatically in the Contract Documents approved by District. These documents are maintained by Contractor on the Site and delivered, along with an electronic version of the set, to District upon Final Completion.

1.1.9 BASE BID: The sum stated in the Bid to perform the Work, exclusive of any Alternate(s).

1.1.10 BENEFICIAL OCCUPANCY: District's right, at its option and convenience, to occupy or otherwise make use of all or any part of the Work prior to either Substantial Completion, Final Completion, or Acceptance.

1.1.11 BID: Contractor's written bid proposal submitted to District for the Project in response to District's Notice Inviting Bids.

1.1.12 BID DOCUMENTS: The following collection of documents are designated as the Bid Documents:

- (i) Notice Inviting Bids.
- (ii) Instructions to Bidders.
- (iii) Blank Bid Form.
- (iv) Construction Contract between District and Contractor.
- (v) General Conditions.
- (vi) Special Provisions and Technical Specifications.
- (vii) Plans and Drawings.
- (viii) Bidding Addenda.
- (ix) Reports, Supplements, Attachments, Modifications, and Exhibits attached to the above items.

1.1.13 CERTIFICATE FOR PAYMENT: The form for approval by the Construction Manager of Contractor's Application for Payment.

1.1.14 CHANGE: Whether capitalized or not, when used in reference to changes in the Work is a generic term encompassing additions, deletion, alterations, or changes in the Work, which may or may not involve Extra Work and for which Contractor may or may not be entitled to a Change Order under the terms of the Contract Documents.

1.1.15 CHANGE ORDER: A written instrument signed by District, or by District and  
(v) General Conditions

Contractor, describing a Change to the Work of Contractor.

1.1.16 CHANGE ORDER REQUEST: Contractor's written request for an adjustment in the Contract Sum or Contract Time due to a Change resulting in Extra Work or Deleted Work.

1.1.17 DISTRICT: Oceano Community Services District, a California special district.

1.1.18 CONTRACTOR CLAIM: A separate demand by a Contractor sent by registered mail or certified mail, with return receipt requested, for one or more of the following: (A) a time extension, including, without limitation, for relief from damages or penalties for delay assessed by the District; (B) payment by the District of money or damages arising from work done by, or on behalf of, the Contractor pursuant to the Construction Contract and payment for which is not otherwise expressly provided or to which the claimant is not otherwise entitled; (C) payment of an amount that is disputed by the District. A Contractor Claim does not include, and the procedures for processing of Contractor Claims do not apply to the following:

- (i) Penalties or forfeitures prescribed by statute or regulation imposed by a governmental agency other than penalties for delay assessed by the District pursuant to Section 1.1.18(B);
- (ii) Tort claims for personal injury or death;
- (iii) False claims liability under California Government Code Section 12650, et seq.;
- (iv) Defects in the Work first discovered by District after final payment by District to Contractor;
- (v) Stop notices;
- (vi) The right of District to specific performance or injunctive relief to compel performance of any provision of the Contract Documents or for other District claims against the Contractor.

1.1.19 COMPENSABLE DELAY: A Delay for which Contractor may be entitled under the Contract Documents to both an extension of the Contract Time and an adjustment of the Contract Sum for additional compensation. "Compensable Delay" means any Delay to the path of activities that is critical to Contractor's Substantial Completion of the Work within the Contract Time, which Delay is all of the following:

- (i) Solely due to Changes requested by District that adds time but does not involve Extra Work.
- (ii) Not due, in whole or in part, to the fault or negligence or breach of Contractor or any Subcontractor or Sub-subcontractor, of any Tier.
- (iii) Not concurrent with another Excusable Delay or any Unexcused Delay.

1.1.20 CONSTRUCTION CONTRACT: The written contract executed between District and Contractor for construction of the Project.

1.1.21 CONSTRUCTION MANAGER: The District General Manager or any person designated by the District General Manager or District Board to oversee the Project. The Construction Manager can be an individual, partnership, corporation, joint venture, or other legal entity under contract with District to perform construction management services for the Project. The term "Construction Manager" means Construction Manager or Construction Manager's authorized representative.

1.1.22 CONSTRUCTION SCHEDULE: The graphical representation of Contractor's as-planned schedule for performance of the Work, prepared in accordance with the requirements of the Contract Documents and that provides for Substantial Completion of the Work within the Contract Time.

1.1.23 CONTRACT DISPUTE: A dispute, other than a dispute listed in Section 14.2.1 (Non-Contract Disputes) of the Construction Contract, arising out of or related to the Construction Contract or the interpretation, enforcement, or breach thereof.

1.1.24 CONTRACT DISPUTE RESOLUTION PROCESS: The process of resolution of Contract Disputes, and, upon election of District, disputes as set forth in Section 14 (Dispute Resolution) of the Construction Contract.

1.1.25 CONTRACT DOCUMENTS: The following collection of documents are designated as contract documents:

- (i) The Notice Inviting Pre-Qualification Statements, Pre-Qualification Statement, and Pre-Qualification Checklist (if applicable).
- (ii) Executed Construction Contract between District and Contractor.
- (iii) Notice Inviting Bids.
- (iv) Instructions to Bidders.
- (v) General Conditions

- (v) Bidding Addenda.
- (vi) Contractor's Bid.
- (vii) General Conditions.
- (viii) Special Provisions and Technical Specifications.
- (ix) Performance and Payment Bonds.
- (x) Insurance Forms.
- (xi) Plans and Drawings.
- (xii) Reports listed in the Bidding Documents.
- (xiii) Supplements, Attachments and Exhibits attached to the above items.
- (xiv) Modifications.
- (xv) Change Orders.
- (xvi) Field Orders.
- (xvii) Other Documents if so designated by written agreement of the Parties.

1.1.26 CONTRACT SUM: The total amount of compensation stated in the Construction Contract that is payable to Contractor for the performance of the Work in accordance with the Contract Documents.

1.1.27 CONTRACT TIME: The total number of days set forth in the Construction Contract within which Substantial Completion of the Work must be achieved by Contractor, including approved extensions of time permitted under the terms of the Contract Documents.

1.1.28 CONTRACTOR: The individual or firm under contract with District to serve as the General Contractor for construction of the Project. The term "Contractor" means Contractor or Contractor's authorized representative.

1.1.29 CONTRACTOR MARKUP: The additional sum or deductive credit provided for under the Construction Contract for Contractor's profit and overhead on Extra or Deleted Work for which a Change Order is required to be executed under the Contract Documents adjusting the Contract Sum.

1.1.30 DAY: Whether capitalized or not, unless otherwise specifically provided, means calendar day. NOTE: For Federally-funded projects DAY, whether capitalized or not, is considered WORKING DAY and is defined as any day, except weekends and legal holidays.

(v) General Conditions

1.1.31 DEFECTIVE WORK: Work by Contractor that is unsatisfactory, faulty, omitted, incomplete, deficient or does not conform to the Applicable Code Requirements, the Contract Documents, the directives of District or the requirements of any inspection, reference standard, test, code, or approval specified in the Contract Documents.

1.1.32 DELAY: Whether capitalized or not, includes any circumstances involving disruption, hindrance, or interference in the performance of the Work.

1.1.33 DELETED WORK: Work that is eliminated due to a Change in the Work requested by District or Contractor for which District is entitled to a deductive adjustment in the Contract Sum.

1.1.34 DESIGN CONSULTANT. The individual(s) or firm(s) under contract with District to provide design or engineering services for the Project and are responsible for preparing the Contract Documents for the Project. The term "Design Consultant" means Design Consultant or Design Consultant's authorized representative.

1.1.35 DIFFERING SITE CONDITIONS. Differing Site Conditions are those conditions encountered at the Site or in Existing Improvements that are (1) subsurface or concealed conditions which differ materially from those indicated in the Contract Documents; or (2) unknown physical conditions at the Site, of an unusual nature, differing materially from those ordinarily encountered and generally recognized as inherent in the Work of the character provided for in the Contract Documents.

1.1.36 DRAWINGS: The graphic and pictorial portions of the Contract Documents showing the design, location, and dimensions of the Work, generally including plans, elevations, subparagraphs, details, schedules, and diagrams. The Drawings are outlined in the Drawing Index. The term "Drawings" may be used interchangeably with "Plans."

1.1.37 ESCROW AGENT: A state or federally chartered bank in the State of California which holds securities pursuant to an escrow agreement as set forth in Article 9.5 of these General Conditions.

1.1.38 EXCUSABLE DELAY: A Delay for which Contractor may be entitled under the Contract Documents to an extension of time, but not compensation. "Excusable Delay" means any delay to the path of activities that is critical to Substantial Completion of the Work within the Contract Time caused by conditions beyond the control or foreseeability, and without the fault or negligence of Contractor or its Subcontractors or Sub-subcontractors, of any Tier, such as, but not limited to: war, embargoes, fire, unavoidable casualties, unusual delays in transportation, national emergency, and stormy and inclement weather



conditions that are unusual and unseasonable and in which the Work cannot continue. Without limitation to the foregoing, the financial inability of Contractor or any Subcontractor or Sub-subcontractor, shall not be deemed conditions beyond Contractor's control or foreseeability. Contractor may claim an Excusable Delay only if all Work on a critically scheduled activity is stopped for more than six (6) hours of a normal eight (8) hour working day, or if three to six hours are lost in one working day, then it may be claimed for one-half day. A Compensable Delay shall, to the extent that it is concurrent with an Excusable Delay, be conclusively deemed an Excusable Delay.

1.1.39 EXISTING IMPROVEMENTS: All improvements located on the Site as of the date of execution of the Construction Contract, whether above or below the surface of the ground, including but not limited to existing buildings, utilities, infrastructure improvements and other facilities.

1.1.40 EXTRA WORK: Additional Work or costs due to a Change in the Work that is not described in or reasonably inferable from the Contract Documents and for which Contractor is entitled to an adjustment of the Contract Sum under the terms of the Contract Documents. Extra Work shall not include additional Work or costs arising from Contractor's failure to perform any of its duties or obligations under the Contract Documents or arising from errors, omissions, conflicts, ambiguities, lack of coordination or noncompliance with Applicable Code Requirements in the Contract Documents with respect to which Contractor has assumed responsibility in connection with its obligation to conduct a careful review of the Bid Documents and Contract Documents.

1.1.41 FIELD ORDER: A written instrument signed by the Construction Manager that requests performance of Work in one of the following categories:

- (i) Over which there is a dispute as to whether the Work is or is not Extra Work.
- (ii) Involving Extra Work which District requests be performed without a unilateral Change Order adjustment to the Contract Sum or Contract Time and before all terms of an adjustment to the Contract Sum or Contract Time are fully agreed upon by District and Contractor.

The purpose of a Field Order is to direct performance of Work, which may be disputed, and, whether or not it expressly so states, shall not be construed as an acknowledgment by District that the Work described constitutes a Change or Extra Work if that is, in fact, not the case.

1.1.42 FINAL COMPLETION: The point at which:

- (i) Work is completed to the satisfaction of District in accordance with the Contract Documents, including minor corrective or completion items.

(ii) All requirements of the Contract Documents entitling Contractor to final payment shall have been performed by Contractor (including, without limitation, delivery of all warranties and guarantees, equipment operation and maintenance manuals, as-built drawings and schedules and certificates required prior to occupancy).

(iii) All approvals and acceptances shall have been made pursuant to Applicable Code Requirements.

(iv) All rubbish, tools, scaffolding and surplus materials and equipment have been removed from the Site.

1.1.43 FRAGNET: A "Fragnet", sometimes referred to as "time impact analysis," is a contemporaneous, fragmentary scheduling network, which graphically identifies the sequencing of all critical and non-critical new activities and/or activity revisions affected by a Change Order Request, Field Order or Change Order, with logic ties to all affected existing activities noted on the Construction Schedule. Its objective is to isolate and quantify any time impact of a specific issue, determine, and demonstrate any such specific Delay in relation to past and/or other current Delays and to provide a method for incorporating adjustments to the Contract Time into the Construction Schedule.

1.1.44 GENERAL CONDITIONS: That portion of the Contract Documents relating to the administrative procedures to be followed by Contractor in carrying out the Work.

1.1.45 HAZARDOUS SUBSTANCES: Refers to, without limitation, the following: any chemical, material or other substance defined as or included within the definition of hazardous substances, hazardous wastes, extremely hazardous substances, toxic substances, toxic material, restricted hazardous waste, special waste, or words of similar import under any Environmental Law.

1.1.46 LOSSES: Any and all losses, costs, liabilities, Claims, damages, liquidated damages, actions, judgments, settlements, expenses, fines and penalties. "Losses" do not include attorneys' fees.

1.1.47 MODIFICATION: A document other than a Change Order, approved by District Legal Counsel and signed by District or Construction Manager and Contractor, agreeing to alter, amend or modify the Contract Documents.

1.1.48 NON-COMPENSABLE DELAY: An (i) Unexcused Delay; and (ii) an Excusable Delay that is not also a Compensable Delay.

1.1.49 NOTICE OF AWARD: Written notice issued by District notifying Contractor of issuance of the Construction Contract.

1.1.50 NOTICE TO PROCEED: Written notice issued by District to Contractor to

(v) General Conditions

begin the Work.

1.1.51 PERFORMANCE BOND, PAYMENT BOND: The performance and payment bonds to be provided by Contractor for the Project.

1.1.52 PLANS: The graphic and pictorial portions of the Contract Documents showing the design, location, and dimensions of the Work, generally including plans, elevations, subparagraphs, details, schedules and diagrams. The term "Plans" may be used interchangeably with "Drawings."

1.1.53 PRE-CONSTRUCTION MEETING: A meeting held with the Project Team prior to beginning construction in order to review Contract Documents and clarify roles, responsibilities and authority of the Project Team.

1.1.54 PROJECT: The total construction, of which the Work performed by Contractor under the Contract Documents may be the whole or part and which may include Work performed by District's own forces or by Separate Contractors.

1.1.55 PROJECT TEAM: Collectively, the Contractor, District, Design Consultant, Separate Contractors, Construction Manager and other consultants and contractors providing professional and technical consultation for the design and construction of the Project.

1.1.56 RECORD DOCUMENTS: The term "Record Documents" refers to the As-Built Documents, warranties, guarantees, and other documents required to be submitted by Contractor as a condition of Final Completion.

1.1.57 REQUEST FOR INFORMATION: A written instrument, prepared by Contractor, which requests an interpretation or clarification in the Work or a response to a question concerning the Work. A Request for Information does not entitle Contractor to an adjustment in the Contract Sum unless it requires Extra Work and Contractor requests and is entitled to such an adjustment in accordance with the provisions of the Contract Documents.

1.1.58 REQUEST FOR INFORMATION RESPONSE: A written instrument, usually prepared by the Design Consultant, which sets forth an interpretation or clarification in the Work or a response to a Contractor question concerning the Work.

1.1.59 SCHEDULE OF VALUES: A detailed, itemized breakdown of the Contract Sum, which provides for a fair and reasonable allocation of the dollar values to each of the various parts of the Work.

1.1.60 SEPARATE CONTRACTOR: A person or firm under separate contract with District or other entity performing other Work at the Site.

1.1.61 SITE: The physical site located within District where the Project is to be

constructed, including all adjacent areas for staging, storage, parking and temporary offices.

**1.1.62 SPECIAL PROVISIONS AND TECHNICAL SPECIFICATIONS:** The portion of the Contract Documents consisting of the written requirements for materials, equipment, standards, skill, quality for the Work and performance of related services. These provisions may also contain amendments, deletions, or additions to the General Conditions.

**1.1.63 STATEMENT OF CONTRACT DISPUTE:** The Contractor's written statement prepared in accordance with Section 14.3 (Submission of Contractor Claim) of the Construction Contract required as a condition of its initiating the Contract Dispute Resolution Process.

**1.1.64 SUBCONTRACTOR:** A person or firm that has a contract with a Contractor to perform a portion of the Work. The term "Subcontractor" includes suppliers and vendors and is referred to throughout the Contract Documents as if singular in number and means a Subcontractor or an authorized representative of the Subcontractor.

**1.1.65 SUB-SUBCONTRACTOR:** A person or firm that has a contract with a Subcontractor to perform a portion of the Work. The term "Sub-subcontractor" includes suppliers and vendors and is referred to throughout the Contract Documents as if singular in number and means a Sub-subcontractor or an authorized representative of the Sub-subcontractor.

**1.1.66 SUBCONTRACTOR/SUB-SUBCONTRACTOR MARKUPS:** The sum allowable under the Construction Contract for Subcontractor and Sub-subcontractor profit and overhead on Extra or Deleted Work for which Contractor is entitled to a Change Order under the Contract Documents adjusting the Contract Sum.

**1.1.67 SUBMITTALS:** All shop drawings, samples, exemplars, product data and other submittals required to be submitted by Contractor under the Contract Documents.

**1.1.68 SUBSTANTIAL COMPLETION, SUBSTANTIALLY COMPLETE:** The point at which the Work is sufficiently complete to be occupied and/or utilized by District for its intended purpose, and Contractor has fulfilled its obligations under the Contract Documents as determined by District, except for minor punch-list items which do not impair District's ability to so occupy and utilize the Project.

**1.1.69 SUPERINTENDENT:** The person appointed by Contractor, subject to approval by District, to supervise and coordinate Contractor's own forces and Subcontractors in all aspects of the Work.

1.1.70 TIER: The contractual level of a Subcontractor with respect to Contractor. For example, a first-tier Subcontractor is under subcontract with Contractor. A Sub-subcontractor under subcontract with a first-tier Subcontractor, is in the second tier, and so on.

1.1.71 UNEXCUSED DELAY: Any Delay in the path of activities that is critical to Substantial Completion of the Work within the Contract Time resulting from causes other than Excusable Delay or Compensable Delay. An Unexcused Delay shall not entitle Contractor to either an extension of the Contract Time or an adjustment of the Contract Sum. A Compensable Delay or Excusable Delay shall, to the extent it is concurrent with an Unexcused Delay, be conclusively deemed an Unexcused Delay.

1.1.72 WORK: All labor, materials, equipment, services, permits, licenses and taxes, and all other things necessary for Contractor to perform its obligations and complete the Project, including, without limitation, any changes or additions requested by District, in accordance with the Contract Documents and all Applicable Code Requirements.

1.1.73 INTERPRETATION OF “SHALL” AND “MAY.” Where applicable to determine obligations of the Parties, the term “SHALL” is to be construed as mandatory and “MAY” shall be construed as permissive.

## **1.2 OWNERSHIP AND USE OF DOCUMENTS**

1.2.1 All originals, copies and electronic forms of Drawings, Plans, specifications, shop drawings, samples, reports, schedules and other materials or documents prepared for the Project (including, without limitation, the Contract Documents) shall not be used by Contractor, or any Subcontractor or Sub-subcontractor, of any Tier, for any purpose other than performance of the Work. Contractor, Subcontractors and Sub-subcontractors are granted a limited license, revocable at will by District, to use and reproduce applicable portions of the Contract Documents appropriate to and for use in the execution of their Work under the Contract Documents; provided however, that such use shall not be construed in derogation of Owner’s rights to use and ownership under this provision.

1.2.2 Contractor shall keep on the Site of the Project, at all times, a complete set of District approved, permitted Contract Documents for use by District.

1.2.3 Proposed Changes or refinements and clarifications will be provided to Contractor in the form of reproducible prints. Contractor shall, at its own expense and without adjustment to the Contract Sum, do all reproduction and distribution of such reproducible prints as necessary for the complete pricing of the Change and for performance of the Work.

1.2.4 Contractor shall take all necessary steps to assure that a provision is included in all contracts with Subcontractors and Sub-subcontractors, of every

Tier, who perform Work on the Project, protecting and preserving District's rights to ownership and use of documents as set forth in this Article 1.2.

1.2.5 All documents, including but not limited to Drawings, Plans, specifications, shop drawings, samples, reports, schedules and other materials or documents prepared for the Project (including, without limitation, the Contract Documents) shall be owned exclusively by the District prior to and after completion of the Project.

### **1.3 AUTHORITY OF DISTRICT**

1.3.1 The Design Consultant shall, upon request, make recommendations to District and the Construction Manager concerning the quality or acceptability of Work performed.

1.3.2 District, in its sole discretion, will interpret the Contract Documents and make the determination of whether or not Contractor has fulfilled the requirements of the Contract Documents. Such interpretations and decisions of District shall be final and binding upon Contractor.

### **1.4 INTERPRETATION OF CONTRACT DOCUMENTS**

1.4.1 The Contract Documents are complementary and what is required by one shall be as binding as if required by all.

1.4.2 In general, the Drawings will show dimensions, positions, and kind of construction; and the Special Provisions and Technical Specifications will define materials, quality, and standards. Any Work called for on the Drawings and not mentioned in the Special Provisions and Technical Specifications, or vice versa, shall be performed as though fully set forth in both. Work not particularly detailed, marked or specified, shall be the same as similar parts that are detailed, marked, or specified.

1.4.3 Unless otherwise stated in the Contract Documents, technical words and abbreviations contained in the Contract Documents are used in accordance with commonly understood construction industry meanings and non-technical words and abbreviations are used in accordance with their commonly understood meanings.

1.4.4 The Contract Documents may omit modifying words such as "all" and "any," and articles such as "the" and "an." If a modifier or an article is not included in one statement and appears in another it is not intended to affect the interpretation of either statement. The use of the word "including," when following any general statement, shall not be construed to limit such statement to specific items or matters set forth immediately following such word or to similar items or matters whether or not non-limiting language (such as "without limitation," "but not limited to," or words of similar import) is used with reference

thereto, but rather shall be deemed to refer to all other items or matters that could reasonably fall within the broadest possible scope of such general statement. To the extent the Contract Documents define obligations of the parties, the word "shall" means a mandatory obligation and "may" means a permissive obligation.

1.4.5 Whenever the context so requires, the use of the singular number shall be deemed to include the plural and vice versa. Each gender shall be deemed to include the other gender, and each shall include corporation, partnership, trust, or other legal entity whenever the context so requires. The captions and headings of the various subdivisions of the Contract Documents are intended only as a matter of reference and convenience and in no way define, limit, or prescribe the scope or intent of the Contract Documents or any subdivision thereof.

1.4.6 Any cross-references indicated between various subparagraphs or Drawings and Documents are provided for the convenience of Contractor and shall not be deemed to be all-inclusive.

1.4.7 Unless specifically noted to the contrary, it is the intention of the Contract Documents that all Work, equipment, casework, mechanical, electrical, and similar devices of whatever nature, be completely installed, hooked-up, made operational and made functional for the purpose such are intended, and that all costs therefor be included in the Contract Sum.

1.4.8 Figured dimensions on scale Drawings and on full size Drawings shall govern over scale Drawings without figured dimensions. The Drawings shall not be scaled to determine dimensions, and (except in the case of diagrammatic Drawings) shall be calculated from figures shown on the Drawings. Obvious discrepancies between scale and figured dimensions, not marked "not to scale," must be brought to the Construction Manager's attention before proceeding with the Work affected by the discrepancy.

1.4.9 If there is a conflict between or among any of the Contract Documents, Contractor shall immediately bring such conflict to the attention of District, whose decisions regarding such conflict shall be final and binding as to the requirements of the Contract Documents. In the event of any conflicts between or among the Applicable Code Requirements, the more stringent shall govern. In resolving any conflict in the Contract Documents, the highest standard of quality and skill, the most stringent requirements, and the most specific provision of the Contract Documents shall govern and shall be required in the performance of the Work.

1.4.10 The general character of the Work is shown in the Contract Documents, but Changes, Modifications, clarifications and refinements may be made in details when needed to more fully explain the Work. Provided that there is a logical evolution of the Bid Documents that were bid by Contractor or were reasonably inferable as necessary to provide a completed and fully operational system,

facility or structure, the same shall be considered part of the scope of the Work to be performed without adjustment in the Contract Sum or the Contract Time.

1.4.11 Where on any Drawing a portion of the Work is drawn out and the remainder is indicated in outline, the drawn-out parts shall apply also to all other like portions of the Work. Where ornament or other detail is indicated on starting only, such detail shall be continued throughout the course of parts in which it occurs and shall also apply to all other similar parts in the Work unless otherwise indicated.

1.4.12 For convenience, the Special Provisions and Technical Specifications are arranged in various trade subparagraphs, but such segregation shall not be considered as limiting the Work of any subcontract or trade. Contractor shall be solely responsible for all subcontract arrangements of Work regardless of the location or provision in the Special Provisions and Technical Specifications.

1.4.13 Contractor will provide all necessary labor, equipment, transportation, and incidentals required to complete the Work, even if the Contract Documents do not describe the Work in complete detail.

1.4.14 Drawings and diagrams for mechanical, plumbing and electrical Work shall be considered as diagrammatic only, not to be used for any structural guidance or physical layout, unless specifically detailed or dimensioned, and Contractor shall be responsible to provide any and all numbers and lengths of mechanical, plumbing or electrical fittings, wire, conduit, connections, attachments or similar materials needed to complete the Work, at no adjustment to the Contract Sum or Contract Time, whether or not they exceed the numbers of such pieces or the lengths indicated by the Drawings.

---



## **ARTICLE 2 – DISTRICT**

### **2.1 INFORMATION AND SERVICES PROVIDED BY DISTRICT**

2.1.1 District will furnish up to five (5) (sets) of the Contract Documents or portions thereof free of charge.

2.1.2 Except as otherwise provided in the Special Provisions and Technical Specifications and Article 3.18 herein, District shall obtain and pay for any permits, easements and governmental approvals for the use or occupancy of permanent structures required in connection with the Work.

2.1.3 Requests for Information Responses, Approvals and decisions required of District, Design Consultant or Construction Manager under the Contract Documents shall be provided by District, Design Consultant or Construction Manager to Contractor upon request in a timely manner in order to avoid unreasonable Delay in the orderly and sequential progress of the Work. Notwithstanding the foregoing, failure by District, Design Consultant, Construction Manager or District's other consultants to provide Request for Information Response, Approvals or decisions shall not be considered as a basis for Contractor to seek adjustment in the Contract Time until seven (7) Days after Contractor has delivered written notice to District and to the person from whom such information, Approval or decision is needed, stating the following:

- (i) You are hereby notified that certain information, approval or decision described herein has not been provided in accordance with this provision and if not provided within seven (7) Days from this notice may result in additional cost or a request for time extension due to Delay;
- (ii) A detailed description of the information, approval or decision required; and
- (iii) The date by which the information, approval or decision must be received as to not result in Delay to the Project, which shall in no event be earlier than seven (7) Days after the date of District's receipt of such notice.

### **2.2 ACCESS TO PROJECT SITE**

2.2.1 District will make available, no later than the date designated in the current Construction Schedule accepted by District, the lands and facilities upon which the Work is to be performed, including such access and other lands and facilities designated in the Contract Documents, for use by Contractor.

### **2.3 DISTRICT'S RIGHT TO STOP THE WORK**

2.3.1 If Contractor fails to correct Defective Work as required by Article 12.2, fails to perform the Work in accordance with the Contract Documents, or violates

(v) General Conditions

any Applicable Code Requirement, District may direct Contractor to stop the Work, or any portion thereof, until the cause for such order has been eliminated by Contractor. Contractor shall not be entitled to any adjustment of Contract Time or Contract Sum as a result of any such order. District shall have no duty or responsibility to Contractor or any other party to exercise the right to stop the Work.

## **2.4 DISTRICT'S RIGHT TO CARRY OUT THE WORK**

2.4.1 If Contractor fails to carry out the Work in accordance with the Contract Documents, fails to provide sufficient labor, materials, equipment, tools and services to maintain the Construction Schedule, or otherwise fails to comply with any requirement of the Contract Documents, and fails within the time specified in the Contract Documents, after receipt of notice from District to promptly commence and thereafter diligently continue to completion the correction of such failure, District may, without prejudice to other remedies District may have, correct such failure at Contractor's expense. In such case, District shall be entitled to deduct from payments then or thereafter due Contractor the cost of correcting such failure, including compensation for the additional services and expenses of District and District's consultants made necessary thereby. If payments then or thereafter due Contractor are not sufficient to cover such amounts, Contractor shall pay the additional amount to District.

---

## **ARTICLE 3 – CONTRACTOR**

### **3.1 REVIEW OF THE SITE, CONTRACT DOCUMENTS AND FIELD CONDITIONS**

3.1.1 Contractor acknowledges that it is satisfied as to character, quality, and quantities of surface and subsurface materials or obstacles to be encountered insofar as reasonably ascertainable from a careful inspection of the Site (including, without limitation, Existing Improvements on the Site) and from the geological investigation reports, data and similar information made available to Contractor by District. Any failure by Contractor to take such information or conditions into consideration will not relieve Contractor from responsibility for estimating the difficulty and cost of successfully completing the Work within the Contract Sum and Contract Time.

3.1.2 Contractor warrants and represents that it has carefully reviewed and compared the Bid and Bid Documents prior to submitting its Bid and executing the Contract. Based upon its careful review, Contractor agrees that it shall not be entitled, and conclusively waives any right, to an adjustment in the Contract Sum or Contract Time for any additional or unforeseen costs or Delay in the performance of Work due to conditions in Contract Documents constituting errors, omissions, conflicts, ambiguities, lack of coordination or noncompliance with Applicable Code Requirements, if such conditions were either discovered by Contractor or could have been reasonably discovered by Contractor or its Subcontractors or Sub-subcontractors, of every Tier, in the exercise of care and diligence in the review of the Bid Documents.

3.1.3 If Contractor discovers what it perceives to be errors, omissions, conflicts, ambiguities, lack of coordination or noncompliance with Applicable Code Requirements in the Contract Documents, then Contractor shall, before proceeding with the Work affected, notify District or the Construction Manager in writing within two (2) Days stating both of the following:

- (i) A detailed description of the conditions discovered; and
- (ii) Contractor's request for clarification, further details, or correction of the Contract Documents.

Failure by Contractor to provide written notice within the period of time required shall result in Contractor waiving any right to adjustment in the Contract Sum or Contract Time on account thereof.

3.1.4 Contractor shall submit written notice thereof to District if, in Contractor's opinion, District, Design Consultant or Construction Manager furnishes additional written or verbal instructions, information or directions that Contractor considers constitute additional Work or Delay for which Contractor believes it is entitled to an adjustment of the Contract Sum or Contract Time. Such notice shall be provided

(v) General Conditions

prior to performance of the Work affected by such instruction, information, or direction and seven (7) Days after Contractor first received such instruction, information or direction. Failure to provide such written notice in the manner required by this provision shall constitute a waiver by Contractor of the right to any adjustment to the Contract Sum or Contract Time by reason of such instruction, information, or direction.

3.1.5 Field measurements shall be taken, and existing field conditions verified by Contractor, and carefully compared with the Contract Documents and other information known to Contractor before commencing the Work. Contractor shall promptly report in writing to the Construction Manager any errors, inconsistencies, or omissions discovered.

3.1.6 If Contractor or any Subcontractor or Sub-subcontractor, of every Tier, performs any portion of the Work which it knows, or in the exercise of care and diligence should have known, involves an error, omission, conflict, ambiguity, lack of coordination or noncompliance with Applicable Code Requirements, without notifying and obtaining the written Approval of District or before obtaining a written clarification, interpretation, instruction or decision from District, Design Consultant or Construction Manager, then any Work that is performed that is not in conformance with the clarifications, interpretation, instruction or decision of District, Design Consultant or Construction Manager shall be removed or replaced and Contractor shall be responsible for the resultant Losses with no adjustment in the Contract Sum or Contract Time.

3.1.7 District does not impliedly or expressly warrant, and assumes no responsibility for, the accuracy, suitability or completeness of the Bid Documents, Contract Documents or of the data, opinions or recommendations contained or expressed in any information, data or reports provided to Contractor relating to the following conditions at the Site: geological, soils, hydrologic, groundwater, Hazardous Substances, surface and subsurface obstructions, surface and subsurface utilities or Existing Improvements. Existing Improvements at the Site, for which no specific description is made on the Drawings, but which could be reasonably assumed to interfere with the satisfactory completion of the Work, shall be removed and disposed of by Contractor, but only upon the specific direction and control of District. Without limitation to the foregoing, and notwithstanding any information provided by District pertaining to groundwater elevations and/or geological and soils conditions encountered, it is understood that it is Contractor's responsibility to determine and allow for the elevation of groundwater, and the geological and soils conditions at the date of performance of the Work and any difference between elevation of groundwater and the geotechnical and soils conditions shown in the information provided by District and groundwater and the geotechnical and soils conditions actually encountered will not be considered as a Differing Site Condition or as a basis for an adjustment to the Contract Sum or Contract Time.

## **3.2 SUPERVISION AND CONSTRUCTION PROCEDURES**

3.2.1 Contractor shall supervise, coordinate, and direct the Work using Contractor's best skill and attention and shall provide supervision sufficient to assure proper coordination and timely completion. Contractor shall be solely responsible for and have control over construction means, methods, techniques, safety, sequences, procedures, and the coordination of all portions of the Work.

3.2.2 Contractor shall be responsible for the accurate layout of all portions of the Work and shall verify all dimensions on the Drawings and shall report to District any discrepancies before proceeding with related Work.

3.2.3 Contractor may be assigned working space adjacent to the Site, and all field offices, materials and equipment shall be kept within this area. Contractor shall be responsible for leaving the space in as good condition as Contractor found it or restoring it to the condition it was in prior to Contractor commencing the Work.

3.2.4 Contractor shall be responsible to District for acts and omissions of Contractor's agents, employees, and of Contractor's Subcontractors and Sub-subcontractors, of every Tier, and their respective agents and employees. Unless otherwise stated in the Contract Documents, references to Contractor, when used in reference to an obligation bearing upon performance of the Work, shall be deemed to include Contractor's Subcontractors and Sub-subcontractors of every Tier.

3.2.5 Contractor shall not be relieved of its obligation to perform the Work in accordance with the Contract Documents by the act(s) or omission(s) by District in the administration of the Contract, or by tests, inspections or Approvals required or performed by persons or firms other than Contractor.

## **3.3 RESPONSIBILITY FOR THE WORK**

3.3.1 Contractor shall be in charge of and responsible for all portions of the Work of the Contract and shall be responsible for conforming such portions to the requirements of the Contract Documents and readying such portions to receive subsequent Work.

3.3.2 Contractor shall at all times maintain good discipline and order among its employees and Subcontractors. Contractor shall provide competent, fully qualified personnel to perform the Work, and shall ensure that each Subcontractor and Sub-subcontractor engaged on the Site arranges the storage of materials and equipment and performance of its Work so as to interfere as little as possible with Separate Contractors or other persons engaged in work for District on the Site.

3.3.3 During the installation of Work, Contractor shall insure that existing

facilities, fences, and other structures are all adequately protected. Upon Final Completion of all Work, all facilities that may have been damaged shall be restored to a condition acceptable to District.

3.3.4 Contractor is responsible for the security of the Site and all Work provided under the terms of this Contract, as well as all Work provided by Separate Contractors that occurs on the Site at any time prior to Final Completion and Acceptance of the Work by District.

### **3.4 LABOR, WORKMANSHIP, MATERIALS AND MANUFACTURED ITEMS**

3.4.1 Contractor shall provide and pay for all labor, materials, equipment, tools, construction equipment and machinery, water, heat, utilities, transportation and other facilities and services necessary for proper execution and completion of the Work, whether temporary or permanent, and whether or not incorporated or to be incorporated in the Work. Unless otherwise provided in the Contract Documents or otherwise Approved by the Construction Manager, all articles, equipment, and materials incorporated in the Work shall be new, of good quality, undamaged and not defective.

### **3.5 CONTRACTOR'S WARRANTY**

3.5.1 Contractor warrants to District that all materials and equipment used in or incorporated into the Work will be of good quality, new and free of liens, Claims and security interests of third parties; that all labor, installation, materials, and equipment used or incorporated into the Work will be of good quality and free from defects; and that the Work will conform with the requirements of the Contract Documents and Applicable Code Requirements. If required by District, Contractor shall furnish satisfactory evidence as to the kind and quality of materials and equipment. Manufactured items installed in the Work and not specifically covered in the Contract Documents are to be installed in strict accordance with manufacturers' current printed instructions.

3.5.2 All materials to be incorporated in the Work shall be protected from damage during delivery, storage, and handling, and after installation until Acceptance of the Work, and Contractor shall, without charge to District, be responsible for all damage due to Contractor's failure to provide such proper protection.

### **3.6 CONSTRUCTION METHODS AND PROCEDURES**

3.6.1 The methods and procedures adopted by Contractor shall be such as to secure a quality of Work satisfactory to District and to enable completion of the Work in the time agreed upon. If at any time such methods and procedures appear inadequate, District may order Contractor to improve their character or increase efficiency, and Contractor shall conform to such order; but the failure of District to order such improvement of methods or increase of efficiency will not

relieve Contractor from its obligation to perform the Work in accordance with the Contract Documents or within the Contract Time.

3.6.2 If the Contract Documents give specific instructions concerning construction means, methods, techniques, sequences or procedures, Contractor shall be fully and solely responsible for the Site safety for implementing such means, methods, techniques, sequences, or procedures. If Contractor determines that such means, methods, techniques, sequences, or procedures may not be safe, Contractor shall give written notice to District and shall not proceed with that portion of the Work without further written instruction by District.

### **3.7 TAXES**

3.7.1 Contractor, Subcontractors and Sub-subcontractors are responsible for paying all sales, consumer, business license, use, income and payroll, and similar taxes for the Work or portions thereof provided by Contractor and Subcontractors.

### **3.8 LEGAL REQUIREMENTS**

3.8.1 Contractor shall perform the Work in accordance with all Applicable Code Requirements, even though such requirements are not specifically mentioned in the Contract Documents.

3.8.2 When the Work required by the Contract Documents is in conflict with any Applicable Code Requirement, Contractor shall notify District and shall not proceed with the Work until District has so ordered.

### **3.9 SUPERINTENDENT/PROJECT STAFF**

3.9.1 Contractor shall employ a complete and competent project staff for the duration of the Work, which shall include separate individuals designated to act as Superintendent(s), project manager(s), project engineer(s) and administrative assistant(s), plus such other members as necessary to diligently prosecute the Work. Contractor shall not replace the designated Superintendent or project manager without a minimum seven (7) Day written notice and only with the written approval of District, which may be granted or withheld in its sole discretion. Any Project staff member and any replacement member shall be subject to the approval of District, which may be granted or withheld in its sole discretion. Upon notice from District requesting replacement of any Project staff member who is unsatisfactory to District, Contractor shall in a timely manner, but in no event longer than three (3) Days after notification, replace such member with a competent member satisfactory to District. Failure by Contractor to comply with this provision shall entitle District, at its option exercised in its sole discretion, to terminate the Contract or suspend the Work until compliance is demonstrated. All costs or damages associated with such termination or suspension shall be

borne by Contractor, without adjustment in the Contract Sum or Contract Time.

3.9.2 The Superintendent shall be at the Site at all times during the performance of the Work. The Superintendent shall represent Contractor and communications given to and acknowledged by the Superintendent shall be binding on Contractor. Further, communications issued by or received from the Superintendent shall be deemed as binding on Contractor. The Superintendent must be able to read, write and communicate fluently in English. The Superintendent shall not perform the Work of any trade, pickup materials or perform any Work not directly related to the supervision and coordination of the Work.

### **3.10 SCHEDULES REQUIRED OF CONTRACTOR**

3.10.1 Contractor shall submit a preliminary Construction Schedule to District in a form approved by the Construction Manager at the Pre-Construction Meeting.

3.10.2 Updated Construction Schedules shall be submitted in the form and frequency approved by the Construction Manager.

3.10.3 The Construction Schedule and Construction Schedule updates shall meet the following requirements:

.1 Schedules must be suitable in format and clarity for monitoring progress of the Work and shall utilize the critical path method of scheduling.

.2 Schedules must provide necessary data about the timing for District's decisions and District-furnished items.

.3 Schedules must be in sufficient detail to demonstrate adequate planning and staffing for the Work.

.4 Schedules must represent a practical plan to complete the Work within the Contract Time. If at any time during the Work, any activity is not completed by its latest scheduled completion date, Contractor shall notify the Construction Manager within seven (7) Days of Contractor's plans to reorganize the work force to return to the schedule and prevent Delays on any other activity.

.5 An updated Construction Schedule shall be submitted with each progress payment request, but no less frequently than monthly, and shall include all of the following:

(i) A written narrative report detailing the actual progress of the Work as of the date of submission;

(ii) The expected progress of the Work as of such date according to the

(v) General Conditions



approved Construction Schedule;

(iii) The reasons for any variance between the approved Construction Schedule and the updated Construction Schedule; and

(iv) Contractor's plan for placing the Work back on Schedule, at Contractor's expense.

3.10.4 Contractor shall plan, develop, supervise, control, and coordinate the performance of the Work so the progress, sequence and timing of the Work conform to the current accepted Construction Schedule. Contractor shall continuously obtain from Subcontractors information and data about the planning for and progress of the Work, the ordering and fabrication of materials, required Submittals, and the delivery of equipment, shall coordinate and integrate such information and data in updated Construction Schedules and Record Documents, and shall monitor the progress of the Work and the delivery of equipment. Contractor shall act as the expeditor of potential and actual delays, interruptions, hindrances or disruptions for its own forces and those forces of Subcontractors, regardless of Tier. Contractor shall cooperate with District in the development of the Construction Schedule and updated Construction Schedules.

3.10.5 District's review, comments, requests for revisions, or acceptance of any schedule or scheduling data shall not:

(i) Relieve Contractor from its sole responsibility for the feasibility of the schedule and to plan for, perform, and complete the Work within the Contract Time;

(ii) Transfer responsibility for any schedule from Contractor to District; nor

(iii) Imply District's agreement with any assumption upon which such schedule is based or any matter underlying or contained in such schedule.

3.10.6 Failure of District to discover errors or omissions in schedules that it has reviewed, or to inform Contractor that Contractor, Subcontractors, or others are behind schedule, or to direct or enforce procedures for complying with the Construction Schedule, shall not relieve Contractor from its sole responsibility to perform and complete the Work within the Contract Time and shall not be a cause for an adjustment of the Contract Time or the Contract Sum.

3.10.7 Contractor shall cooperate with and coordinate its schedule with work of District and District's Separate Contractors.

(v) General Conditions

### 3.11 DOCUMENTS AND SAMPLES AT PROJECT SITE

3.11.1 Contractor shall maintain one (1) set of As-Built Documents at the Site, which shall be kept up to date on a daily basis at all times during the performance of the Work. All performed changes, deletions, or additions in the Work from that shown in the Contract Documents shall be recorded accurately and completely in the Record Documents. Upon Final Completion and as a condition to final payment, each sheet of the As-Built Documents and other Record Documents shall be signed and attested to by a representative of Contractor as being complete and accurate.

3.11.2 Contractor shall, at all times during performance of the Work, also maintain the following at the Site:

- (i) The latest updated Construction Schedule approved by District;
- (ii) Shop Drawings, product data, and samples; and
- (iii) All other required Submittals.

At all times during the Project, these documents shall be available to District, the Construction Manager and the Design Consultant to audit, excerpt, or copy as they see fit. Upon Final Completion or termination of the Construction Contract, these shall be delivered to District.

3.11.3 It shall be the responsibility of Contractor to maintain a current and complete record of all Changes performed during the progress of the Project construction. The record shall be in the form of a complete set of prints of the As-Built Documents on which daily recordings are made by Contractor, indicating in detail and dimension each variation from the original set of Contract Documents and including all the construction Work. At the completion of construction, Contractor shall, as a requirement of the Final Completion of the Work, certify that to the best of its knowledge, the As-Built Documents are true and accurate, and that the indications thereon represent all Changes performed during the construction of the Project. At the Final Completion of the Work, the As-Built and other Record Documents shall become the property of District.

3.11.4 Contractor, in concert with the Design Consultant and the Construction Manager, shall review Contractor's As-Built Documents for conformance with all current Changes prior to presenting its monthly Application For Payment. The monthly progress payment statement will not be accepted or processed by District unless the As-Built Documents are current and complete, and Approved by District.

3.11.5 At the Final Completion of the Work, all information annotated monthly on the As-Built Documents shall be fully incorporated by Contractor onto a set of mylar reproducibles furnished by Contractor. These As-Built Documents will

become the permanent property of District at the Final Completion of the Work. If the As-Built Documents are prepared on a computer, then the revised computer files shall also be provided to District in the file format specified by District.

### **3.12 SUBMITTALS**

3.12.1 Submittals are not Contract Documents. Their purpose is to demonstrate, for those portions of the Work for which Submittals are required, how Contractor proposes to conform to the information given and the design concept expressed in the Contract Documents. Prior to starting Work, Contractor shall provide to District an initial schedule for all materials and equipment for which shop drawings are required by the Contract Documents. For each required shop drawing, Contractor shall provide to District the date for the drawing's intended Submittal to the Design Consultant for review. The date required for its return to avoid Delay in any activity beyond the scheduled start date shall also be given.

3.12.2 All shop drawings and other Submittals shall be provided at Contractor's expense, when required by the Contract Documents or requested by the Construction Manager.

3.12.3 Contractor shall review, stamp approved, and submit to the Construction Manager, all Submittals required by the Contract Documents to be submitted and reviewed by the Design Consultant. Submittals to the Construction Manager without evidence thereon of Contractor's approval shall be returned, without further consideration, for resubmission in accordance with these requirements. Submittals shall be provided within the time frame specified in the Special Provisions and Technical Specifications in accordance with the Construction Schedule, and in such sequence as to cause no Delay in the Work or in the activities of District or of Separate Contractors. Submittals made by Contractor which are not required by the Contract Documents, may be returned without action by the Construction Manager or Design Consultant. Submittal to the Construction Manager and Design Consultant must include a statement, in writing, identifying any deviations from the Contract Documents required due to manufacturing or installation limitations contained in the Submittal.

3.12.4 All Submittals shall be submitted in six (6) sets, accompanied by letters of transmittal, and addressed to the Construction Manager for review. Unless otherwise specified in the Contract Documents, Submittals consisting of Drawings or Plans shall be in the form of six (6) copies. The Submittal must be in accordance with the Contract Documents. If the Submittal involves a request for substitution of materials, the request shall be clearly identified on the Submittal that it is a "Request for Substitution." Unless so clearly marked, Submittals shall not be considered as a request for substitution. If changes or corrections are required, three marked-up prints shall be returned to Contractor. Submittals shall consist of the appropriate combination of catalog sheets, material lists, manufacturer's brochures, technical bulletins, specifications, diagrams, or product samples, necessary to describe a system, product, or item. The

letter of transmittal shall give a list of the numbers of the sheets submitted. All sheets shall be marked with the name of the Project and the name of Contractor, shall be numbered consecutively, and shall be referenced to the sheets or paragraphs of the Contract Documents, referenced by sheet or subparagraph affected. Submittals shall be combined for singular assemblies, items or materials.

3.12.5 No Work requiring a Submittal shall be performed by Contractor until the Submittal has been reviewed by District, Construction Manager or Design Consultant and the Design Consultant has documented the exceptions noted on the Submittal. Contractor shall allow twenty (20) Days for review of Submittals. Once the Submittal is returned to Contractor by the Construction Manager with a statement that it has been reviewed and no exceptions are taken or further action requested, such Work shall be performed in accordance with the Submittal and the Contract Documents.

3.12.6 Contractor's Submittals represent that Contractor has determined or verified materials and field measurements and conditions related thereto and that it has checked and coordinated the information contained within such Submittals with the requirements of the Contract Documents and Submittals for related Work.

3.12.7 If Contractor discovers any conflicts, omissions or errors in Submittals, Contractor shall notify the Construction Manager and receive instruction before proceeding with the affected Work.

3.12.8 Contractor shall remain solely responsible, notwithstanding District, Construction Manager or Design Consultant's review or approval of Submittals, for deviations (including, without limitation, those arising from standard shop practice) from requirements of the Contract Documents, unless Contractor has specifically informed District, Construction Manager or Design Consultant in writing of such deviation at the time of transmitting the Submittal and District, Construction Manager or Design Consultant has given written approval of such deviation. No adjustment in the Contract Sum or Contract Time shall be permitted with respect to any such deviations that are noted in writing by Contractor and as to which District, Construction Manager or Design Consultant takes no exception or approves.

3.12.9 After review of Contractor's Submittals by District, Construction Manager or Design Consultant, the Construction Manager will transmit to Contractor the required number of sets. If the Submittals are found to be incomplete or incorrect, Contractor shall resubmit after corrective action has been taken. Contractor shall reimburse District, or District may withhold from payments due Contractor, sums owing by District for any fees charged by District, Construction Manager or Design Consultant or District's other consultants for more than two (2) reviews of a Submittal, or for accelerated review in a shorter time than set forth in the approved Construction Schedule, if requested by Contractor or caused by late Submittals by Contractor. The return of a Submittal due to failure to comply with the

Contract Documents or for correction or additional information shall be considered a review.

3.12.10 Review of Submittals by District, Construction Manager or Design Consultant will be general and for conformance with design intent and shall not relieve Contractor from the responsibility for proper fitting and construction of the Work, nor from furnished materials and Work required by the Contract which may not be indicated on the reviewed Submittals.

3.12.11 Submittals shall be in English, be of good quality, and be of a size and scale to clearly show all necessary details. Submittals shall show in detail the size, sections, and dimensions of all members; the arrangement and construction of all connections, joints and other pertinent details; and all holes, straps and other fittings required by other Separate Contractors for attaching their Work. When required by District, Construction Manager or Design Consultant, engineering computations shall be submitted. Contractor shall be responsible for delivering duplicates of Submittals to all other persons whose Work is dependent thereon.

3.12.12 Contractor shall, at all times, maintain at the Site a complete file of all District, Construction Manager or Design Consultant-reviewed Submittals.

### **3.13 TRADE NAMES, SUBSTITUTIONS**

3.13.1 Except as otherwise noted and permitted by law, whenever in the Contract Documents any material or process is indicated or specified by two or fewer patents, proprietary names, brand names and/or manufacturers, such specification shall be deemed pursuant to Public Contract Code 3400 to be followed by the words "or approved equal".

3.13.2 Contractor shall have ten (10) Days after submission of the Bid to submit data substantiating substitution of "or equal" items. District, with the advice of the Design Consultant, will determine whether the proposed brand or item is equal in quality and utility to that specified in the Contract Documents, and its decision shall be final. District, Construction Manager or Design Consultant may require the submission of samples, formulae, and/or statements of physical properties for consideration in determining equality of the material or process in question. No proposal for an equal will be considered complete unless accompanied by complete information and descriptive data necessary to determine the equality of the offered equal.

3.13.3 If Contractor requests use of substitute material or process, it shall be incumbent upon Contractor to furnish sufficient evidence to support the claim of equality to the satisfaction of District, Construction Manager or Design Consultant.

3.13.4 If District accepts for use in the Project a substitute material or process

(v) General Conditions

which in the opinion of District, Construction Manager or Design Consultant is not the equal of that specified, a Change Order shall be issued issuing a credit to District for the difference in value.

3.13.5 Substitutions by Contractor that are incorporated into the Work without the prior review and Approval by District, Construction Manager or Design Consultant in accordance with the requirements of the Contract Documents shall be deemed to be Defective Work.

3.13.6 The specified Construction Contract completion time shall not be affected by any circumstance developing from the substitution provisions of this Article 3.13.

### **3.14 DAILY REPORTS BY CONTRACTOR**

3.14.1 At the end of each working day, Contractor shall submit a daily report to the Construction Manager (on a form provided by or accepted by the Construction Manager) listing:

- (i) At the end of each working day, Contractor shall submit a daily report to the Construction Manager (on a form provided by or accepted by the Construction Manager) listing: Labor - Names of workers, classification, and hours worked;
- (ii) Material - Description and list of quantities of materials used;
- (iii) Equipment - Type of equipment, size, identification number, and hours of operation, including loading and transportation, if applicable;
- (iv) Inspection and Testing Activities - Name, District or company and items involved;
- (v) Areas of Work - The areas of the Site on which Work was performed and a detailed description of the stage, status and progress of the Work in each such area at the beginning and end of the day;
- (vi) Accidents, Delays, Defective Work - Description in detail of any injuries to workers, accidents, Delays, or Defective Work that were encountered; and
- (vii) Other Services and Expenditures - Description in such detail as District may require of other services and expenditures.

3.14.2 Reports by Subcontractors and Sub-subcontractors that comply with the requirements of this Article 3.14 shall also be submitted to the Construction Manager through Contractor at the end of each working day.

3.14.3 Submission of daily reports by Contractor, Subcontractors and Sub-subcontractors, of every Tier performing Work on the Site shall be a condition

precedent to Contractor's right to payment under the Contract.

3.14.4 Facts, notice, or information contained in daily reports of Contractor or its Subcontractors or Sub-subcontractors, whether known or not known to District or Construction Manager, shall under no circumstances be considered evidence of compliance by Contractor with any of the specific written notice requirements of the Contract Documents.

### **3.15 CUTTING AND PATCHING**

3.15.1 Contractor shall do all cutting, fitting, or patching of the Work required to make all parts of the Work join properly and to allow the Work to join the work of Separate Contractors shown in, or reasonably implied by, the Contract Documents.

3.15.2 Contractor shall not endanger the Work, the Project, Existing Improvements, or adjacent property by cutting, digging, or otherwise. Contractor shall not cut or alter the work of any Separate Contractor without the prior consent of District.

3.15.3 In all cases, cutting shall be performed under the supervision of competent workers skilled in the applicable trade and shall cause the openings to be cut as small as possible to minimize unnecessary damage.

### **3.16 ACCESS TO THE WORK**

3.16.1 District, Construction Manager, Design Consultant, their consultants, and other persons authorized by District shall at all times have access to the Work wherever it is in preparation or progress. Contractor shall provide safe and proper facilities for such access and for inspection.

3.16.2 District may, at any time, and from time to time during the performance of the Work, enter the Project for the purpose of installing any necessary other work by District labor or other contracts or for any other purpose. Contractor shall cooperate with District and not interfere with other work being done by or on behalf of District.

### **3.17 ROYALTIES AND PATENTS**

3.17.1 Contractor shall pay all royalties and license fees required for the performance of the Work. Contractor shall immediately notify District if it learns of any circumstances that may constitute an infringement of patent rights and shall defend and indemnify District and the members of the Project Team in accordance with Article 3.21 against Losses, liabilities, suits, or Claims resulting from Contractor's or any Subcontractor's or Sub-subcontractor's infringement of patent rights.

### **3.18 PERMITS AND LICENSES**

3.18.1 Contractor and all Subcontractors shall obtain and be responsible for the cost of all permits and applications related to the construction of the Project.

### **3.19 DIFFERING SITE CONDITIONS**

3.19.1 Save and except as permitted for Differing Site Conditions as defined in this Article 3.19, Contractor agrees to solely bear the risk and the additional cost and Delay of all concealed or unknown conditions at the Site or in Existing Improvements, without adjustment to the Contract Sum or Contract Time.

3.19.2 Differing Site Conditions are those conditions encountered at the Site or in Existing Improvements that are (1) subsurface or concealed conditions which differ materially from those indicated in the Contract Documents; or (2) unknown physical conditions at the Site, of an unusual nature, differing materially from those ordinarily encountered and generally recognized as inherent in the Work of the character provided for in the Contract Documents.

3.19.3 If Contractor encounters conditions it believes constitute Differing Site Conditions, then notice of such conditions shall be immediately reported to District and the Construction Manager followed within twenty-four (24) hours by a written notice stating a detailed description of the conditions encountered.

3.19.4 District shall promptly investigate Contractor's report of Differing Site Conditions. If District finds that Differing Site Conditions exist, in accordance with this Article 3.19, an adjustment shall be made in the Contract Sum and Contract Time in such amount as District approves.

3.19.5 If Contractor intends to seek an adjustment to the Contract Sum or Contract Time based upon Differing Site Conditions, it must, within seven (7) Days after it first discovered, or should have discovered in the exercise of diligence and care, the existence of such Differing Site Conditions, submit a written statement setting forth a detailed cost breakdown in the form required by Article 7.2 setting forth the basis of Contractor's calculation of the costs saved or incurred, detailed information demonstrating the effect on the Construction Schedule in the same manner as required by the Contract Documents for obtaining approval of extensions of time, identification of the Bid Documents that formed the basis of Contractor's Bid estimate to perform the Work affected by such conditions and a complete and detailed explanation of the factual basis for the request.

3.19.6 Failure by Contractor to strictly comply with the requirements of this Article 3.19 concerning the timing and content of any notice of Differing Site Conditions or request for adjustment in Contract Sum or Contract Time based on Differing Site Conditions shall be deemed a waiver of any right by Contractor for an adjustment in the Contract Sum or Contract Time by reason of such conditions.



3.19.7 No Claim by Contractor for additional compensation for Differing Site Conditions shall be allowed if asserted after final payment under the Construction Contract.

## **3.20 INSPECTIONS**

3.20.1 In order to allow for inspection by District and other agencies, or any inspection required elsewhere in the Special Provisions and Technical Specifications, Contractor shall notify District in writing three (3) Days in advance of the permanent concealment of any materials or Work.

3.20.2 Whenever Contractor desires to carry on the Work of this Construction Contract at hours other than 7:00 AM to 6:00 PM, Monday through Friday and from 9:00 AM to 5:00 PM on Saturdays, it shall request authorization in writing from District for such Work at least twelve (12) Days in advance and, if approved to proceed, Contractor agrees to pay overtime reimbursement of costs, of such required inspector(s) and the Construction Manager, Design Consultant and/or other District consultants whose presence is necessary and requested by District.

3.20.3 If any Work is concealed or performed without the prior notice specified above, then the Work shall be subject to such tests or exposure as may be necessary to prove to District that the materials used, and the Work done are in conformity with the Contract Documents. All labor and equipment necessary for exposing and testing shall be furnished by Contractor at its expense. Contractor shall replace, at its own expense and without reimbursement by District, any materials or Work damaged by exposure and any faulty materials or work evidenced by such exposure or testing.

3.20.4 When, in order to comply with the intent of the Contract Documents, inspection must be made at the plant or mill of the manufacturer or fabricator of material or equipment, Contractor shall notify District a sufficient length of time in advance to allow for arrangements to be made for such inspection.

3.20.5 Any inspection or approval by any representative or agent of District will not relieve Contractor of the responsibility of incorporating into the Work only those materials which conform to the Contract Documents, and any nonconforming materials all be removed from the Site whenever identified.

3.20.6 When Contractor believes it has achieved either Substantial or Final Completion of the Work, Contractor shall notify District and the Construction Manager in writing and request a Substantial or Final Completion inspection of the Work. District, Design Consultant and Construction Manager will make such inspection as soon thereafter as possible.

### **3.21 INDEMNIFICATION, STOP NOTICES**

3.21.1 Contractor shall fully comply with the Indemnification provision of the Construction Contract.

3.21.2 Contractor shall take steps to assure that a right of indemnification is included in all subcontracts, purchase orders and other contracts entered into by Subcontractors and Sub-subcontractors, of every Tier, for the Project that afford the same coverage, benefits and protections as provided for in Article 3.21.1.

3.21.3 Nothing set forth in the Contract Documents shall be construed to give rise to any express or implied right in favor of Contractor for indemnity or contribution.

3.21.4 Contractor shall not permit any stop notices or other claims, valid or invalid, to be served, filed, recorded, or otherwise imposed on District or on any part of the Work or the property on which the Work is performed. If any stop notice or other claim is served, filed or recorded in connection with the Work, District shall have the option, in its sole discretion, to require that Contractor immediately and at its own expense obtain a bond executed by a good and sufficient surety, in accordance with the California Civil Code, Section 3196, in a sum equal to one hundred twenty-five percent (125%) of the amount of such stop notice or claim. Such bond shall guarantee the payment of any amounts which the claimant may recover on the stop notice or claim, together with the claimant's costs of suit in any action to enforce such stop notice or claim if the claimant recovers therein. This remedy shall be in addition to all other rights and remedies of District under the Contract Documents and applicable law, including, without limitation, the right to withhold funds from sums due to Contractor.

### **3.22 PARKING**

3.22.1 Contractor shall provide and maintain suitable parking areas, for use by all construction workers and others performing work or furnishing services in connection with the Project, as required to avoid any need for parking personal vehicles where they may interfere with public traffic, construction activities or public parking.

### **3.23 USE OF THE PROJECT SITE AND CLEAN UP**

3.23.1 Contractor shall confine operations at the Site to areas permitted by Applicable Code Requirements and the Contract Documents. Contractor shall not encumber the Site with materials or equipment so that Separate Contractors' work is hindered or impeded due to such encumbrances.

3.23.2 Contractor shall, during performance of the Work, keep the Site and surrounding area free from the accumulation of excess dirt, dust, waste materials, water and rubbish caused by Contractor or any Subcontractors. Contractor shall continuously remove all excess dirt, waste material, water and rubbish caused

by Contractor and all tools, equipment, machinery and surplus materials from the Site and surrounding area at the completion of the Work. Adequate cleanup will be a condition for progress payments.

3.23.3 Personnel of Contractor, Subcontractors, and Sub-subcontractors shall not occupy, live upon, or otherwise make use of the Site during any time that Work is not being performed at the Site, except as otherwise provided in the Contract Documents.

3.23.4 Upon Final Completion of the Work, Contractor shall remove all construction facilities, appurtenances, tools, material, and other articles from the Site. The entire area, including all fixed equipment, floors, surfaces, and hardware shall be cleaned and restored to their original condition in accordance with the Special Provisions and Technical Specifications.

3.23.5 In addition to water sprinkling, temporary enclosures and anti-dust sweeping compounds should be used to limit dust and dirt rising and to keep the Site clean.

3.23.6 Construction materials shall be neatly stacked by Contractor when not in use. Dusty materials in piles or in transit shall be covered to prevent suspension of the dirt in the air. Contractor shall promptly remove splattered concrete, asphalt, oil, paint, corrosive liquids, and cleaning solutions from the affected surfaces to prevent marring or other damage.

3.23.7 Volatile wastes shall be properly stored in covered metal containers and removed daily. All other trash receptacles shall be promptly emptied when full. Contractor shall promptly and legally transport and dispose of removed and demolished items and waste materials not identified to be recycled or reused in a manner complying with local ordinances and anti-pollution laws. No rubbish or waste materials shall be burned, buried, or otherwise disposed of on the Site.

3.23.8 Sanitary facilities shall be of reasonable capacity, properly maintained throughout the construction period, and obscured from public view to the greatest practical extent. Contractor shall enforce the use of such sanitary facilities by all personnel at the Site. Sanitary facilities shall be on a portable trailer and shall be removed from the Site at the end of each workday. For sewer lining projects, Contractor shall provide additional sanitary facilities on a portable trailer to be used by the residents during lining installation (one sanitary facility per each 30 meters [100 feet]). Contractor shall remove those sanitary facilities as soon as relief holes are cut and notices of completion are delivered.

## **3.24 ENVIRONMENTAL CONTROLS**

3.24.1 AIR POLLUTION CONTROL. Contractor shall comply with all air pollution control rules, regulations, ordinances, and statutes which apply to any work performed pursuant to the Contract, including any air pollution control rules,

(v) General Conditions

regulations, ordinances, and statutes, specified in the California Government Code, Section 11017, or any other applicable law. In the absence of any applicable air pollution control rules, regulations, ordinances, or statutes governing solvents, all solvents, including but not limited to the solvent portions of paints, thinners, curing compounds and liquid asphalt used on the Project shall comply with the applicable material requirements of the San Luis Obispo County Air Pollution Control District. All containers of paint, thinner, curing compound or liquid asphalt shall be labeled to indicate that the contents fully comply with said requirements. Material to be disposed of shall not be burned.

.1 Mold. If any material susceptible to microbial growth becomes wet during the construction phase, that material should be carefully removed from the construction Site to prevent further contamination of the indoor air.

.2 VOC's. Construction materials that emit low levels of volatile organic compounds (VOC) shall be used to improve indoor air quality. Adequate ventilation of packaged dry products shall be used prior to installation. Contractor is responsible to ventilate the building during the application of wet products (e.g., paints, glues, sealants), which release their highest levels of VOC's during the curing period immediately after the application. Also, wet products shall be applied before installing materials that act as "sinks" such as carpets, fabric, ceiling tiles, movable partitions, furniture, etc. in order to reduce the chance of the "sinks" absorbing contaminants and slowly releasing them into the building over time.

.3 Off-Gassing. Contractor is responsible for identifying specific materials that require more complex ventilation to accelerate off-gassing. In addition to paints, glues and sealants, those materials that generally require temporary ventilation include, without limitation: composite wood products, plastics, waterproofing, insulation, fireproofing, caulking, acoustical ceilings, resilient flooring, and wood preservatives.

.4 Barriers. Barriers shall be used to prevent the migration of airborne pollutants from areas under construction and to mitigate any construction noise that may disrupt occupant activities. If effective controls for pollution emissions cannot be practically implemented, activities involving significant airborne pollutants shall be scheduled during off-hours at Contractor's expense. The Site shall be ventilated with fresh outside air during and immediately after the noxious activity.

.5 Exhaust. Contractor shall install a temporary exhaust in a construction area to prevent contaminated air from entering the building's return-air system, including, without limitation:

- (i) Removing windows in a space.

- (ii) Using available or dedicated exhaust systems (e.g., kitchen or toilet exhaust) that are not tied into the building's overall return-air system.

The building shall be flushed with full outdoor air for seven (7) Days prior to occupancy. Full capacity of the HVAC system shall be used for at least 2.5 ACH (air changes per hour), provided by temporary fans. During this time, the interiors shall be thoroughly cleaned, the HVAC ducts vacuumed, and air and HVAC system filters replaced.

3.24.2 TEMPORARY WATER, LIGHT AND POWER. Water for any purpose shall be obtained by Contractor, at its expense, from District. Contractor is to contact the Construction Manager for a phone number and contact person. In no case may Contractor obtain water from unmetered fire hydrants. The costs of obtaining water shall be included in the prices paid for the various contract items of work included and no additional compensation will be allowed therefore, unless otherwise specified in these Contract Documents. Contractor should be aware that there is a penalty for taking water from an unmetered fire hydrant. This amount shall be deducted from the payment due Contractor.

### 3.24.3 WATER POLLUTION CONTROL.

.1 Contractor shall use "Best Available Technology" and "Best Management Practices" to prevent the pollution of drains and watercourses by discharges of materials other than uncontaminated storm water. Prohibited discharge include storm water, discharge that may threaten to cause pollution, contamination or nuisance, sanitary waste, sediment and debris from erosion and other substances resulting from construction activities. Sanitary wastes will not be permitted to enter any drain or watercourse other than sanitary sewers. No sediment, debris or other substance will be permitted to enter sanitary sewers.

.2 Contractor to provide effective and continuous control of water pollution, including where Work is in small or multiple units, on an out of phase schedule or with modified construction procedures. Contractor shall determine which methods are most effective in achieving control of water pollution as a result of Contractor's operations. Contractor shall coordinate water pollution control work with all other Work performed by Contractor and Separate Contractors.

.3 Before starting any Work on the Project, Contractor shall submit to the Construction Manager for acceptance a program for effective control of water pollution. Such program shall show the schedule and detailed description for the pollution and erosion control work or practices included in the Construction Contract and for all water pollution control measures which Contractor proposes to take in connection with construction of the Project to minimize the effects of their operations upon adjacent streams and other bodies of water. Contractor shall not perform any clearing and grubbing or earthwork on the Project, other than that specifically authorized in writing by the Construction Manager, until such program has been approved by District or Construction Manager.

Contractor shall revise and bring up to date said water pollution control program at any time the Construction Manager makes written request for such revisions.

.4 The Construction Manager will notify Contractor within seven (7) Days of its learning of the acceptance or rejection of any submitted or revised water pollution control program.

.5 District shall not be liable to Contractor for failure to accept all or any portion of any originally submitted or revised water pollution control program, or for any Delays to the Work due to Contractor's failure to submit an acceptable water pollution control program. Contractor assumes sole responsibility for all costs associated with treatment of water polluted as a result of Contractor's Site activities, whether treatment is initiated by Contractor or District.

.6 Contractor may request the Construction Manager to waive the requirement for submission of a written program for control of water pollution when the nature of Contractor's operation is such that pollution discharge or erosion is not likely to occur. Waiver of this requirement will not relieve Contractor from responsibility for compliance with the other provisions of this Section. Waiver of the requirement for a written program for control of water pollution will not preclude District requiring submittal of a written program at a later time if the Construction Manager deems it necessary because of the effect of Contractor's operations.

.7 Where erosion damage which will cause water pollution is probable due to the nature of the material or the season of the year, Contractor's operation shall be so scheduled that permanent erosion control features will be installed concurrently with or immediately following grading operations.

.8 All water pollution control work required elsewhere in the Contract Documents which may be accomplished under the various contract items of Work will be measured and paid for as provided in said items of Work elsewhere in these Contract Documents.

.9 All water pollution control work performed in accordance with the accepted program which is not otherwise required under the Construction Contract and which is ordered by the Construction Manager will be paid for as Extra Work as provided for in the General Conditions. Except as otherwise provided in Article 3.24.3 or elsewhere in the Contract Documents, full compensation for conforming to the requirements of Article 3.24.3 shall be considered as included in the prices paid for the various contract items of Work and no additional compensation will be allowed therefore.

3.24.4 URBAN RUNOFF. The following Best Management Practices which address the problem of urban runoff shall apply to all projects undergoing construction in District. The Best Management Practices list set forth below is

required by District, and shall apply at the time of demolition of an existing structure or commencement of construction until receipt of a certificate of occupancy or certificate of completion:

.1 Runoff, sediments and construction waste from construction sites and parking areas shall not leave the site.

.2 Any sediments or other materials which are tracked off the Site shall be removed the same day. When determined necessary by the Construction Manager to provide temporary pollution control measures, a temporary sediment barrier shall be installed.

.3 On an emergency basis only, plastic covering may be utilized to prevent erosion of an otherwise unprotected area, along with runoff devices to intercept and safely convey the runoff. Excavated soil shall be located on the Site in a manner that eliminates the possibility of sediment running into the street or adjoining properties. Undocumented fills shall be covered until the soil is either used or removed.

.4 No washing of construction or other industrial vehicles shall be allowed adjacent to the Site. No runoff from washing vehicles on the Site is allowed to leave the Site.

.5 Drainage controls shall be utilized as needed, depending on the extent of proposed grading and topography of the Site, including, but not limited to the following: (i) detention ponds, sediment ponds or infiltration pits; (ii) dikes, filter berms or ditches; and (iii) down drains, chutes, or flumes.

3.24.5 STORMWATER POLLUTION. To avoid stormwater pollution, Contractor shall plan roadwork and pavement construction as follows:

(i) Apply concrete, asphalt, and seal coat during dry weather to prevent contaminants from contacting stormwater runoff.

(ii) Cover storm drain inlets and personnel access holes when paving or applying seal coat, slurry seal, fog seal, etc.

(iii) Always park paving machines over drip pans or absorbent materials, since they tend to drip continuously.

(iv) When making saw-cuts in pavement, use as little water as possible. Cover each catch basin completely with filter fabric during the sawing operation and contain the slurry by placing straw bales, sandbags, or gravel dams around the catch basin. After the liquid drains or evaporates, shovel or vacuum the slurry residue from the pavement or gutter and remove from the Site.

3.24.6 DRAINAGE CONTROL. Contractor shall provide for the drainage of storm

(v) General Conditions

water and such water as may be applied or discharged on the Site in performance of the Work. Drainage facilities shall be adequate to prevent damage to the Work, Site, and adjacent property. Also, drainage facilities shall be constructed to minimize the potential pollution to the ocean.

Existing drainage channels and conduits shall be cleaned, enlarged, or supplemented as necessary to carry all increased runoff attributable to Contractor's operations. Dikes shall be constructed as necessary to divert increased runoff from entering adjacent property (except in natural channels), to protect District's private property and utility owner's facilities and the Work, and to direct water to drainage channels or conduits. Retention of drainage on the Site shall be provided as necessary to prevent downstream flooding.

### 3.24.7 SOUND CONTROL.

.1 Contractor shall comply with all local sound control and noise level rules, regulations and ordinances which apply to any Work performed pursuant to the Construction Contract, except as modified in the Special Provisions and Technical Specifications.

.2 Each internal combustion engine, used for any purpose on the job or related to the job, shall be equipped with a muffler of a type recommended by the manufacturer. No internal combustion engine shall be operated on the Project without said muffler. The noise level from Contractor's operations, between the hours of 7:00 A.M. and 6:00 P.M., shall not exceed 86 DBA at a distance of 15 meters (50 feet). This requirement in no way relieves Contractor from responsibility for complying with local ordinances regulating noise level.

.3 The noise level requirement shall apply to all equipment on the job or related to the job, including but not limited to trucks, transit mixers or transient equipment that may or may not be owned by Contractor. The use of loud sound signals shall be avoided in favor of light warnings except those required by safety laws for the protection of personnel.

.4 Prior to starting construction, all equipment to be used on the Project shall be inspected and tested for compliance with the requirements of this Project. Sound blankets or other sound mitigation equipment approved by the Construction Manager shall be required to bring equipment into compliance with the requirements of this Project.

.5 Full compensation for conforming to the requirements of this provision shall be considered as included in the prices paid for the various contract items of Work involved and no additional compensation will be allowed therefor.

3.24.8 SPECIAL HAZARDOUS SUBSTANCES AND PROCESSES. Contractor acknowledges that it is aware of and in compliance with the provisions of the Hazard Communication Standards (California Code of Regulations, Title 8,



Section 5194). Contractor shall, at the request of the Construction Manager, demonstrate that Contractor is in complete compliance with the Hazard Communication Standards. In addition, Contractor shall, at the request of the Construction Manager, provide to the Construction Manager a material safety data sheet and a copy of the product label for any product handled or used by Contractor on District property or in an area where a District employee is working. Contractor shall contact the District's "Household Hazardous Waste Facility" regarding the intent to dispose of any materials containing asbestos or any petroleum-contaminated soil.

---

## **ARTICLE 4 – ADMINISTRATION OF THE CONTRACT**

### **4.1 CONTRACT ADMINISTRATION BY DISTRICT, DESIGN CONSULTANT AND CONSTRUCTION MANAGER**

4.1.1 District and the Construction Manager will provide administration of the Construction Contract as provided in the Contract Documents.

4.1.2 No actions taken by District, Construction Manager or Design Consultant shall relieve Contractor of its obligations as described in the Contract Documents.

4.1.3 The Construction Manager will be present on the Site, as is convenient or necessary in the sole discretion of the Construction Manager, during the performance of the Work primarily for the purposes of providing administration, inspection and expediting communications between District, Design Consultant and Contractor.

4.1.4 Neither District, Design Consultant nor Construction Manager will have control over, will be in charge of, or will be responsible for construction means, methods, techniques, safety, sequences or procedures or for safety precautions and programs in connection with the Work, all of which are the sole responsibility of Contractor.

4.1.5 Unless otherwise provided in the Contract Documents or when direct communications have been specifically authorized, communications between Contractor and District or Design Consultant shall be in writing through Construction Manager. Communications by Contractor, Subcontractors and Sub-subcontractors with Separate Contractors shall be through the Construction Manager. Contractor shall not rely on oral or other non-written communications.

4.1.6 Based on the Construction Manager's Site visits and evaluations of Contractor's Applications For Payment, the Construction Manager will review and recommend to District for District approval the amounts, if any, due Contractor.

4.1.7 Construction Manager will make recommendations to District to reject the Work, or any portion thereof, which does not conform to the Contract Documents. District alone shall have the authority to stop the Work or any portion thereof. Whenever District considers it necessary or advisable, District will have the authority to require additional inspection or testing of the Work in accordance with the Contract Documents, whether or not such Work is fabricated, installed or completed. However, no authority of District conferred by the Contract Documents nor any decision made in good faith either to exercise or not exercise such authority, nor any recommendation by the Construction Manager, shall give rise to a duty or responsibility of District or the Construction Manager to Contractor or its Subcontractors or Sub-subcontractors, of any Tier.

4.1.8 Construction Manager will have the authority to do the following:

(v) General Conditions

- (i) Conduct inspections in connection with Beneficial Occupancy or beneficial use of the District;
- (ii) Assist District in determining the dates of Substantial Completion and Final Completion.
- (iii) Review any records, written warranties and related documents required by the Contract Documents and assembled by Contractor; and
- (iv) Make recommendations to District for issuance of final payment upon Contractor's compliance with the requirements of the Contract Documents.

4.1.9 District, with the assistance of recommendations from the Design Consultant and/or Construction Manager, shall be the ultimate interpreter of the requirements of the Contract Documents and the judge of performance thereunder by Contractor. Such decisions by District will be final and binding upon Contractor.

## **4.2 CLAIMS**

As set forth in the Section 1.1.18, a Contractor Claim means a separate demand by a Contractor sent by registered mail or certified mail with return receipt requested, for one or more of the following: (A) a time extension, including, without limitation, for relief from damages or penalties for delay assessed by the District; (B) payment by the District of money or damages arising from work done by, or on behalf of, the Contractor pursuant to the Construction Contract and payment for which is not otherwise expressly provided or to which the claimant is not otherwise entitled; (C) payment of an amount that is disputed by the District.

### **4.2.1 Time period for submission of Contractor Claim.**

- (i) If a Contractor Claim involves an adjustment to the Contract Sum or to the Contract Time due to Extra Work, then the Claim arises upon issuance of a decision denying, in whole or in part, Contractor's Change Order Request. All other Claims arise when Contractor discovers, or should have discovered, the circumstances giving rise to the Claim (even if Contractor has not yet been damaged or delayed).
- (ii) A Contractor Claim that does not involve an adjustment to the Contract Sum or Contract Time for Extra Work may be asserted if, and only if, Contractor gives written notice of intent to file the Claim within five (5) Days of the date the Claim arises under Article 4.2.1. A written notice of intent to file a Claim shall be valid if, and only if, it identifies the event or condition giving rise to the Claim, states its probable effect, if any, with respect to Contractor's entitlement to an adjustment of the Contract Sum or Contract Time, and complies with the requirements of Article 4.2.3.

- (v) General Conditions

4.2.2 The claimant shall furnish reasonable documentation to support a Contractor Claim. The documentation is to include the following:

(i) A statement that it is a Contractor Claim and a request for a decision on the Contractor Claim;

(ii) A detailed description of the act, error, omission, Differing Site Condition, event or other circumstance giving rise to the Contractor Claim; and

(iii) If the Contractor Claim involves an adjustment to the Contract Sum or Contract Time for Extra Work, a statement demonstrating that a Change Order Request was submitted in a timely manner as required by Article 7.2. If the Contractor Claim does not involve an adjustment to the Contract Sum or Contract Time for Extra Work, a statement demonstrating that a notice of intent to file the Contractor Claim was submitted in a timely manner as required by Article 4.2.2.

(iv) A detailed justification for any remedy or relief sought by the Contractor Claim, including, without limitation:

a. A detailed cost breakdown in the form required for submittal of Change Order Requests and subject to the prohibition in Article 7.2.14 relating to calculations based on total cost methodology.

b. Copies of actual job cost records demonstrating that the costs have been incurred.

c. If the Contractor Claim is based on an error, omission, conflict or ambiguity in the Contract Documents: (i) a sworn statement by Contractor and any Subcontractors or Sub-subcontractors involved in the Claim, to the effect that the error, omission, conflict or ambiguity was not discovered prior to submission of the Bid, or (ii) if not discovered, a statement demonstrating that the error, omission, conflict or ambiguity could not have been discovered by Contractor, its Subcontractors or Sub-subcontractors in exercise of the degree of care required of them under the Contract Documents for review of the Bid Documents prior to submission of the Bid.

(v) If the Contractor Claim involves a request for adjustment of the Contract Time, written documentation demonstrating that Contractor has complied with the requirements of the Contract Documents pertaining to proving the right to an extension of time and demonstrating that Contractor is entitled to an extension of time under the Contract Documents.

(vi) A written certification signed by a responsible managing officer of Contractor's organization, who has the authority to sign subcontracts and purchase orders on behalf of Contractor and who has personally investigated

(v) General Conditions

and confirmed the truth and accuracy of the matters set forth in such certification, in the following form:

*I hereby certify under penalty of perjury under the laws of the State of California that I am a managing officer of [Contractor's name] and that I have reviewed the Claim presented herewith on Contractor's behalf and/or on behalf of [Subcontractor's/Sub-subcontractor's name(s)] and that the following statements are true and correct.*

*(i) The facts alleged in or that form the basis for the Claim are true and accurate; and,*

*(ii) Contractor does not know of any facts or circumstances, not alleged in the Claim, that by reason of their not being alleged render any fact or statement alleged in the Claim materially misleading; and,*

*(iii) Contractor has, with respect to any request for money or damages alleged in or that forms the basis for the Claim, reviewed the job cost records (including those maintained by Contractor and by any Subcontractor or Sub-subcontractor, of any Tier, that is asserting all or any portion of the Claim) and confirmed with reasonable certainty that the Losses or damages suffered by Contractor and/or such Subcontractor or Sub-subcontractor were in fact suffered in the amounts and for the reasons alleged in the Claim; and,*

*(iv) Contractor has, with respect to any request for extension of time or claim of Delay, disruption, hindrance or interference alleged in or that forms the basis for the Claim, reviewed the job schedules (including those maintained by Contractor and by any Subcontractor or Sub-subcontractor, of any Tier, that is asserting all or any portion of the Claim) and confirmed on an event-by-event basis that the delays or disruption suffered by Contractor and/or such Subcontractor or Sub-subcontractor were in fact experienced for the durations, in the manner, and with the consequent effects on the time and/or sequence of performance of the Work, as alleged in the Claim; and,*

*(v) Contractor has not received payment from District for, nor has Contractor previously released District from, any portion of the Claim.*

Signature:

Name:

Title:

*Company:*

*Date:*

4.2.3 Notwithstanding the making of any Contractor Claim or the existence of any dispute regarding any Contractor Claim, unless otherwise directed by District, Contractor shall not delay, slow, or stop performance of the Work, but shall diligently proceed with performance in accordance with the Contract Documents and District will continue to make payments as required by the Contract Documents.

4.2.4 All Contractor Claims and supporting documentation and certifications must be filed within thirty (30) Days after the Contractor Claim arises. No Contractor Claims shall be filed after the final payment has been issued unless otherwise permitted by law.

4.2.5 All Contractor Claims and supporting documentation must be sent by registered mail or certified mail with return receipt requested.

4.2.6 Time Period for Response.

(i) Upon receipt of a Contractor Claim pursuant to this Section 4.2, the District shall conduct a reasonable review of the claim and, within a period not to exceed forty-five (45) days, shall provide the claimant a written statement identifying what portion of the claim is disputed and what portion is undisputed. Upon receipt of a claim, the District and Contractor may, by mutual agreement, extend the time period provide in this Section 4.2.6(i).

(ii) If the District needs approval from its governing body to provide the claimant with a written statement identifying the disputed portion and the undisputed portion of the claim, and the governing body does not meet within the forty-five (45) days or within the mutually agreed to extension of time following receipt of a claim sent by registered mail or certified mail, return receipt requested, the District shall have up to three (3) days following the next duly publicly noticed meeting of the governing body after the forty-five (45) day period, or extension, expires to provide the claimant a written statement identifying the disputed portion and the undisputed portion.

(iii) Any payment due on an undisputed portion of the claim shall be processed and made within 60 days after the District issues its written statement. If the District fails to issue a written statement, Section 4.2.9 shall apply.

4.2.7 Meet and Confer Conference. If the claimant disputes the District's written response, or if the District fails to respond to a claim issued pursuant to Section 4.2 within the time prescribed, the claimant may demand in writing and an informal conference to meet and confer for settlement of the issue in dispute. Upon receipt

(v) General Conditions

of a demand in writing sent by registered mail or certified mail, return receipt requested, the District shall schedule a meet and confer conference within 30 days for settlement of the dispute.

#### 4.2.8. Mediation.

(i) Within ten (10) business days following the conclusion of the meet and confer conference, if the claim or any portion of the claim remains in dispute, the District shall provide the claimant a written statement identifying the portion of the claim that remains in dispute and the portion that is undisputed. Any payment due on an undisputed portion of the claim shall be processed and made within sixty (60) days after the public entity issues its written statement. Any disputed portion of the claim, as identified by the contractor in writing, shall be submitted to nonbinding mediation, with the District and the claimant sharing the associated costs equally. The District and the claimant shall mutually agree to a mediator within ten (10) business days after the disputed portion of the claim has been identified in writing. If the parties cannot agree upon a mediator, each party shall select a mediator and those mediators shall select a qualified neutral third party to mediate with regard to the disputed portion of the claim. Each party shall bear the fees and costs charged by its respective mediator in connection with the selection of the neutral mediator. If mediation is unsuccessful, the parts of the claim remaining in dispute shall be subject to applicable procedures outside this section.

(ii) For purposes of this section, mediation includes any nonbinding process, including, but not limited to, neutral evaluation or a dispute review board, in which an independent third party or board assists the parties in dispute resolution through negotiation or by issuance of an evaluation. Any mediation utilized shall conform to the timeframes in this section.

(iii) Unless otherwise agreed to by the District and the contractor in writing, the mediation conducted pursuant to this section shall excuse any further obligation under Public Contract Code Section 20104.4 to mediate after litigation has been commenced.

(iv) In the event mediation does not resolve the parties' dispute, the parties shall comply with the binding Arbitration provisions set forth in Section 14.4.4 of the Construction Contract.

4.2.9 Failure by the District to respond to a Construction Claim within the time periods described in this subdivision or to otherwise meet the time requirements of this Section 4.2 shall result in the Construction Claim being deemed rejected in its entirety. A Construction Claim that is denied by reason of the District's failure to have responded to a claim, or its failure to otherwise meet the time requirements of this section, shall not constitute an adverse finding with regard to the merits of the claim or the responsibility or qualifications of the claimant.

(v) General Conditions

4.2.10 Amounts not paid in a timely as required by this section shall bear interest at 7 percent (7%) per annum.

4.2.11 If a subcontractor or a lower tier subcontractor lacks legal standing to assert a claim against the District because privity of contract does not exist, the Contractor may present to the District a claim on behalf of a subcontractor or lower tier subcontractor. A subcontractor may request in writing, either on his or her own behalf or on behalf of a lower tier subcontractor, that the Contractor present a claim for work which was performed by the subcontractor or by the lower tier subcontractor on behalf of the subcontractor. The subcontractor requesting that the claim be presented to the District shall comply with the Agreement, including the General Conditions, and shall furnish reasonable documentation to support the Construction Claim. Within 45 days of the receipt of this written request, the Contractor shall notify the subcontractor in writing as to whether the Contractor presented the claim to the District and, if the Contractor did not present the claim, provide the subcontractor with a statement of reasons for not having done so.

4.2.12 There shall be no waiver of any of the rights set forth in this Section 4.2; provided, however, that (i) upon receipt of a Construction Claim, the parties may mutually agree to waive, in writing, mediation and proceed directly to the commencement of a civil action or binding arbitration, as applicable; and (ii) the District may prescribe reasonable Change Order, Construction Claim, and Dispute Resolution Procedures and requirements in addition to the provisions of this section, so long as the contractual provisions do not conflict with or otherwise the timeframes and procedures set forth in Public Contract Code Section 9204.

---



## **ARTICLE 5 – SUBCONTRACTORS**

### **5.1 CONTRACTOR'S AWARD OF SUBCONTRACTS**

5.1.1 Contractor shall perform, with its own employees, Work amounting to at least 50 percent of the Contract Sum except that any designated "Specialty Items" may be performed by subcontract and the amount of any such "Specialty Items" so performed may be deducted from the Contract Sum before computing the amount required to be performed by Contractor with its own employees. "Specialty Items" are identified in the Bid Documents. Where an entire item is subcontracted, the value of Work subcontracted will, where no prices are provided, be based on the unit price and when a portion of an item is subcontracted, the value of Work subcontracted will be based on the estimated percentage of the unit price. Such percentages will be determined from information submitted by Contractor, and subject to approval by the Construction Manager.

5.1.2 Unless otherwise stated in the Contract Documents, Contractor shall submit in writing, prior to entering into any subcontract agreements, the company name, address, telephone and facsimile numbers, point-of-contact and contractor's license number of all Subcontractors proposed for the Work that are changed from those previously listed in Contractor's Bid. Any Subcontractor may be disqualified if District or the Construction Manager determines that such Subcontractor fails to meet the requirements of the Contract Documents or for any other appropriate reason. If District or the Construction Manager has reasonable objections to a person or entity proposed by Contractor, Contractor shall propose an alternate party to whom District and the Construction Manager have no reasonable objection.

5.1.3 Contractor shall comply with the Subletting and Subcontracting Fair Practices Act, California Public Contract Code, Sections 4100 through 4114. Nothing herein shall be deemed to entitle Contractor, without the written approval of District, to substitute other Subcontractors for those named in Contractor's List of Subcontractors contained in the completed Bid; and, except with such approval, no such substitution shall be made. Should Contractor violate any of the provisions of the Subletting and Subcontracting Fair Practices Act, such violation shall be deemed a violation of the Construction Contract, entitling District, without limitation to any other rights or remedies under the law, to suspend or terminate the Construction Contract.

5.1.4 Except as hereinafter provided, any increase in the cost of the Work resulting from the replacement or substitution of a Subcontractor, shall be borne solely by Contractor and without any adjustment in Contract Sum or Contract Time. However, if a replacement or substitution of any Subcontractor is made as a result of a request of District or the Construction Manager for any reason other than failure of such Subcontractor to meet the requirements of the Contract Documents or a request by Contractor for substitution, the Contract Sum only,

and not the Contract Time, shall be subject to adjustment pursuant to the Change Order provisions of the Contract Documents for the amount of the increase or decrease in the original subcontract amount, with no additional sum for Contractor Markup. In such cases and at the request of District, the replacement Subcontractor shall be selected through a competitive bidding process acceptable to District.

5.1.5 Where a hearing is held pursuant to the provisions of the California Public Contract Code Division 2, Part 1 – Chapter 4 (commencing with Subparagraph 4100), by the awarding authority or a duly appointed hearing officer, District's representative shall prepare and certify a statement of all costs incurred by District for investigation and conduct of the hearing, including the costs of any hearing officer and reporter appointed. The statement shall then be sent to Contractor who shall reimburse District for such costs. If not paid separately, such reimbursement may be deducted from any money due and owing to Contractor.

## **5.2 SUBCONTRACTUAL RELATIONS**

5.2.1 Prior to the execution of each subcontract agreement, Contractor shall make available to each proposed Subcontractor, copies of the Contract Documents to which the Subcontractor will be bound, including the provisions for dispute resolution. Within thirty (30) Days of the Notice To Proceed, Contractor shall provide District with a complete listing of all Subcontractors, which shall include, but not be limited to, the Work contracted for, Subcontractor's name, address, telephone and facsimile numbers, form for doing business (i.e., sole proprietor, corporation, partnership), point-of-contact and Subcontractor's license classification and number.

5.2.2 Any part of the Work performed for Contractor by a first Tier Subcontractor shall be pursuant to a written subcontract. Each such subcontract shall require that the Subcontractor:

- (i) Perform the Work in accordance with the terms of the Contract Documents.
- (ii) Assume toward Contractor all the obligations and responsibilities which Contractor assumes towards District by the Contract Documents.
- (iii) Preserve and protect the rights of District under the Contract Documents with respect to the Work to be performed by the Subcontractor so that subcontracting thereof will not prejudice such rights.
- (iv) Waive all rights that the Subcontractor may have against District for damages caused by fire or other perils covered by builder's risk property insurance carried by Contractor or District, except for such rights Subcontractor may have to the proceeds of such insurance held by District under Article 11 of these General Conditions.

(v) General Conditions

(v) Afford District and entities and agencies designated by District the same rights and remedies with respect to access to and the right to audit and the right to copy at District's cost all of the Subcontractor's books, records, contracts, correspondence, instructions, drawings, receipts, vouchers, purchase orders and memoranda relating to the Work and requiring the Subcontractor to preserve all such records and other items for a period of at least three (3) years after Final Completion.

(vi) Recognize the rights of District under Article 5.3, Contingent Assignment of Subcontracts, including, without limitation, District's right to elect to accept assignment of the subcontract and to retain Subcontractor pursuant to the terms of the subcontract, to complete the unperformed obligations under the subcontract and, if requested by District, to execute a written agreement on terms acceptable to District confirming that the Subcontractor is bound to District under the terms of the subcontract.

(vii) Submit Applications for payment, requests for Change Orders and extensions of time and Claims, and to comply with all other notice and submission requirements of the Contract Documents, sufficiently in advance to allow Contractor time to comply with its obligations under the Contract Documents.

(viii) Purchase and maintain insurance in accordance with the requirements of the Contract Documents and reserving the right to Owner to purchase, in its sole discretion, such insurance pursuant to an Owner Controlled Insurance or other form of Wrap-Up Program.

(ix) Defend and indemnify the Indemnitees listed in Article 3.21 on the same terms.

(x) Agree to participate in the dispute resolution procedures specified in the Contract, at the election of District.

5.2.3 Contractor shall promptly, after execution, furnish to District true, complete, and executed copies of all subcontracts, change orders and modifications thereto. Progress payments shall not be made for items of Work for which District has not received executed subcontracts or Change Orders.

5.2.4 Nothing contained in the Contract Documents shall create any contractual relationship between any Subcontractor and District, except when, and only to the extent that, District elects to accept the assignment of the subcontract with such Subcontractor pursuant to Article 5.3.

5.2.5 District and the Construction Manager shall have the right to communicate with Contractor's Subcontractors and Sub-subcontractors with respect to matters that are related to Contractor's performance of its obligations under the Contract Documents. Contractor shall be provided with

(v) General Conditions

a copy of all such written communications. Such communications shall not create or be interpreted as creating any contractual relationship between District or the Construction Manager and any such Subcontractor or Sub-subcontractor.

### **5.3 CONTINGENT ASSIGNMENT OF SUBCONTRACTS**

5.3.1 In the event of any suspension or termination of the Construction Contract, Contractor is hereby deemed to have assigned to District all its interest in contracts with Subcontractors now or hereafter entered into by Contractor for performance of any part of the Work. The assignment will be effective upon acceptance by District in writing and only as to those contracts which District designates in writing. District may accept, at its sole election, said assignment at any time during the course of the Work and prior to Final Completion in the event of a suspension or termination of Contractor's rights under the Contract Documents. Such assignment is part of the consideration to District for entering into the Contract with Contractor and may not be withdrawn prior to Final Completion.

---

**ARTICLE 6 -**  
**CONSTRUCTION BY DISTRICT OR BY SEPARATE CONTRACTORS**

**6.1 DISTRICT'S RIGHT TO PERFORM CONSTRUCTION AND TO AWARD SEPARATE CONTRACTS**

6.1.1 District reserves the right to award separate contracts for, or to perform with its own forces as provided for by law, construction or operations related to the Work or other construction or operations at or affecting the Site, including portions of the Work which have been deleted by modification. Contractor shall cooperate with District's forces and Separate Contractors.

6.1.2 District shall provide coordination of the activities of District forces and of each Separate Contractor with the Work of Contractor. Contractor shall participate with District and Separate Contractors in joint review of construction schedules and Project requirements when directed to do so. Contractor shall make necessary revisions to the Construction Schedule after such joint review.

6.1.3 Without limitation upon any of the rights or remedies of District under the Contract Documents or under law arising from a default by Contractor, in the event that Contractor fails to have personnel on Site to supervise the Work, District shall have the right, in its sole discretion, but not the responsibility, upon twenty-four (24) hours' telephonic notice to Contractor, to provide such supervision on a temporary basis. Contractor shall, notwithstanding District's providing such temporary supervision, remain solely responsible for all actions of its personnel and Subcontractors and shall defend and indemnify District in accordance with Article 3.21 against any Losses arising therefrom. District shall have the right, in its discretion, to deduct from the sums owing to Contractor the reasonable cost of such temporary supervision.

**6.2 MUTUAL RESPONSIBILITY**

6.2.1 Contractor shall be responsible for affording Separate Contractors reasonable opportunity for introduction and storage of their materials and equipment and performance of their activities. Contractor shall schedule and coordinate its construction and operations with the construction and operations of Separate Contractors as required by the Contract Documents.

6.2.2 If a portion of the Work is dependent upon the proper execution or results of other construction or operations by Separate Contractors, Contractor shall inspect such other construction or operations before proceeding with that portion of the Work. Contractor shall promptly report to District apparent discrepancies or defects which render the other construction or operations unsuitable to receive the Work. Unless otherwise directed by District, Contractor shall not proceed with the portion of the Work affected until apparent discrepancies or defects have been corrected. Failure of Contractor to so report within a reasonable time after discovering such discrepancies or defects shall constitute an acknowledgment

that the other construction or operations by District or Separate Contractors is suitable to receive the Work, except as to defects not then reasonably discoverable.

6.2.3 In the event of Delays, improperly timed activities or Defective Work, the costs of such occurrences shall be borne by the party responsible therefore.

6.2.4 If Contractor wrongfully causes damage to completed or partially completed construction or to property of District or Separate Contractors, Contractor shall promptly remedy damage.

6.2.5 If a dispute, or other matters in question arise between Contractor and a Separate Contractor, these occurrences shall be subject to the provisions of Section 14 (Dispute Resolution) of the Construction Contract. Contractor shall immediately notify the Construction Manager in writing and within seventy-two (72) hours of such occurrences.

### **6.3 DISTRICT'S RIGHT TO CLEAN UP**

6.3.1 If a dispute arises between Contractor and Separate Contractors as to the responsibility under their respective contracts for maintaining the Site and surrounding areas free from waste materials and rubbish, District may clean up and allocate the cost between those firms it deems, in its sole discretion, to be responsible.

---

## **ARTICLE 7 – CHANGES**

### **7.1 CHANGES**

7.1.1 District may, at any time and without notice to Contractor's sureties, order Changes in the Work without invalidating the Construction Contract and without relieving sureties of their obligations to District.

7.1.2 District shall be entitled to a deductive adjustment in the Contract Sum for Changes that involve Deleted Work that result in a reduction in the cost of Contractor's performing the Work and shall be entitled to an adjustment reducing the Contract Time for Deleted Work that results in Contractor's being able to complete the Work earlier than the Contract Time.

7.1.3 Unless such rights have been waived and provided that Contractor has complied with the requirements of the Contract Documents with respect to, without limitation, complete and timely submission of all notices, requests and supporting documentation, Contractor shall be entitled to an additive adjustment to the Contract Sum for Changes that involve Extra Work and an adjustment extending the Contract Time for Delays for which Contractor is entitled under the Contract Documents to an extension of time.

7.1.4 District shall have the right to require performance of Changes that result in Extra Work on a lump sum basis, a unit price basis or a time and material basis, all as hereinafter more particularly described.

7.1.5 Changes may be ordered by District or the Construction Manager in writing by issuance of an agreed or unilateral Change Order or a Field Order. Contractor shall not be entitled to an adjustment of the Contract Sum or Contract Time for Changes that are not authorized by a Change Order or Field Order signed by District or Construction Manager. It is of essence to this agreement that all Changes in the Work that are the basis of an adjustment to the Contract Sum or Contract Time must be authorized in advance, in writing, by District or Construction Manager. Accordingly, no verbal directions, course of conduct between the parties or express or implied Acceptance of Changes or Work, and no claim that the Owner has been unjustly enriched (whether or not there has been such enrichment) shall be the basis for an adjustment to the Contract Sum or Contract Time if Contractor has not obtained advance written authorization to perform the Change in the manner required by this provision.

7.1.6 District reserves the absolute right to make whatever Changes that it determines in its sole discretion are necessary and in its best interests and under no circumstances shall the number (individual or cumulative value) or scope of Changes become a basis for Contractor to claim that the Construction Contract has been rescinded, terminated, abandoned or should be reformed nor shall such circumstances be the basis for Contractor, or any Subcontractor or Sub-subcontractor, of any Tier, to recover any compensation or damages not

permitted by, or in excess of that allowed under, the Contract Documents.

7.1.7 District shall have authority to order minor changes in the Work not involving an adjustment in the Contract Sum or an extension of the Contract Time and not inconsistent with the intent of the Contract Documents. Such changes shall be effected by written order, and shall be binding on District and Contractor. Contractor shall carry out such written orders promptly.

## **7.2 CHANGE ORDERS AND CHANGE ORDER REQUESTS**

7.2.1 Contractor may request adjustments to the Contract Sum or Contract Time if, and only if, Contractor follows the procedures specified in the Contract Documents, including, without limitation, the procedures set forth in this Article 7.2. If requested by District or Construction Manager, or if Contractor believes that it is entitled to an adjustment of the Contract Sum or Contract Time due to Extra Work, Contractor shall submit to District and the Construction Manager a Change Order Request in writing within seven (7) Days after the occurrence of the circumstances giving rise thereto setting forth the circumstances that are the basis of the Change and Contractor's estimate of the additional Allowable Costs associated with the Extra Work in the form required by the General Conditions, Special Provisions and Technical Specifications and Contractor's proposed adjustments of the Contract Sum and the Contract Time, if any, for performing the Extra Work. If Contractor's Change Order Request includes a request for adjustment to the Contract Time, it shall include such information as required by the General Conditions and/or Special Provisions and Technical Specifications, including but not limited to a "Fragnet" or "time impact analysis," which identifies all critical and non-critical activities affected by the Change Order Request and showing logic ties into all existing affected activities noted on the latest approved, updated Construction Schedule.

7.2.2 In the event that the parties are unable to agree as to the reasonable cost and time to perform a Change to the Work based upon Contractor's Change Order Request and District does not elect to have the Change in the Work performed on a time and material basis, District may, in its discretion, either order performance of the Work by Field Order or make a unilateral determination of the reasonable additions or savings in cost and time attributable to the Change in the Work, based upon District's estimate, Contractor's submission or a combination thereof. A Change Order shall be issued for the amounts of cost and time determined by District and shall be promptly performed by Contractor. District's unilateral determination shall become binding upon Contractor unless Contractor submits a Contractor Claim in writing to District within twenty-one (21) Days of the issuance of the Change Order. No dispute, disagreement, nor failure of the parties to reach agreement regarding the amount, if any, of any adjustment to the Contract Sum or Contract Time due to a Change in the Work, shall relieve Contractor from the obligation to proceed with performance of the Work, including, without limitation, performance of the Change, promptly and expeditiously.

(v) General Conditions



7.2.3 Changes involving Extra Work that District elects to have performed on a time and material basis shall be performed, whether by Contractor's forces or the forces of Subcontractors or Sub-Subcontractors, based on actual Allowable Costs in performing the Change in the Work and with mark-ups in accordance with Section 7.3 of the Contract. Contractor shall submit on a daily basis to the Construction Manager daily time and material tickets to include the identification number assigned to the Change; the location and description of the Change; the classification of labor employed (and names and social security numbers if requested); the materials used; the equipment rented (not tools); and such other evidence of cost as the Construction Manager may require. The Construction Manager may require authentication of all time and material tickets and invoices by persons designated by the Construction Manager for such purpose. The failure of Contractor to secure any required authentication shall, if District elects to treat it as such, constitute a waiver by Contractor of any right to adjustment of the Contract Sum for the cost of all or that portion of the Extra Work covered by a non-authenticated ticket or invoice. The adjustment to the Contract Sum for the Extra Work will be based on the accumulation of Allowable Costs as provided in Article 7.2.5 below. It is Contractor's responsibility to review the Change Order Request invoicing of Contractor and Subcontractors and Sub-subcontractors for accuracy of Subcontractor Markups as defined in Section 7.3 (Compensation to Contractor) of the Construction Contract.

7.2.4 Adjustments to the Contract Sum for Changes for which Contractor is entitled to an adjustment of the Contract Sum by Change Order shall be computed at District's sole election on the basis of one or more of the following:

- (i) Unit prices stated in the Contract Documents or agreed upon by District and Contractor, which unit prices shall be deemed to include Contractor Markup and Subcontractor/Sub-subcontractor Markups permitted by Section 7.3 (Compensation for Extra or Deleted Work) of the Construction Contract.
- (ii) A lump sum agreed upon by District and Contractor, based on the estimated Allowable Costs and Contractor Markup and Subcontractor/Sub-Subcontractor Markup computed in accordance with Section 7.3 (Compensation for Extra or Deleted Work) of the Construction Contract.
- (iii) Contractor's Allowable Costs, plus Contractor Markup and Subcontractor/Sub- subcontractor Markups applicable to such Extra Work computed in accordance with Section 7.3 (Compensation for Extra or Deleted Work) of the Construction Contract.

7.2.5 Allowable Costs shall mean only those costs listed in, and substantiated and documented in accordance with, this provision and that are not disallowed pursuant to Articles 7.2.6, 7.2.11 or other provisions of the Contract Documents. Allowable Costs are the actual costs necessarily incurred by Contractor and all

Subcontractors and Sub- subcontractors, of every Tier, that actually perform the Extra Work caused by the Change(s) and that are incurred in the direct performance of the Extra Work or that are saved by reason of Deleted Work, and are strictly limited to the following:

.1 Labor. The actual straight-time (and the premium time portion of overtime, if approved in writing in advance by District or the Construction Manager) wages or salaries for employees employed at the Site, or at fabrication sites off the Site, plus employer payments collectively referred to as "Fringe Benefits and Payroll Taxes," of payroll, taxes and insurance, health and welfare pension, vacation, apprenticeship funds, and other direct costs resulting from Federal, State or local laws, as well as assessments or benefits required by lawful collective bargaining agreements. The use of a labor classification, which would increase the Allowable Costs will not be permitted unless Contractor establishes the necessity for such additional costs. Labor costs for equipment operators and helpers shall be payable under this provision only when such costs are not included in the invoice for equipment rental.

.2 Material. The cost of materials and consumable items which are furnished and incorporated into the Work at invoice or lowest current price at which such materials are locally available and delivered to the Site in the quantities involved, plus sales tax, freight, and delivery. District reserves the right to approve materials and sources of supply, or to supply materials to Contractor, if necessary, for the Work. No markup shall be applied to any material provided by District. Material re-stocking charges shall be limited to 5% of the amount of material. All discounts, rebates, and refunds from the sale of surplus materials and consumable items shall accrue to District, and Contractor shall make provision so that they may be obtained.

.3 Tool and Equipment Rental. Rental charges for necessary machinery and equipment, whether owned or hired, as authorized in writing by District or the Construction Manager, exclusive of hand tools. No payment will be made for the use of tools that have a replacement value of \$500 or less. When the equipment is owned by Contractor, the rental rate shall be as listed for such equipment in the California Department of Transportation publication entitled "Labor Surcharge and Equipment Rental Rates," which is in effect on the date the Work is accomplished. When equipment is not listed in said publication, the rate to be paid shall be as herein defined, or a suitable rental rate for such equipment will be established by the Construction Manager. Regardless of ownership, the rates to be used in determining equipment rental cost shall not exceed listed rates prevailing locally at equipment rental agencies or distributors at the time the work is performed. The rental rates paid shall include the cost of fuel, oil, lubrication, supplies, small tools, necessary attachments, repairs and maintenance of any kind, depreciation, storage, insurance, and all incidentals. If equipment is used intermittently, when not in use it shall be returned to its rental source unless Contractor elects to keep it at the Site at no expense to District.

The reported rental time for equipment already at the Site shall be the duration of its use on the Extra Work, commencing at the time it is first put into actual operation on the Extra Work, plus the time required to move it from its previous site and back, or to a closer site.

.4 Royalties and Permits. Costs of royalties and permits solely related to the Extra or Deleted Work.

.5 Insurance and Bonds. Additional costs of insurance and bonds, not to exceed two percent (2%) of the total of Parts .1 through .4, above.

7.2.6 Extra Work Costs shall not include any of the following, which are construed to be included in Contractor's Markup:

- (i) Superintendent(s).
- (ii) Assistant Superintendent(s).
- (iii) Project Engineer(s).
- (iv) Project Manager(s).
- (v) Scheduler(s).
- (vi) Estimator(s).
- (vii) Drafting or detailing.
- (viii) Small tools (with a replacement value under \$500).
- (ix) Home or field office expenses, including staff, materials, and supplies.
- (x) Trailer or storage rental and expense, whether on the Site or off the Site.
- (xi) Data processing personnel and equipment.
- (xii) Site fencing.
- (xiii) Utilities, including, without limitation, gas, electric, sewer, water, telephones.
- (xiv) Telephone, facsimile, e-mail and copier.
- (xv) Overhead, administrative, or general expenses of any kind.
- (xvi) Loss of efficiency or productivity, or other impact cost due to the effect of the Extra Work on the performance of other Work or the Work of other trades

(v) General Conditions

on the Project.

(xvii) Capital expenses, including interest on capital employed in connection with Extra Work.

(xviii) Legal costs.

(xix) Federal, State, or local income and franchise taxes.

(xx) Profit.

(xxi) Any Extra Work Costs incurred more than twenty (20) Days prior to submission by Contractor of its Change Order Request pursuant to Article 7.2.1.

(xxii) Cost of any item not specifically and expressly included in the items described in Article 7.2.5.

7.2.7 The term "Contractor Markup" shall mean the full amount of compensation for all costs and expenses including overhead and profit not included in the Allowable Costs, whether or not referred to in Article 7.2.5. Contractor Markup shall be computed as provided in Section 7.3 (Compensation for Extra or Deleted Work) of the Construction Contract.

(i) For Work to be omitted by Change Order, the reduction of the Contract Sum shall be computed on the basis of one or more of the following: Unit prices stated in the Contract Documents or agreed upon by District and Contractor.

(ii) A lump sum agreed upon by District and Contractor, based upon the estimated Allowable Costs that would have been incurred in performing the Deleted Work, plus Contractor Markup provided for in the Construction Contract.

(iii) A sum unilaterally determined by District, if District and Contractor cannot agree upon one or both of the methods described in paragraphs (i) or (ii), above.

7.2.8 No Contractor Claim for adjustment of the Contract Sum shall be allowed if asserted after final payment under the Construction Contract.

7.2.9 If anyone Change involves both Extra Work and Deleted Work in the same portion of the Work, the Contractor Markup to be added or credited will be based on the net difference between amount allowed for the Extra Work and Deleted Work.

7.2.10 The Contract Sum will be adjusted for Delay only if and to the extent allowed by the Contract for Compensable Delay. Contractor agrees to accept such adjustments in its compensation as its sole and exclusive remedy and

(v) General Conditions

recovery for Delay, disruption, hindrance, interference, loss of productivity, labor or material cost escalations, inefficiency, acceleration, impact costs associated with the effect of the Changes on the Work, extended or extraordinary overhead (direct or indirect) or other Losses or damages due to Delay, of any kind.

7.2.11 District has the right to increase or decrease the quantity of any unit price item for which an estimated quantity is stated in the Bid Documents.

7.2.12 The signing of a Change Order indicates that the parties have reached a full resolution, settlement and accord and satisfaction with respect to all Contractor Claims for cost and extensions of time that were asserted, or that could have been asserted, in connection with the Change, whether known or unknown at the time of execution of the Change Order, and that are related to the subject matter of the Change Order, including, without limitation, all Contractor Claims, costs or damages for Delay, disruption, hindrance, interference, extended or extraordinary direct and indirect overhead, multiplicity of Changes, loss of productivity, labor or material cost escalations, inefficiency, the impact of the Change on the Work, legal expenses, consultant costs, interest, lost profits or revenue, bond or insurance costs, currency fluctuations, changes in taxes or other related Claims, costs or damages. Change Orders shall be executed by Contractor without any express reservation of rights by Contractor to reserve for the future the right to assert or recover from District any such Claims, costs or damages.

7.2.13 Contractor's cost breakdowns submitted with its Change Order Requests (including, without limitation, requests for cost reimbursement for Delay, disruption, hindrance and interference associated with extras, Changes, additions or deletions) shall be itemized in a manner that, with mathematical certainty and without reliance upon probabilities or inferences, segregates the direct, actual reimbursable costs associated with each individual extra, Change, addition, deletion and (on an event-by-event basis) each individual Delay or disruption event. Change Order Requests shall not be based, in whole or in part, upon any methodology (such as total cost or modified total cost methodologies) that purports to calculate Contractor's additional costs of performance of the extra, Change, addition or deletion (including, without limitation, the additional costs of Delay, disruption or other impact) based on the difference between Contractor's total actual Project or line item costs and its original bid estimate for the Project or any original bid estimate line item. In connection with the foregoing, Contractor represents and warrants that it has the ability to generate and maintain complete and accurate cost accounting records that will reflect:

(i) The actual Allowable Costs incurred or saved for each individual item of Extra Work or Deleted Work; and

(ii) On an event-by-event basis, the effect of each Delay that forms the basis of each request for extension of time, regardless of their scope, number,

(v) General Conditions

complexity, cumulative effect or time of issuance or occurrence.

7.2.14 As a further condition of Contractor's right to an adjustment of the Contract Sum for Extra Work, Contractor must keep daily, detailed and accurate records itemizing each element of Extra Work Cost and shall provide substantiating records and documentation, including timecards, invoices and delivery tickets listing all labor, materials, and equipment involved for that day. Failure to submit such records daily shall waive any rights for recovery of Allowable Costs for that day. Such records and documentation shall be submitted to and Approved by Construction Manager on a daily basis.

### **7.3 FIELD ORDERS**

7.3.1 Upon receipt of a Field Order, Contractor shall, within a reasonable time, proceed with the Work described in the Field Order. If the Field Order involves Extra Work and sets forth a determination for adjustment of the Contract Sum or Contract Time with which Contractor disagrees, Contractor shall advise District of its agreement or disagreement in writing within seven (7) Days of such receipt. Failure by Contractor to provide such written notice shall result in its waiving any right to adjustment of the Contract Sum or Contract Time on account thereof.

### **7.4 DISPUTES REGARDING CHANGES**

7.4.1 Provided that District pays to Contractor all undisputed sums due under the Contract Documents for Work performed under Change Orders, Contractor shall not delay, slow, interrupt, or suspend the performance of any Work or any Change because of a dispute between the parties with respect to an adjustment in the Contract Sum or Contract Time.

---

## **ARTICLE 8 – CONTRACT TIME**

### **8.1 COMMENCEMENT OF THE WORK**

8.1.1 Commencement of the Work shall begin on the date specified in the Notice to Proceed.

### **8.2 PROGRESS AND COMPLETION**

8.2.1 By signing the Contract, Contractor represents to District that the Contract Time is reasonable for performing the Work and that Contractor is able to perform the Work within the Contract Time.

.1 The Construction Schedule may reflect a period of performance that is shorter than the Contract Time; provided however, that the difference shall be deemed as float and nothing in this provision or in any other provision of the Contract Documents shall be construed as creating any contractual right, express or implied, on the part of Contractor to finish the Project earlier than the Contract Time and under no circumstances shall District be liable to Contractor for any costs, damages or compensation due to the inability of Contractor to complete the Work earlier than the Contract Time, regardless of the cause, including, without limitation, acts or omissions (intentional or negligent) of District.

.2 Contractor has included in its Bid price the costs of all Contractor and Subcontractor overhead (direct and indirect) and Special Provisions and Technical Specifications, including but not limited to all Project staff, temporary facilities, temporary utilities, and home office overhead for the entire duration of the Contract Time. The above costs must be included in Contractor's Bid notwithstanding Contractor's anticipation of completion in fewer days than established by the Contract Time.

.3 No increase in the Contract Sum shall be made or granted for Compensable Delay if, for any reason including but not limited to Delay caused by District, Contractor completes the Work before expiration of the Contract Time.

.4 No reduction in the Contract Sum shall be made nor will Contractor be required to remain on the Project Site if the Work is completed before expiration of the Contract Time.

.5 The Construction Manager will schedule and hold weekly progress meetings and other meetings as determined by the Construction Manager. Contractor and/or Contractor's designee shall be present at each meeting. Contractor may also be required to request attendance by representatives of its suppliers, manufacturers, and Subcontractors.

8.2.2 Except by agreement or instruction of District in writing, Contractor shall not commence operations on the Site or elsewhere prior to the effective date of

(v) General Conditions

insurance required by Article 11 to be furnished by Contractor. Contractor's obligations to commence the Work and to complete the Work within the Contract Time shall not be changed by the effective date of such insurance.

8.2.3 Contractor shall proceed expeditiously with adequate forces and shall achieve Substantial Completion within the Contract Time. If District determines and notifies Contractor that Contractor's progress is such that Contractor will not complete the Work within the Contract Time, Contractor shall, immediately and at no additional cost to District, take all measures necessary, including working such overtime and additional shifts (other than District's normal working hours of 7:00 AM to 6:00 PM, Monday through Friday and 9:00 AM to 5:00 PM on Saturday), to ensure that the Work is Substantially Completed within the Contract Time. Upon receipt of such notice from District, Contractor shall immediately respond in writing setting forth a detailed plan for accelerating the Work in a manner acceptable to District. Contractor shall not be entitled to any reimbursement or payment of costs, expenses or damages incurred as a result of an acceleration of the Work that is performed pursuant to this provision. District may also take all necessary measures to ensure no further Delays to the Substantial Completion of the Work within the Contract Time. Contractor shall reimburse District, or District may withhold from payment due to Contractor, sums expended by District to perform such measures.

8.2.4. During unfavorable weather, wet ground or other unsuitable construction conditions, Contractor shall confine the operations to Work that will not be affected adversely by such conditions. No portion of the Work shall be constructed under conditions which would affect adversely the quality thereof or be detrimental to the quality of water discharges unless special means or precautions are taken by Contractor to perform the Work in a proper and satisfactory manner.

### **8.3 DELAY**

8.3.1 Contractor may make a Contractor Claim for an extension of the Contract Time, for an Excusable Delay or a Compensable Delay, subject to the following:

.1 In order to avoid double counting concurrent Delays, if an Excusable Delay and a Compensable Delay occur concurrently, the maximum extension of the Contract Time shall be the number of days from the commencement of the first Delay to the cessation of the Delay which ends last.

.2 If an Unexcused Delay occurs concurrently with either an Excusable Delay or a Compensable Delay, the maximum extension of the Contract Time shall be the number of Days, if any, by which the Excusable Delay or the Compensable Delay exceeds the Unexcused Delay.

.3 If an Unexcused Delay occurs concurrently with both an Excusable Delay and a Compensable Delay, the maximum extension of the Contract Time shall



be the number of Days, if any, by which the number of Days determined pursuant to Article 8.3.1.2 exceeds the number of Days of the Unexcused Delay.

8.3.2 As a condition precedent to Contractor's right to an extension of Time adjusting the Contract Time and the Contract Sum for Compensable Delay, it must provide written notice to District within seven (7) Days of the date that Contractor learned of the Delay or should have learned of the Delay in exercise of diligence and reasonable care, setting forth:

- (i) A description of the Delay;
- (ii) A statement that the Delay is critical to completion; and
- (iii) The probable effect of the Delay in terms of the number of Days' extension Contractor believes are required to the Contract Time.

It is agreed that the form, content, and timeliness of the written notice required by Article 8.3.2 is of the essence to District's ability to adequately monitor the progress of the Work, to differentiate between critical and non-critical Delays, and to prioritize its actions in a manner that is appropriately targeted to mitigate the effect of delays. Accordingly, Contractor agrees that failure to provide written notice in the manner required by Article 8.3.2 shall be conclusively deemed a waiver of the right to an adjustment of the Contract Sum and Contract Time on account thereby, regardless of whether the circumstances of the Delay may have been known or suspected by District or the Construction Manager and that no other form of notice (including, without limitation, meeting minutes, log entries or schedule updates) shall suffice as constituting notice to District in accordance with Article 8.3.2.

8.3.3 For a Compensable Delay, Contractor shall be entitled to an adjustment in the Contract Sum in a daily amount equal to Contractor's per diem amount as stated in the Contract multiplied by the number of Days of extension for Compensable Delay, if any, permitted under the Contract Documents. Such per diem amount shall be Contractor's sole and exclusive right and compensation to cover all costs and damages to Contractor and to its Subcontractors and Sub-subcontractors, of every Tier, for Compensable Delays and all other Claims for costs, acceleration, expenses, Losses, damage or compensation, of any kind, for additional supervision, administration, extended or extraordinary overhead (direct or home office), additional insurance or bond costs, loss of productivity, inefficiency, labor, wage, material or equipment escalation, or other costs, expenses or damages due to Delay, interruption, hindrance, compression, disruption, or the impact or ripple effect of Delays on the Work, are conclusively waived.

8.3.4 The parties agree that District's exercise of its rights to order Changes, whether or not resulting in Extra Work, regardless of the extent and number of

Changes, or to suspend the Work, is within the contemplation of the parties.

8.3.5 The determination of whether a Delay is an Excusable Delay, Compensable Delay or Unexcused Delay shall not be affected by the fact that any earlier Delay occurred, regardless of fault or causation.

8.3.6 All time limits stated in the Contract Documents are of the essence.

---

## **ARTICLE 9 – PAYMENTS AND COMPLETION**

### **9.1 SCHEDULE OF VALUES**

9.1.1 Within thirty (30) Days after signing the Contract, but in any event a maximum of ten (10) Days of receipt of the Notice to Proceed, Contractor shall submit to District through the Construction Manager a Schedule of Values reflecting cost breakdown of the Contract Sum in a form approved by the Construction Manager. The Schedule of Values shall itemize as separate line items the cost of each scheduled Work activity and all other costs, including warranties, Record Documents, insurance, bonds, overhead and profit, the total of which shall equal the Contract Sum and shall be made out in a form approved by the Construction Manager. The Schedule of Values, when approved by District, shall become the basis for determining the cost of Work requested on Contractor's Applications For Payment. Contractor shall submit a statement based upon this breakdown, and if required, itemized in such form and supported by such evidence as the Construction Manager may direct, showing Contractor's right to the payment claimed.

### **9.2 PROGRESS PAYMENT**

9.2.1 Subject to District's right of withholding under Article 9.4.2, District agrees to pay to Contractor within thirty (30) Days of receipt of an undisputed and properly submitted Application for Payment an amount equal to ninety-five percent (95%) of the sum of the following:

- (i) Construction Manager's determination of the value, expressed as a percentage of the Contract Sum, of the Work in permanent place that has been tested as of the end of the preceding month.
- (ii) Plus Construction Manager's determination of the value of materials suitably stored but not yet incorporated into the Work, subject to Article 9.3.6.
- (iii) Less amounts previously paid.

9.2.2 At any Time after 50% of the Work has been determined by District to be completed, if District determines in its sole discretion that satisfactory progress on the Work is being made, District may, in its sole discretion, make any of the remaining progress payments in accordance with the calculation in Article 9.2.1 based on 100% of District's determination of the value of the Work in place and of stored materials not incorporated.

9.2.3 Progress payments shall not be construed as District's Acceptance of any or all of the Work and shall not be a waiver of any or all rights District has under the Contract Documents.

### 9.3 APPLICATION FOR PAYMENT

9.3.1 At the end of each month, Contractor shall submit to District an itemized Application For Payment, requesting payment for Work as of the end of that month that is calculated in accordance with the formula for payment set forth in Article 9.2.1. The Application For Payment shall be prepared:

- (i) Utilizing the format as designated by District or the Construction Manager.
- (ii) Itemized in accordance with the Schedule of Values.
- (iii) Including such data substantiating Contractor's right to payment as District may reasonably require, such as invoices, certified payrolls, daily time and material records, and, if securities are deposited in lieu of retention pursuant to Article 9.5, a certification of the market value of all such securities as of a date not earlier than five (5) Days prior to the date of the Application For Payment.
- (iv) Showing itemized amounts for Change Orders, Modifications, and retention.

9.3.2 Applications For Payment shall not include requests for payment on account of Changes which have not been authorized by Change Orders or amounts Contractor does not intend to pay a Subcontractor because of a dispute or other reason.

9.3.3 If required by District, an Application For Payment shall be accompanied by all of the following:

- (i) A summary showing payments that will be made to Subcontractors covered by such application.
- (ii) Conditional waivers and releases of claims and stop notices from Contractor and each Subcontractor and Sub-subcontractor, of every Tier, listed in the current Application For Payment covering sums requested in the current Application For Payment.
- (iii) Unconditional waivers and releases of claims and stop notices, from Contractor and each Subcontractor and Sub-subcontractor, of every Tier, listed in the preceding Application For Payment covering sums disbursed pursuant to that preceding Application For Payment.

9.3.4 Contractor warrants that, upon submittal of an Application For Payment, all Work for which Certificates For Payment have been previously issued and payment has been received from District, shall be free and clear of all claims, stop notices, security interests and encumbrances in favor of Contractor, Subcontractors, Sub-subcontractors, of every Tier, or other persons or firms entitled to make claims by reason of having provided labor, materials or equipment relating to the Work.

- (v) General Conditions

9.3.5 The making of final payment shall constitute a waiver of all Claims by District except those arising from unsettled liens, faulty or Defective Work, failure of the Work to comply with the requirements of the Contract Documents or terms of any special guarantees required by the Contract Documents.

9.3.6 At the sole discretion of District, the Construction Manager may approve for inclusion in Contractor's Application For Payment the cost of materials to be incorporated in the Work but not yet incorporated in the Work and already delivered and suitably stored either at the Site or at some other appropriate location acceptable to District. In such case, Contractor shall furnish evidence satisfactory to District:

- (i) Of the cost of such materials.
- (ii) That such materials are under the exclusive control of Contractor, or if not, that title to the materials is in District, free of any lien or encumbrance and that the materials are safely and suitably stored in a bonded warehouse with appropriate insurance coverage satisfactory to District to cover any Loss.

Any payment pursuant to this provision shall not be construed as an inspection or acceptance of the materials nor shall it relieve Contractor of its continuing and sole responsibility for the care and protection of such materials, nor shall it relieve Contractor from sole responsibility for any loss or damage to the materials from any cause whatsoever nor act as a waiver of the right of District to require strict fulfillment by Contractor with all terms of the Contract Documents.

9.3.7 District shall have the right, in its sole discretion, to make payments of monies owing to Contractor by means of direct payment to Subcontractors or Sub-subcontractors, of any Tier of any unpaid work performed by any Subcontractor or Sub-subcontractor of any Tier, or by joint payment to Contractor and to Subcontractors or Sub-subcontractors, of any Tier. The making of such payments shall not be construed as the assumption of any obligation on the part of District or as creating any contractual relationship between District and any Subcontractor or Sub-subcontractor and shall not relieve Contractor of any of its obligations under the Contract Documents.

#### **9.4 CERTIFICATE FOR PAYMENT**

9.4.1 If Contractor has made an Application For Payment in accordance with Article 9.3, the Construction Manager will, not later than seven (7) Days after the date of receipt of an Application For Payment prepared and submitted in accordance with the Contract Documents, issue to District, with copy to Contractor, a Certificate For Payment in such amount as the Construction Manager determines is due.

If Construction Manager determines that Contractor's Application For Payment

has not been properly prepared or submitted, then Construction Manager, within the seven (7) Day period provided for in Article 9.4.1, notify Contractor in writing of the reasons why the Application for Payment is being rejected.

9.4.2 Approval of all or any part of an Application For Payment may be withheld, a Certificate For Payment may be withheld or all or part of a previous Certificate For Payment may be nullified and that amount withheld from a current Certificate For Payment in order to protect District against actual or threatened loss as a result of any of the following:

- (i) Defective Work not remedied.
- (ii) Third-party claims against Contractor or District arising from the acts or omissions of Contractor, Subcontractors, or Sub-subcontractor, of any Tier.
- (iii) Stop notices.
- (iv) Failure of Contractor to make timely payments due Subcontractors for material or labor.
- (v) A reasonable doubt that the Work can be completed for the balance of the Contract Sum then unpaid.
- (vi) Damage to District or Separate Contractor for which Contractor is responsible.
- (vii) Reasonable evidence that the Work will not be completed within the Contract Time.
- (viii) Failure of Contractor to maintain and update As-Built or Record Documents.
- (ix) Failure of Contractor to submit schedules, reports, or their updates as required by the Contract Documents.
- (x) Performance of Work by Contractor without approved Submittals.
- (xi) Liquidated or actual damages assessed in accordance with the Construction Contract.
- (xii) Any other failure of Contractor to perform an obligation under the Contract Documents.

9.4.3 Subject to the withholding provisions of Article 9.4.2 and when any or all of the noted deficiencies or others have been removed, District shall pay Contractor the amount set forth in the Certificate For Payment in accordance

(v) General Conditions

with its normal disbursement procedures.

9.4.4 Neither District nor the Construction Manager shall have an obligation to pay or to see to the payment of money to a Subcontractor or Sub-subcontractors, of any Tier, except as may otherwise be required by Law.

9.4.5 Neither a Certificate For Payment nor any payment (progress or final) shall be construed as a waiver of any rights arising from Defective Work.

## **9.5 DEPOSIT OF SECURITIES IN LIEU OF RETENTION AND DEPOSIT OF RETENTION INTO ESCROW**

9.5.1 At the request and expense of Contractor, a substitution of securities may be made as found in the California Government Code, Section 16430, and as authorized by the California Public Contract Code, Section 22300, in lieu of monies retained by District under Article 9.2 to ensure performance under the Contract Documents. Securities equivalent in value to the retention amount required by the Contract Documents for each Certificate For Payment shall be deposited by Contractor with a state or federally chartered bank in the State of California ("Escrow Agent"), which shall hold such securities pursuant to the escrow agreement referred to in Article 9.5.3 until final payment is due in accordance with Article 9.8. Securities shall be valued as often as conditions of the securities market warrant, but in no case less than once per month. Contractor shall deposit additional securities so that the current market value of the total of all deposited securities shall be at least equal to the total required amount of retention.

9.5.2 Alternatively to Article 9.5.1, and at the request and expense of Contractor, District shall deposit retention directly with the Escrow Agent. Contractor may direct the investment of such deposited retention into interest bearing accounts or securities, and such deposits or securities shall be held by the Escrow Agent upon the same terms provided for securities deposited by Contractor.

9.5.3 A prerequisite to the substitution of securities in lieu of retention or the deposit of retention into escrow shall be the execution by Contractor, District, and the Escrow Agent of an Escrow Contract for Deposit of Securities in Lieu of Retention and Deposit of Retention forms provided by District. The terms of such escrow agreement are incorporated into the requirements of Article 9.5.

9.5.4 Release of funds or securities from escrow shall be made with Contractor's final payment.

## **9.6 BENEFICIAL OCCUPANCY / BENEFICIAL USE**

9.6.1 District reserves the right, at its option and convenience, to occupy or

otherwise make use of all or any part of the Work, at any time prior to issuing the Certificate of Substantial Completion, upon thirty (30) Days' notice to Contractor. Such occupancy or use is herein referred to as "Beneficial Occupancy/Use." Beneficial Occupancy/Use shall be subject to the following conditions:

.1 District, Design Consultant and Construction Manager will make an inspection of the portion of the Work to be beneficially occupied and prepare a list of items to be completed or corrected prior to Substantial Completion.

.2 Beneficial Occupancy/Use by District shall not be construed by Contractor as Acceptance by District of that portion of the Work which is to be occupied. District may, however, at its sole option, relieve Contractor of Contract requirements to protect Work being beneficially occupied by District where such relief is specifically designated by District in writing.

.3 Beneficial Occupancy/Use by District shall not constitute a waiver of existing Claims of District or Contractor against each other.

.4 Contractor shall provide, in the areas beneficially occupied and on a continual basis (if required), utility services, heating, and cooling for systems which are in operable condition at the time of Beneficial Occupancy/Use. All responsibility for the operation and maintenance of equipment shall remain with Contractor while the equipment is so operated. Contractor shall submit to District an itemized list of each piece of equipment so operated with the date operation commences.

.5 The Guarantee to Repair Periods, as defined in Article 12.2, will commence upon the first dates of actual occupancy or use of portions of the Work actually occupied and equipment or systems fully utilized.

.6 District shall pay all normal operating and maintenance costs resulting from its use of equipment in areas beneficially occupied.

.7 District shall pay all utility costs which arise out of the Beneficial Occupancy/Use.

.8 Contractor shall not be responsible for providing security in areas beneficially occupied or used.

.9 District shall use its best efforts to prevent its Beneficial Occupancy/Use from interfering with the conduct of Contractor's remaining Work.

.10 Contractor shall not be required to repair damage caused by District in its Beneficial Occupancy/Use.

.11 Except as provided in Article 9.6, there shall be no added cost to District due to Beneficial Occupancy/Use.



.12 Contractor shall continue to maintain all insurance required by the Contract in full force and effect.

## **9.7 SUBSTANTIAL COMPLETION**

9.7.1 When Contractor gives notice to District that the Work, or portion thereof designated by District for separate delivery, is Substantially Complete, unless District determines that the Work or designated portion thereof is not sufficiently complete to warrant an inspection to determine Substantial Completion, District will inspect the Work, or such designated portion thereof, and prepare and give to Contractor a comprehensive list of items, if any, to be completed or corrected before establishing Substantial Completion. Contractor shall promptly proceed to complete and correct items on the list. Failure to include an item on such list does not alter the responsibility of Contractor to complete all Work in accordance with the Contract Documents. District will then make a further inspection to determine whether the Work or such designated portion thereof is Substantially Complete. If District's inspection discloses any item, whether or not included on the list, which must be completed or corrected before Substantial Completion, Contractor shall, before issuance of the Certificate of Substantial Completion, complete or correct such item. Contractor shall then submit a request for another inspection by District to determine Substantial Completion.

9.7.2 When District determines that the Work or such designated portion thereof is Substantially Complete, District will prepare a Certificate of Substantial Completion on District's form, which when signed by District shall establish the date of Substantial Completion and the responsibilities of District and Contractor for security, maintenance, heat, utilities, insurance, completion of minor items and correction or repair of the Work or such designated portion thereof. Unless otherwise provided in the Certificate of Substantial Completion, the Guarantee To Repair Period for the Work (which is defined in Article 12.2.1), or such designated portion thereof covered by the Certificate of Substantial Completion, excluding any systems provided by Separate Contractors which are not yet fully operational or accepted by District, shall commence on the date of Substantial Completion of the Work or such designated portion thereof. The Guarantee To Repair Period for systems which become fully operational or Accepted subsequent to Substantial Completion will begin on the later of the date they are operational or Acceptance of the Project by District.

## **9.8 FINAL COMPLETION AND FINAL PAYMENT**

9.8.1 Upon receipt of notice from Contractor that the Work is ready for final inspection, District will make such inspection. District will file a notice of completion within ten (10) Days after Acceptance by District. After receipt of the Final Application for Payment, if District determines that Final Completion is achieved, District will issue a Certificate for final payment.

9.8.2 Without limitation to any other provisions of the Contract Documents, before final payment for Work under this Construction Contract is authorized, the Work has been completed in accordance with the Contract Documents and all applicable standards of care and the following requirements of the Contract Documents must be fulfilled by Contractor:

- (i) The submittal of an Application for Final Payment, together with supporting documentation, as required by Article 9.3.
- (ii) Completion and delivery by Contractor to District of all required written guarantees, warranties, operation and maintenance manuals, As-Built Documents and other Record Documents and such other documents as required by the Contract Documents.
- (iii) Delivery by Contractor to District of an affidavit, signed under penalty of perjury, stating that all workers and persons employed, all firms supplying the materials, and all Subcontractors and Sub-subcontractors, of every Tier, have been paid in full; and that there are no bills outstanding against the Work for either labor or materials, except certain items, to be set forth in such affidavit covering disputed claims or items in connection with which notices to withhold have been filed under the provisions of the statutes of the State of California.
- (iv) Completion of all construction work in a manner acceptable to District.
- (v) Submission of conditional releases of claims and stop notices upon final payment from Contractor and its Subcontractors and Sub-subcontractors, of every Tier, with no reservation of rights for disputed claims or amounts. Contractor shall pay or cause to be paid to Subcontractors and Sub-Subcontractors, of every Tier, the amount stated in the conditional releases within five (5) Days after receipt of the final payment and shall promptly thereafter furnish evidence of such payment to District.

9.8.3 Acceptance of final payment by Contractor shall constitute a waiver of all Claims, except those previously made in writing and identified by Contractor as unsettled at the time of the Application for Final Payment.

9.8.4 District shall have the right, in its sole discretion, to make payment of amounts retained from progress payments on the Work of any Subcontractor at any time prior to Final Completion. The making of such early payment of retention shall not be construed as creating any obligation on the part of District nor shall it relieve Contractor of any of its obligations under the Contract Documents.

## **ARTICLE 10 – PROTECTION OF PERSONS AND PROPERTY**

### **10.1 SAFETY PRECAUTIONS AND PROGRAMS**

10.1.1 Contractor shall be solely and completely responsible for initiating, maintaining and supervising all safety precautions and programs on the Site in connection with the performance of the Construction Contract, including safety of all persons for the duration of the Work, on a 24-hour day, 7-day week basis.

10.1.2 Prior to the start of construction, Contractor shall submit to District a copy of Contractor's safety program for the Project. A copy of this program shall be maintained on Site at all times. The safety program shall include, at a minimum:

- (i) Management policy, illness and injury prevention program (as described below).
- (ii) Safety meetings.
- (iii) Accident investigation.
- (iv) Basic accident causes.
- (v) Safety inspection check list.
- (vi) Fire prevention and control.
- (vii) Report forms.
- (viii) Employee safety manual.

10.1.3 Prior to the start of construction, Contractor shall submit to District a copy of an illness and injury prevention program as required by law. This program must be submitted prior to issuance by District of Notice to Proceed. It must include provisions for Contractor reviewing and monitoring all Subcontractor safety programs.

### **10.2 SAFETY OF PERSONS AND PROPERTY**

10.2.1 Precaution shall be exercised at all times for the protection of persons and property. Contractor shall have available at the Site, copies, or suitable extracts of "Construction Safety Orders" and "General Industrial Safety Orders" issued by the State Division of Industrial Safety. Contractor shall comply with provisions of these and all other applicable laws, ordinances, and regulations.

10.2.2 Contractor shall immediately respond to notice from District of unsafe conditions, shall take adequate precautions for safety of persons on the Site, and

(v) General Conditions

shall provide adequate protection to prevent injury or Loss to the following:

- (i) Employees involved in the Work and other persons who may be affected thereby.
- (ii) The Work in place and materials and equipment to be incorporated therein, whether in storage on or off the Site, under care, custody, or control of Contractor, Subcontractors, or Sub-subcontractors.
- (iii) Other property at the Site and adjoining property(ies).

10.2.3 Contractor shall promptly remedy damage and Loss (other than damage or Loss insured under property insurance required by the Contract Documents) to property caused in whole or in part by Contractor or its Subcontractors or Sub-subcontractors, of any Tier, or anyone for whose acts they may be liable and for which Contractor is responsible. An exception is Loss attributable to acts of the Construction Manager, District or Design Consultant or anyone directly or indirectly employed by either of them, or by anyone for whose acts either of them may be liable, and not attributable to the fault or negligence of Contractor or its Subcontractors or Sub-subcontractors, of any Tier.

10.2.4 Contractor shall erect and maintain, as required by existing conditions and performance of the Work, adequate safeguards for safety and protection, including providing adequate lighting and ventilation, posting danger signs and other warnings against hazards, promulgating safety regulations, and notifying owners and users of adjacent sites and utilities.

10.2.5 When use or storage of hazardous materials, equipment, or unusual methods are necessary for execution of the Work, Contractor shall exercise the utmost care and carry on such activities only under the supervision of properly qualified personnel.

10.2.6 Contractor shall be required to provide at the Site a member of Contractor's organization, typically the Superintendent, whose responsibility it shall be to provide instruction to persons present on the Site about prevention of accidents and overall jobsite safety. If Contractor has another individual responsible for these activities, Contractor shall notify District in writing.

10.2.7 Contractor shall be responsible for locating, providing, and coordinating the storage and staging of materials and equipment on-Site and off-Site and shall not load/store or permit any part of the Work on the Site to be loaded/stored so as to endanger the safety of persons or property.

10.2.8 Contractor shall protect its materials and the Work from damage in a manner satisfactory to District and shall make good, without charge to District, all damage due to negligence in providing proper protection.

(v) General Conditions

10.2.9 Contractor shall take necessary precautions to guard against and eliminate possible fire hazards and to prevent damage to the Work, building materials, equipment, temporary field offices, storage sheds and public and private property.

10.2.10 Contractor shall not permit the possession or use of alcohol or controlled substances on the Site.

10.2.11 Explosives may be used only when authorized in writing by District. Explosives shall be handled, used, and stored in accordance with applicable regulations.

### **10.3 EMERGENCIES**

10.3.1 In an emergency affecting the safety of persons or property, Contractor shall immediately act to prevent or minimize damage, injury, or loss. Contractor shall immediately notify the Construction Manager and District, which notice may be oral, followed within twenty-four (24) hours after occurrence of the incident by written confirmation, of the occurrence of such an emergency and Contractor's action.

---

## **ARTICLE 11 – INSURANCE AND BONDS**

### **11.1 CONTRACTOR'S INSURANCE**

11.1.1 Prior to commencing the Work, Contractor shall procure and maintain at Contractor's own cost and expense, insurance as required in the Construction Contract between Contractor and District against claims for injuries to persons or damages to property which may arise out of or result from the performance of the Work by Contractor, its Subcontractors or Sub-subcontractors, by anyone directly or indirectly employed by any of them, or by anyone for whose acts any of them may be liable.

### **11.2 BOND REQUIREMENTS**

11.2.1 Within ten (10) Days after the issuance of the Notice of Award and prior to commencing Work on the Project, Contractor shall file with District good and sufficient Labor and Material Payment and Performance Bonds each in the amount of 100% of the Contract Sum. The bonds shall be signed by both Contractor and Surety and properly notarized on the District's forms or such other forms as required by District. Should any bond required hereunder or any surety on such bond become or be determined by District to be insufficient, it shall be replaced within ten (10) Days by a bond that fully complies with the requirements of Article 11.2. No further payments to Contractor for Work performed shall be made or due until Contractor has fully complied with the requirements of Article 11.2.

11.2.2 The Payment Bond shall remain in effect until Acceptance of the Work and payment of all Claims by Contractor, Subcontractors, or Sub-subcontractors, of any Tier, have been satisfied. The Performance Bond provided by Contractor shall remain in effect for the duration of the period of all warranties required by the Contract Documents and shall assure faithful performance of all Contractor's obligations under the Contract Documents, including, without limitation, all obligations that survive Final Completion or termination, such as, but not limited to. Contractor's warranty and indemnity obligations.

11.2.3 Contractor shall promptly furnish such additional security as may be required by District to protect its interests and those interests of persons or firms supplying labor or materials to the Work.

11.2.4 Surety companies used by Contractor shall be, on the date the Contract is signed by District and at all times while the bonds are in effect, either California Admitted Sureties or listed in the latest published United States Treasury Department list of Companies Holding Certificates of Authority as Acceptable Sureties on Federal Bonds and as Acceptable Reinsuring Companies and either have a current A.M. Best A VIII rating or be an admitted surety that meets the requirements of the California Code of Civil Procedure, Section 995.660.

11.2.5 The premiums for all Bonds are included in the Contract Sum and shall be paid by Contractor.

11.2.6 The bonds shall name District as obligee.

11.2.7 Change Orders, Field Orders, Modifications, Changes in the Work and adjustments in the scope of Work Contract Sum or Contract Time shall in no way release or exonerate Contractor or its sureties from their obligations and notice thereof shall be waived by such sureties.

11.2.8 District and the Construction Manager shall have the right to communicate with Contractor's sureties with respect to matters that are related to Contractor's performance of its obligations under the Contract Documents. Contractor shall be provided with a copy of all such written communications. Such communications shall not create or be interpreted as creating any contractual relationship between District or the Construction Manager and any such surety.

11.2.9 In the event of a significant (15% or more) increase in Contract Sum, replacement bonds totaling the new Construction Contract amount may be required by District.

---

## **ARTICLE 12 – DEFECTIVE WORK**

### **12.1 UNCOVERING OF WORK**

12.1.1 If a portion of the Work is covered contrary to District's request or direction, or contrary to the requirements of the Contract Documents, it must, if required in writing by District, be uncovered for District's observation and be replaced at Contractor's expense without adjustment of the Contract Time or the Contract Sum.

12.1.2 If a portion of the Work has been covered, which is not required by the Contract Documents to be observed or inspected prior to its being covered and which District has not specifically requested to observe prior to its being covered, District may request to see such Work and it shall be uncovered and replaced by Contractor. If such Work is in accordance with the Contract Documents, the costs of uncovering and replacing the Work shall be added to the Contract Sum by Change Order; and if the uncovering and replacing of the Work extends the Contract Time, an appropriate adjustment of the Contract Time shall be made by Change Order. If such Work is not in accordance with the Contract Documents, Contractor shall pay such costs and shall not be entitled to an adjustment of the Contract Time or the Contract Sum.

### **12.2 CORRECTION OF DEFECTIVE WORK AND GUARANTEE TO REPAIR PERIOD**

12.2.1 Besides guarantees required elsewhere, Contractor shall guarantee in writing all Work for a period of one (1) year. This guarantee termed "Guarantee To Repair Period," is a period of one (1) year, unless a longer period of time is specified in the Special Provisions and Technical Specifications, commencing as follows:

- (i) For any Work not described as incomplete in the Certificate of Substantial Completion, on the date of Substantial Completion.
- (ii) For space beneficially occupied or for separate systems fully utilized prior to Substantial Completion pursuant to Article 9.6, from the first date of such Beneficial Occupancy or actual use, as established an appropriate written authorization for Beneficial Occupancy.
- (iii) For all Work other than (i) or (ii) above, from the date of filing of notice of completion pursuant to Article 9.8.

12.2.2 Contractor shall (i) correct Defective Work that becomes apparent during the progress of the Work or during the Guarantee To Repair Period and (ii) replace, repair, or restore to District's satisfaction any other parts of the Work and any other real or personal property which is damaged or destroyed as a result of Defective Work or the correction of Defective Work, without any expense

(v) General Conditions



whatsoever to District. District will give notice of observed Defective Work with reasonable promptness, and Contractor shall promptly commence such correction, replacement, repair, or restoration upon notice from District, but in no case later than seven (7) Days after receipt of such notice. Contractor shall diligently and continuously prosecute such correction to completion. Contractor shall bear all costs of such correction, replacement, repair, or restoration and all Losses resulting from such Defective Work, including additional testing, inspection and compensation for District's or District's services and expenses. Contractor shall perform corrective Work at such times that are acceptable to District and in such a manner as to avoid, to the extent practicable, disruption to District's activities. Ordinary wear and tear, unusual abuse or neglect are excepted from this guarantee. Contractor shall notify District upon completion of repairs.

12.2.3 If immediate correction of Defective Work is required for life safety or the protection of property or, if in the opinion of District, Defective Work creates a dangerous condition or requires immediate corrections or attention to prevent further Loss to District or to prevent interruption of operations of District, District will attempt to give immediate notice to Contractor. If Contractor cannot be contacted or does not comply with District's request for correction within a reasonable time as determined by District, District or Separate Contractors under District's direction, may, notwithstanding the provisions of this Article, proceed to make such corrections or provide such attention; and the costs of such correction or attention shall be charged against Contractor. Such action by District will not relieve Contractor of the guarantees provided in this Article or elsewhere in the Construction Contract. Contractor shall replace, repair, or restore to District's satisfaction any other parts of the Work and any other real or personal property, which is damaged or destroyed as a result of such Defective Work or the correction of such Defective Work.

12.2.4 Contractor shall promptly remove from the Site those portions of the Work and materials which are not in accordance with the Contract Documents and which are neither corrected by Contractor nor accepted by District.

12.2.5 If Contractor fails to commence correction of Defective Work within seven (7) Days after notice from District or fails to diligently prosecute such correction to completion, District may correct the Defective Work in accordance with Article 2.4; and, in addition, District may remove the Defective Work and store salvageable materials and equipment at Contractor's expense.

12.2.6 If Contractor fails to pay the costs of such removal and storage as required by Articles 12.2.4 and 12.2.5 within seven (7) Days after written demand, District may, without prejudice to other remedies, sell such materials at auction or at private sale or otherwise dispose of such material. Contractor shall be entitled to the proceeds of such sale, if any, in excess of the costs and damages for which Contractor is liable to District, including compensation for District's services and expenses. If such proceeds of sale do not cover costs and

damages for which Contractor is liable to District, the Contract Sum shall be reduced by such deficiency. If there are no remaining payments due Contractor or the remaining payments are insufficient to cover such deficiency, Contractor shall promptly pay the difference to District.

12.2.7 Contractor's obligations under this Article are in addition to and not in limitation of its warranty under Article 3.5 or any other obligation of Contractor under the Contract Documents. Enforcement of Contractor's express warranties and guarantees to repair contained in the Contract Documents shall be in addition to and not in limitation of any other rights or remedies District may have under the Contract Documents or at law or in equity for Defective Work. Nothing contained in this Article shall be construed to establish a period of limitation with respect to other obligations of Contractor under the Contract Documents, which may be longer specified periods. Establishment of the Guarantee To Repair Period relates only to the specific obligation of Contractor to correct the Work and in no way limits either Contractor's liability for Defective Work or the time within which proceedings may be commenced to enforce Contractor's obligations under the Contract Documents.

### **12.3 ACCEPTANCE OF DEFECTIVE WORK**

12.3.1 Notwithstanding the provisions of Article 12.2 of these General Conditions, District shall have the option, at its sole discretion and by notice to Contractor, to accept Defective Work instead of requiring its removal or correction, in which case the Contract Sum shall be reduced by an amount equal to the difference between the value to District the Work would have had were it complete, correct and in conformity with the Contract Documents and the value to District of such Defective Work. Such option shall be exercised solely by notice to Contractor and shall not be implied from any act or omission by District or Construction Manager. If there are no remaining payments of the Contract Sum to be made to Contractor, or if the remaining payments and retention are insufficient to cover the amount of the reduction of the Contract Sum, Contractor shall promptly pay to District the amount of any such deficiency.

---

## **ARTICLE 13 – STATUTORY REQUIREMENTS**

### **13.1 NONDISCRIMINATION/EQUAL OPPORTUNITY**

13.1.1 For purposes of this Article, the term Subcontractor shall not include suppliers, manufacturers, or distributors, except those who will actually perform work on the Site.

13.1.2 Contractor shall comply and shall ensure that all Subcontractors comply with the California Government Code, Section 12900, and the applicable sections that follow.

13.1.3 Contractor agrees as follows during the performance of the Work:

.1 Contractor shall not discriminate against any employee or applicant for employment because of race, color, religion, sex, age, ancestry, national origin, sexual orientation, handicap, veteran's status, medical condition (as defined in the California Government Code, Section 12926), marital status, or citizenship. All applicants for employment and employees are to be treated without regard to their race, color, religion, sex, age, ancestry, national origin, sexual orientation, handicap, veteran's status, medical condition (as defined in the California Government Code, Section 12926), marital status, or citizenship. Such equal treatment shall apply, but not be limited to:

- (i) Employment, upgrading, demotion, or transfer.
- (ii) Recruitment or recruitment advertising.
- (iii) Layoff or termination.
- (iv) Rates of pay or other forms of compensation.
- (v) Selection for training, including apprenticeship.

.2 Contractor agrees to post in conspicuous places, available to employees and applicants for employment, the Notice of Equal Employment Opportunity (EEO) setting forth this provision.

.3 Contractor shall send to each labor union, with which it has a collective bargaining agreement or other contract or understanding, the letter of Concurrence and the Notice of Equal Employment Opportunity (EEO) advising them of Contractor's commitments under this provision; and Contractor shall post copies of the Notice of Equal Employment Opportunity (EEO) in conspicuous places available to employees and applicants for employment. The Notice of Equal Employment Opportunity (EEO) shall be in English and other applicable languages.

.4 Contractor and all Subcontractors will permit access to their records of employment, employment advertisements, application forms, and other pertinent data and records by District or any appropriate District of the State of California designated by District for the purposes of investigation to ascertain compliance with this provision. The outcome of the investigation may result in the following:

a. A finding of willful violation of the provisions of this Construction Contract or of the Fair Employment Practices Act may be regarded by District as either of the following:

(i) A basis for determining that Contractor is not a "responsible bidder" as to future contracts for which such Contractor may submit bids.

(ii) A basis for refusing to accept or consider the bids of Contractor for future contracts.

b. District may deem a finding of willful violation of the Fair Employment Practices Act to have occurred upon receipt of written notice from the Fair Employment Practices Commission that it has done both of the following:

(i) Investigated and determined that Contractor has violated the Fair Employment Practices Act.

(ii) Issued an order under the California Government Code, Section 12970, or obtained an injunction under the California Government Code Section 12973.

c. Upon receipt of such written notice from the Fair Employment Practices Commission, District may notify Contractor that, unless it demonstrates to the satisfaction of District within a stated period that the violation has been corrected, Contractor's bids on future projects will not be considered.

.5 Contractor agrees that, should District determine that Contractor has not complied with this provision, Contractor shall forfeit to District, as a penalty, for each day or portion thereof, for each person who was denied employment as a result of such non-compliance, the penalties provided in Article 13.3 for violation of prevailing wage rates. Such penalty amounts may be recovered from Contractor; and District may deduct any such penalty amounts from the Contract Sum.

.6 Nothing contained in this provision shall be construed in any manner so as to prevent District from pursuing any other remedies that may be available at law.

.7 Contractor shall meet the following standards for affirmative compliance and provide District with satisfactory evidence of such compliance upon District's request, which shall be evaluated in each case by District:

a. Contractor shall notify its Superintendent and other supervisory personnel of the nondiscrimination requirements of the Contract Documents and their responsibilities thereunder.

b. Contractor shall notify all sources of employee referrals (including unions, employment agencies, and the State of California Department of Employment) of the nondiscrimination requirements of the Contract Documents by sending to such sources and by posting the Notice of Equal Employment Opportunity (EEO).

c. Contractor or its representative shall, through all unions with whom it may have agreements, develop agreements that:

(i) Define responsibilities for nondiscrimination in hiring, referrals, upgrading, and training.

(ii) Implement an affirmative nondiscrimination program, in terms of the unions' specific areas of skill and geography, such that qualified minority women, non-minority women, and minority men shall be available and given an equal opportunity for employment.

d. Contractor shall notify District of opposition to the nondiscrimination requirements of the Contract Documents by individuals, firms, or organizations during the term of the Contract.

.8 Contractor shall include the provisions of the foregoing Articles 13.1.3.1 through 13.1.3.6 in all subcontracts with Subcontractors, so that such provisions will be binding upon each such Subcontractor.

## **13.2 STATE LABOR LAW**

13.2.1 Contractor, its agents, and employees shall be bound by and comply with all applicable provisions of the Labor Code and such federal, state and local laws which affect the conduct of the Work.

13.2.2 Contractor shall strictly adhere to the provisions of the Labor Code regarding the employment of apprentices; minimum wages; payment of wages; alien labor, the eight- hour day; overtime, Saturday, Sunday, and holiday work; registration with the Department of Industrial Relations to maintain eligibility to work on public works; and nondiscrimination because of race, color, national origin, age, marital status, sexual orientation, disability, sex or religion. Contractor shall forfeit to District the penalties prescribed in the Labor Code for violations.

13.2.3 District has ascertained that the general prevailing rate of wages and employer payments for health and welfare, vacation, pensions, and similar purposes applicable to the locality in which the Work is to be done are as set

(v) General Conditions

forth in that certain document entitled, "Prevailing Wage Scale," as indicated in the California Labor Code Part 7, Chapter 1 – Article 2, as determined by the Director of Industrial Relations. Applicable Prevailing Wage Rates and related information not listed are to be obtained from the State of California by Contractor. Contractor shall post a copy of applicable exhibits/wage rates at each Site. Contractor to whom the Construction Contract is awarded and any Subcontractor agree to pay wages and benefits not less than said specified rates to all workers employed by them in the execution of the Construction Contract. A person or concern who fails to do so shall be subject to withholding of contract payments equal to the underpayment of required wages and benefits and subject to the penalties provided for in the California Labor Code, Section 1775. Contractor and each Subcontractor shall prepare and certify their payrolls on forms satisfactory and in accordance with instructions to be furnished by District.

13.2.4 In accordance with the Labor Code, prevailing wage rate determinations for the work to be done on this Project are maintained by the District.

13.2.5 In the event there is a determination that Contractor is in violation of prevailing wage requirements, Contractor shall reimburse District for all investigative costs incurred in addition to any other remedies provided under the Contract Documents.

### **13.3 PAYROLL RECORDS**

13.3.1 Contractor and all Subcontractors shall keep an accurate payroll record, showing the name, address, social security number, job classification, straight time and overtime hours worked each day and week, and the actual per diem wages paid to each journey worker, apprentice worker, or other employee employed in connection with the Work. All payroll records shall be certified as being true and correct by Contractor or Subcontractors keeping such records; and the payroll records shall be available for inspection at all reasonable hours at the principal office of Contractor on the following basis:

.1 A certified copy of an employee's payroll record shall be made available for inspection or furnished to such employee or the employee's authorized representative upon request.

.2 A certified copy of all Contractor and Subcontractor payroll records shall be made available for inspection upon request to District, the State of California Division of Labor Standards Enforcement, and the Division of Apprenticeship Standards of the State of California Division of Industrial Relations. A certified copy of all payroll records shall be furnished to District or its representatives upon request.

.3 A certified copy of all payroll records shall be made available upon request by the public for inspection or copies thereof made; provided, however, that the

request by the public shall be made to either District, the Division of Apprenticeship Standards, or the Division of Labor Standards Enforcement. The public shall not be given access to such records at the principal offices of Contractor or Subcontractors. Any copy of the records made available for inspection as copies and furnished upon request to the public or any public entity by District shall be marked or obliterated in such a manner as to prevent disclosure of an individual's name, address, and social security number. The name and address of Contractor awarded the Construction Contract or performing the Construction Contract shall not be marked or obliterated.

.4 As of April 1, 2015: contractors and subcontractors must furnish electronic certified payroll records to the Labor Commissioner (State of California, Division of Labor Standards Enforcement).

13.3.2 Contractor and all Subcontractors shall file a certified copy of the payroll records with the entity that requested the records within ten (10) Days after receipt of a written request. Contractor shall inform District of the location of such payroll records for the Project, including the street address, District, and county; and Contractor shall, within ten (10) days, provide notice of change of location of such records. In the event of noncompliance with the requirements of Article 13.3 or with the California Labor Code Section 1776, Contractor and its Subcontractors shall have ten (10) Days in which to comply following receipt of a notice specifying in what respects Contractor must comply. Should non-compliance still be evident after the ten (10) Day period, Contractor shall forfeit to District, as a penalty, one hundred dollars (\$100.00) for each Day, or portion thereof, for each worker, until strict compliance is accomplished. Such forfeiture amounts may be deducted from the Contract Sum. Contractor shall include stipulations in all of its subcontracts to ensure that Subcontractors comply with Section 13.3.

## **13.4 APPRENTICES**

13.4.1 Attention is directed to the California Labor Code, Sections 1777.5, 1777.6, and 1777.7 and the California Code of Regulations, Title 8, Section 200, and the applicable sections that follow. To ensure compliance and complete understanding of the law requiring apprentices, and specifically the required ratio thereunder, Contractor or Subcontractors should, where some question exists, contact the State of California Division of Apprenticeship Standards prior to commencement of the Work. Responsibility for compliance with these requirements lies with Contractor

## **13.5 WORK DAY**

13.5.1 Contractor shall not permit any worker to labor more than eight (8) hours during any one (1) Day or more than forty (40) hours during any one (1) calendar week, except as permitted by law and in such cases only upon such conditions as are provided by law. Contractor shall forfeit to District, as a penalty, fifty dollars (\$50.00) for each worker employed in the execution of this Construction Contract

by Contractor, or any Subcontractor, for each Day during which such worker is required or permitted to Work more than eight (8) hours in any one (1) Day and forty (40) hours in any one (1) calendar week in violation of the terms of this provision or in violation of the provisions of any law of the State of California. Such forfeiture amounts may be deducted from the Contract Sum. Contractor and each Subcontractor shall keep, or cause to be kept, an accurate record showing the actual hours worked each Day and each calendar week by each worker employed on the Project, which record shall be kept open at all reasonable hours to the inspection of District, its officers and agents, and to the inspection of the appropriate enforcement agency or representative and the State of California.

**END OF GENERAL CONDITIONS**



**OCEANO COMMUNITY SERVICES DISTRICT**  
**WATER STORAGE TANK REHABILITATION**  
**SPECIAL PROVISIONS AND/OR TECHNICAL SPECIFICATIONS**  
**PLANS AND DRAWINGS**  
**FOR**  
**OCEANO, CA**  
**CONTRACT NO. 2023-03**

**See bid document:**

**Advantage Technical Services, Inc – Project Manual for Oceano Community Services District’s  
0.3 Million Gallon Water Tank Recoating and Roof Replacement Project**

**PROJECT MANUAL FOR**  
**OCEANO COMMUNITY SERVICE DISTRICT'S**  
**0.3 MILLION GALLON WATER TANK RECOATING AND**  
**ROOF REPLACEMENT PROJECT**



## PART I - NOTICE, PROPOSAL, AND AGREEMENT FORMS

### TABLE OF CONTENTS

#### Section

Notice to Contractors  
Notice Inviting Bids  
Instructions to Bidders

By others
-----------

#### Proposal Forms

Proposal  
Experience Qualifications  
Bid Schedule(s)  
Contractor's Licensing Statement  
List of Subcontractors  
List of Material or Equipment Suppliers  
Bid Security Forms  
Noncollusion Declaration  
Affirmative Action Program  
Worker's Compensation Insurance Certificate

#### Agreement and Bond Forms

Agreement  
Performance Bond  
Payment Bond

#### Contract Administration Forms

Notice of Award  
Notice to Proceed  
Change Order  
Work Directive Change  
Notice of Completion  
Consent of Surety – Retainage  
Consent of Surety - Final Payment  
Unconditional Waiver - Final Payment

**PART II - CONDITIONS OF THE CONTRACT**

General Conditions of the Contract

By others

Supplementary General Conditions

**PART III - TECHNICAL SPECIFICATIONS**

Section 01100	Scope and Control of the Work
Section 01205	Measurement and Payment
Section 09905	Protective Coatings
Section 13010	Upgrades to the Existing Tank
Section 13020	Replace Water Tank Roof

**PART IV - APPENDICES**

Appendix A	Coatings Heavy Metals Testing
Appendix B	Project Drawings
Appendix C	Dive Inspection Report – Existing Welded Tank
Appendix D	Project Location & Existing Conditions

# **PART I**

## **NOTICE, PROPOSAL AND AGREEMENT FORMS**

## **PART II**

# **CONDITIONS OF THE CONTRACT**

## **PART III**

# **TECHNICAL SPECIFICATIONS**

Technical Specifications for:

OCEANO COMMUNITY SERVICES DISTRICT  
1655 Front St.  
Oceano, CA 93445

Prepared by:

ADVANTAGE TECHNICAL SERVICES, INC.  
6661 Fern Canyon Road  
San Luis Obispo, CA 93401  
805-595-2282

May 2023

### CERTIFICATION

In accordance with the provisions of Section 6735 of the Business and Professions Code of the State of California, these specifications have been prepared by or under the direction of the following Professional Engineers licensed in the State of California:



---

William D. Bellis, PE  
55334, Exp. 12/31/2024



Approved by:



---

Will Clemens  
District Manager



Section 01100

## SCOPE AND CONTROL OF THE WORK

### PART 1 - GENERAL

#### 1.01 SCOPE

The project generally includes upgrading appurtenances, replacing roof and roof structure and recoating the interior and exterior of one 0.3 million-gallon (approximately 40' diameter x 32' tall) welded water tank and other items specified herein and as shown on the Contract Documents. The following sections further define the scope of the Work as detailed within these specifications (planning and the actual order of work is the responsibility of the Contractor):

- A. The Contractor will provide any required sampling and testing of existing coatings. Coatings are known to contain lead and other heavy metals. Employee protections for disturbance of coatings containing lead and other heavy metals shall be included in all project planning and execution.
- B. The Contractor will complete engineering and planning and will provide submittals pursuant to these specifications.
- C. The Contractor will fabricate and shop coat replacement roof and appurtenances as specified.
- D. The District will provide access. The District provided work area is limited to the fenced unpaved tank site.
- E. The District will provide any applicable building permits.
- F. The Contractor will notify the District at least two weeks in advance of the start of demolition to allow the draw-down and use of the water in the existing tank.
- G. The District will draw-down the water in the existing tank and remove from service. The District will notify the Contractor when the tank has been removed from service and rehabilitation may be started. Some water and sediment will remain in the tank.
- H. The Contractor will remove the remaining water from the tank to allow for magnetic flux leakage (MFL) inspection of the bottom.
- I. If desired, the District will hire an MFL contractor and coordinate with the Contractor for up to five days for MFL inspection as the first order of work.
- J. The Contractor will provide safe access for the MFL inspection.
- K. The Contractor will mobilize to the site and will complete the specified work items including but not limited to demolition of tank roof, removal of CP system, repairs, new roof and structure, upgrades, preparation and coating on the tank.
- L. The Contractor will recycle steel that is removed as part of the replacement of the existing roof and other work.

- M. The Contractor will modify the existing compression ring as required for fit and drainage and provide a new roof and structure from the existing shell down to and including new base plates.
- N. The Contractor will prepare and install new exterior coatings including existing piping to 6" below grade.
- O. The Contractor will prepare interior, including removal of all interior coatings and install new interior coatings.
- P. The Contractor will provide containment of dust, mists and other transient materials during the work including but not limited to preparation and coating.
- Q. The interior coatings of the tank will be allowed to cure as recommended by the coating manufacturer.
- R. The Contractor will provide disinfection of interior surfaces as specified and seal the tank.
- S. The District will fill the newly painted tank and provide VOC and bacteriological testing and put the newly painted tank into service as appropriate. The Contractor will be held responsible for the cost of the water if the VOC testing results do not meet State standards.
- T. The Contractor will sample, test, provide transport and recycle spent abrasive.
- U. The Contractor will sample, test, provide transport and dispose of any coatings or materials not included with the spent abrasive.
- V. The Contractor will demobilize all construction equipment, construction materials, stabilize the site and return control of the site to the District.
- W. The Contractor will provide a one year warranty on the Work pursuant to these specifications.

#### 1.02 RELATED WORK SPECIFIED ELSEWHERE

- A. Section 01205, Measurement and Payment
- B. Section 09905, Protective Coatings
- C. Section 13020, Replace Water Tank Roof
- D. Section 13010, Tank Upgrades

#### 1.03 SUBMITTALS

- A. Submittals shall be provided in accordance with these Special Provisions. Submittals shall be provided electronically in "PDF" format. The Contractor shall maintain a full set of approved submittals on the job site.

The Contractor shall provide submittals before the pre-job conference. No work shall be done on items needing submittal approval until the material or plan is approved by the Owner.

Submittals shall be submitted to:

**Advantage Technical Services, Inc.**

Wbellis.ats@gmail.com

Attn: William D. Bellis, P.E.

Consulting Engineer

- B. The Contractor shall provide a Project Safety Plan prepared under the direction of and certified by a Certified Safety Professional (CSP) or other qualified independent consultant. The intent of the plan is to develop and document measures, appropriate to the Contractor's means and methods, which assure employee safety and regulatory compliance. The plan shall be submitted before the pre-construction conference. A copy of the Project Safety Plan shall be on site during the course of the project. Payment for providing and implementing the Safety Plan shall be considered as included in the various contract prices paid and no additional compensation will be allowed.

1.04 HEALTH, SAFETY AND ENVIRONMENTAL CONTROLS

- A. The project goals are to complete the work with no injuries, spills or other environmental incidents. The Contractor shall be responsible for conducting the work in a manner that protects project personnel, the public and the environment. The Contractor shall provide qualified persons and implement appropriate programs to control all aspects of the work including worker and public health, safety and environmental protection.
- B. The Contractor shall conduct regular safety meetings with continuous review potential hazards associated with the project. Steps shall be taken to mitigate hazards and maintain a safe workplace. Known project safety and environmental hazards include the following:
1. Falls
  2. Confined spaces
  3. Eye injury including arc burn
  4. Venomous snakes including rattle snakes
  5. Poisonous spiders including black widow and brown recluse
  6. Wild fire associated with grinding, welding and other equipment or ignition sources
  7. Fire or explosion associated with flammable fuels or solvents
  8. Vehicle accidents
  9. Spills from leaking equipment or storage containers
  10. Introduction of non-native species
  11. Work on and around existing lead based paints
  12. Work around paints including volatile organic compounds

1.05 NOISE

- A. Noise generated from equipment operating overnight including generators, pumps and dehumidification shall not exceed 75 dB at all property lines.
- B. Construction activities shall be restricted to the hours of 7:00AM to 5:00PM Monday through Friday. No construction shall occur on Saturday or Sunday. On-site equipment maintenance and servicing shall be confined to the same hours.
- C. All construction equipment utilizing internal combustion engines shall be required to have mufflers that are in good condition and tuned according to the manufacture's recommendations. Stationary noise sources shall utilize noise reducing engine housing enclosures or noise screens.

1.06 OSHA COMPLIANCE.

- A. Contractor shall comply with all applicable regulations including state and federal OSHA and these Special Provisions.
- B. Contractor is responsible for complying with Cal/OSHA regulations for lead in construction in accordance with California Code of Regulations, California Title 8, Section 1532.1.
- C. The costs for complying with all OSHA requirements shall be considered as included in the various contract prices paid and no additional compensation will be allowed. Contractors are encouraged to take lead samples in advance by arrangement with the owner.

1.07 LEAD

- A. The facilities included in this project were constructed after 1978. Cal/OSHA requires compliance with California Title 8, Section 1532.1 if the paint contains lead at any level. Interior and exterior coatings are known to contain lead and other heavy metals.
- B. The Owner assumes no responsibility for sampling or test results. Preliminary testing is included in the appendices of this document but they are for information only. All work involving the removal of lead containing coatings and the disposal of such removed material shall be in strict accordance with all applicable Local, State and Federal regulations and guidelines including notification, removal and containment techniques, proper transportation and disposal, and worker protection and monitoring.
- C. The Contractor is responsible to test the composite waste from the project to determine proper disposal. A copy of all test results shall be furnished to the Owner.
- D. For waste requiring the preparation of a hazardous waste manifest and waste shipment record, the Contractor shall prepare an accurate hazardous waste manifest and waste shipment record for signing by the Engineer. Neither the Contractor nor his employees shall sign the waste manifests or waste shipment records as the generator's representative. The Contractor shall provide the Owner with a certified weight ticket for each shipment of hazardous waste. If any waste is shipped to a disposal facility outside of California, the transporter and disposal facility shall complete and sign and distribute California's Hazardous Waste Manifest in the same manner as required by California law for the disposal facilities inside California.

- E. The Contractor will be responsible for any cleanup of areas where materials containing lead, heavy metals or other hazardous and non-hazardous materials have been released during the job. The Contractor shall assume all costs for such cleaning.

1.08 TEMPORARY FACILITIES.

- A. Power. The Contractor shall provide, at no additional cost to the Owner, all construction power used at the project sites.
- B. Sanitary Facilities. The Contractor shall make arrangements and provide for adequate portable toilet facilities at the site of work. The Contractor shall maintain the sanitary facilities in acceptable condition from the beginning of work until completion and shall remove the facilities and disinfect the premises.
- C. Water. The District will provide construction water used at the project site.

1.09 CONSTRUCTION DETAILS.

- A. The tank is located in Oceano, CA. The facilities serve a predominantly residential community.
- B. Tank Draining. Prior to the start of construction, Owner staff shall empty the Tank. The tank will be out of service and drained but some water will remain. The Contractor shall remove the remaining water as needed to facilitate the start of work.

1.010 ISOLATION OF EQUIPMENT

- A. The piping and equipment adjacent to the tank will be in service during the work. The Contractor shall work with plant operations personnel to assure safe working conditions and prevent damage to property and equipment.
- B. The Owner shall be responsible for lockout/tag out of all power on equipment. The Contractor shall confirm lockout/tag out before proceeding with work.

**PART 2 - PRODUCTS  
NOT APPLICABLE**

**PART 3 - EXECUTION**

3.01 HOUSEKEEPING AND CLEANUP

- A. At the end of each work day, dust and abrasive shall be removed from the surfaces and surrounding areas. Spent abrasive shall be stored in temporary storage containers on site pursuant to Best Management Practices and Best Pollution Prevention Practices listed under federal and state guidelines.
- B. The site shall be maintained free of unnecessary accumulations of tools, equipment, surplus materials, and debris. Equipment maintenance and spill prevention procedures shall be adequate to prevent spills and leaks.

- C. Upon completion of the work, the Contractor shall remove all excess materials, equipment, containers, and waste from the job site. Coating spots or stains shall be removed from adjacent surfaces and surfaces repaired if needed. As work proceeds, promptly remove all coating that is spilled, splashed, or splattered. Collect empty containers, rags, waste material, and debris and store or remove from the site as appropriate.

### 3.02 ACCESS, CONTAINMENT AND PROTECTION

- A. The Contractor shall provide scaffolding or other access and fall protection anchors to allow safe access for Contractor personnel, inspection personnel and others as appropriate
- B. The tank is situated near residences. Creeks and all surface drains and swales lead directly onto the adjacent land, or to creeks and the ocean. Contractor shall protect all work sites and all drainage inlets from pollutants and illegal discharges.
- C. The work will be conducted in and around operational equipment and adjacent to residences. The Contractor shall provide containment or mitigation of air-borne dust, overspray and other contaminants to protect the existing equipment, facilities and neighboring properties from dust, overspray pursuant to regulatory requirements.

END OF SECTION

Section 01205

## MEASUREMENT AND PAYMENT

### PART 1 - GENERAL

This Section describes the methods of measurement and payment for the specific bid items associated with Work on the existing welded steel water tank. All other provisions of the Contract Documents which relate to measurement and payment are applicable, except that where conflicts occur between this section and other provisions of the technical specifications or reference specifications, this measurement and payment section shall prevail.

### PART 2 - PRODUCTS NOT APPLICABLE

### PART 3 - EXECUTION

#### 3.01 METHOD OF PAYMENT

- A.** Payment will be made on the basis of the unit prices or lump sums bid for the various items as called for on the Bid Sheet(s) and included in the Contract as awarded. The quantities given in the Proposal and Contract forms are approximate only and are given as a basis for the comparison of bids, and the Owner does not expressly or by implication agree that the actual amount of work will correspond therewith, but reserves the right to increase or decrease the amount of or any class or portion of the Work or to omit portions of the Work as may be deemed necessary or advisable by the Engineer.

#### 3.02 MEASUREMENT OF QUANTITIES

- A.** Materials paid for by the ton shall be weighed on public scales or other scales for which the State Bureau of Weights and Measures has issued a certificate of inspection which is available to the Engineer.
- B.** Full compensation for all expenses involved in conforming to the above requirements for weighing materials shall be included in the prices for the materials being weighed, and no additional allowance will be made therefore.
- C.** The quantity of materials paid for by the lineal foot, square foot or square yard shall be determined by horizontal measurement.

#### 3.03 SCOPE OF PAYMENT

- A.** The Contractor shall accept the compensation as herein provided as full payment for furnishing all materials, labor, tools, and equipment necessary to complete the Work, and for performing all work contemplated and embraced under the Contract; also, for loss or damage arising from the nature of the Work, or from the action of the elements, except as

heretofore provided, or from any unforeseen difficulties which may be encountered during the prosecution of the Work, until the final acceptance by the District, and for all risks of every description connected with the prosecution of the Work; also, for all expenses incurred in consequence of the suspension or discontinuance of the Work as herein specified; and for completing the Work according to the Plans and Specifications. Neither the payment of any estimate nor of any retained percentage shall relieve the Contractor of any obligation to make good any defective work or materials.

### 3.04 BID ITEMS

#### **A. Mobilization and Construction Coordination**

##### 1. Description

This work includes the furnishing of all tools, equipment, labor and materials required to accomplish all of the following Work within the limits designated on the plans or as directed by the Engineer in accordance with the plans and specifications. The Work includes but is not limited to the following:

- a. The Contractor shall develop a construction plan for the Work with means and methods that allow completion of the work pursuant to these specifications using the District's limited space of the fenced tank site for the Work or shall, independently from the District, acquire any temporary easements from landowners that are necessary for stockpile of materials, or facilitation of completion of the Work. The construction plan shall include all work for both tanks.
- b. Planning, coordination (2 week notice) and access to allow access and up to 5 normal working days for District testing lab consultant to complete magnetic flux leakage (MFL) bottom scan and ultrasonic testing of the existing bottom plate.
- c. Portable restroom(s) shall be on site prior to, or at the time of, the start of mobilization and shall remain on site during all on-site Work.
- d. Mobilization – Contractor shall move in and set up all equipment, provision for power, materials, etc. as necessary to complete all aspects of this project. This item also includes the cost of all bonds, insurance, and Permits for the Project.
- e. Easements – The Contractor may determine the location, type, extent and value to the Contractor of any temporary easement(s), which may facilitate completion of the Work, which is beyond the District's access easement and fenced tank site shown in the Plans and Specifications.
- f. Construction Schedule – The Contractor is responsible for preparing, amending, implementing, and complying with a construction schedule for all Work on this project. The initial schedule shall be submitted to the Engineer at the time of the award of the contract. The schedule shall be amended, and submitted to the Engineer, as necessary if progress varies significantly from the schedule and at a minimum, every month.
- g. Construction Water – The District will provide access to construction water.



- h. Submittals – The Contractor shall provide the submittals and associated planning and engineering including, field verification, structural calculations, shop drawings, materials data sheets, MSDS, certificates of compliance and other submittals required by the Work and these specifications.
- i. Utility Coordination – The Contractor is responsible for all coordination effort with regards to utilities on the project including temporary service interruptions, tie-ins, etc. and scheduling the inspection of all Contractor Work. The Contractor shall be responsible for any financial claims associated with missed inspections, repeat inspections, or any costs associated with re-working portions of the project due to failed inspections or lack of inspections based on the Contractors failure to schedule and follow through with same.
- j. Project Controls- A Health and Safety Plan for worker protection developed under the direction and signed by a Certified Safety Professional or other qualified independent consultant shall be submitted and kept on site for the duration of the project. The plan shall be for all Work on this project. The plan shall address known hazards including excavation safety, confined space permit controls, heavy metals including lead, fall protection and fire prevention.
- k. An Environmental Health Protection plan (including storm water pollution prevention best management practices) for all Work on this project shall be developed under the direction of and signed by a licensed P.E. (or other qualified person) shall be submitted and kept on the site for the duration of the project.
- l. Public Safety – The Contractor shall concern himself with public safety at all times during the life of this contract. Work area shall be clearly identified. Public access through the project shall be by means of well-established and delineated corridors. Materials shall be stockpiled in such a manner as to assure no hazard to the public, District Facilities, District Operations or the environment. Tools and equipment shall be likewise kept locked and out of reach. Work area shall be kept free of garbage and other waste.
- m. Dust Control – The Contractor shall comply with all County and other regulatory requirements for dust control. Contractor shall provide adequate personnel and equipment as necessary to abate all dust, which results from either his operation or created by a portion of the Work of this project. Dust control measures shall be in effect during the entire length of this contract including weekends and holidays. Contractor shall designate a contact person responsible for responding to any calls regarding dust issues and implementing dust control measures.

2. Measurement

Measurement of Work associated with Bid Item **No. 1** will be based upon completion of such work as a lump sum.

3. Payment

Payment for this bid item will be made at the lump sum named in the Bid Schedule under Bid Item **No. 1**, which price shall made on a percent complete basis based on the lump sum amount for this item. No portion of payment for “Mobilization and

Construction Coordination” will be approved for payment under the Contract until all pre-job planning and product submittal items listed herein have been completed and approved as specified. The scope of the work included under this bid item shall include the obtaining of all bonds, insurance, permits, submittals, and moving tank construction equipment (including crane, power generation and welders) onto the site.

All submittals shall conform to the requirements of the General Conditions and Specifications and be approved by the Engineer.

The aforementioned amount will be retained by the Owner as the agreed, estimated value of completing all of the mobilization items listed. Any such retention of money for failure to complete all such mobilization items as a lump-sum item shall be in addition to the retention of any payments due to the Contractor.

**B. Replace Tank Roof**

1. Description

This Work includes the furnishing of all tools, equipment, labor and materials required to accomplish all of the following Work within the limits designated on the plans or as directed by the Engineer in accordance with the plans and specifications. The Work includes but is not limited to the following:

- a. Field verification of tank dimensions.
- b. Engineering of any required temporary supports, roof structure, tank connections and foundation, shop drawings, submittals and documentation of contract compliance.
- c. Shop fabrication.
- d. Shop coating.
- e. Temporarily support the roof, shell and other portions of the tank and appurtenances as required.
- f. Temporary door sheet if desired by the Contractor with radiographic testing.
- g. Demolition, removal and recycling of existing roof (includes roof plate and structure down to and including base plates) and all other appurtenances and materials necessary as part of this project.
- h. Adjustment of pitch of the existing compression ring to prevent ponding and facilitate fit-up and welding to the new roof panels.
- i. Erection of new roof structure and all associated elements for a complete roof.
- j. Quality control.
- k. Testing of welds.
- l. Complying with all applicable federal, state, and local regulations.

2. Measurement

Measurement of Work associated with Bid Item **No. 2** will be based upon completion of this work as a lump sum. The measurement shall be made by the contractor and verified by the Owner's representative.

3. Payment

Payment for this bid item will be made at the lump sum named in the Bid Schedule under Bid Item **No. 2**, which price shall be made on a percent complete basis based on the lump sum amount for this item. The lump sum cost shall constitute full compensation for furnishing all labor, materials, tools, and equipment associated with performing all Work involved in providing Work under this bid item in place, operational, and in conformance with the plans & specifications.

**C. Roof Appurtenances, Roof Hatch, Roof Vent, Level Gauge and Guardrail**

1. Description

This Work includes the furnishing of all tools, equipment, labor and materials required to accomplish all of the following Work within the limits designated on the plans or as directed by the Engineer in accordance with the plans and specifications. The Work includes but is not limited to the following:

- a. Field verification of related existing tank and appurtenance dimensions.
- b. Engineering of guardrail, roof hatch, vent, roof fall protection system and associated appurtenances, shop drawings, submittals and documentation of contract compliance.
- c. Demolition, removal and recycling of existing guardrail, roof hatch and all other materials removed as a portion of this work.
- d. Disconnect, remove and dispose of all existing cathodic protection components. Remove primary power wires to the first junction box and abandon buried conduit in-place.
- e. Fabrication and installation new guardrail with protection at all roof edges.
- f. Fabrication and installation of a new roof hatch.
- g. Install two new 1 1/4" Sch 40 spare couplings with plugs on the roof adjacent to the new roof hatch.
- h. Fabricate and install a new level gauge (w/ option to re-use existing gauge channel), attachment and stilling well.
- i. Remove from existing roof and re-attach high inlet piping to the new roof.
- j. Fabricate and install a new roof vent.
- k. Move existing inside ladder safety device extension rack to the new roof.

- l. Finish welds and other surfaces in preparation for coating.
- m. Preparation and coating of new appurtenances.
- n. Quality control.
- o. Complying with all applicable federal, state, and local regulations.

2. Measurement

Measurement of Work associated with Bid Item **No. 3** will be based upon completion of this work as a lump sum. The measurement shall be made by the contractor and verified by the Owner's representative.

3. Payment

Payment for this bid item will be made at the lump sum named in the Bid Schedule under Bid Item **No. 3**, which price shall be made on a percent complete basis based on the lump sum amount for this item. The lump sum cost shall constitute full compensation for furnishing all labor, materials, tools, and equipment associated with performing all Work involved in providing Work under this bid item in place, operational, and in conformance with the plans & specifications.

**D. Spiral Stairway Security Cage and Locking Door**

1. Description

This Work includes the furnishing of all tools, equipment, labor and materials required to accomplish all of the following Work within the limits designated on the plans or as directed by the Engineer in accordance with the plans and specifications. The Work includes but is not limited to the following:

- a. Field verification of related existing tank and appurtenance dimensions.
- b. Engineering of hot dip galvanized double stringer spiral stairway and associated appurtenances, shop drawings, submittals and documentation of contract compliance
- c. Finishing welds and other surfaces in preparation for coating
- d. Preparation and coating (HDG) of all stairway components (including security cage and gate).
- e. Quality control
- f. Complying with all applicable federal, state, and local regulations

2. Measurement

Measurement of Work associated with Bid Item **No. 4** will be based upon completion of this work as a lump sum. The measurement shall be made by the contractor and verified by the Owner's representative.

3. Payment

Payment for this bid item will be made at the lump sum named in the Bid Schedule under Bid Item **No. 4**, which price shall be made on a percent complete basis based on the lump sum amount for this item. The lump sum cost shall constitute full compensation for furnishing all labor, materials, tools, and equipment associated with performing all Work involved in providing Work under this bid item in place, operational, and in conformance with the plans & specifications.

**E. Interior Coatings**

1. Description

This Work includes the furnishing of all tools, equipment, labor and materials required to accomplish all of the following Work within the limits designated on the plans or as directed by the Engineer in accordance with the plans and specifications. The Work includes but is not limited to the following:

- a. Preparation of interior surfaces of the existing tank and appurtenances for coatings
- b. Containment of dusts, mists and other objectionable airborne materials
- c. Application of coatings on interior surfaces and appurtenances
- d. Preparation and application of coatings on interior surfaces of the underground and aboveground piping (first six inches from tank)
- e. Preliminary wash of all interior surfaces, piping and components prior to disinfection
- f. Disinfection of tank interior surfaces
- g. Disinfection of piping and any other surfaces, affected by the work that are within the potable water storage and distribution system
- h. Protecting and repairing coatings damaged during disinfection and other work
- i. Sealing the tank manways
- j. Quality control

2. Measurement

Measurement of Work associated with Bid Item **No. 5** will be based upon completion of this work as a lump sum. The measurement shall be made by the contractor and verified by the Owner's representative.

3. Payment

Payment for this bid item will be made at the lump sum named in the Bid Schedule under Bid Item **No. 5**, which price shall be made on a percent complete basis based on the lump sum amount for this item. The lump sum cost shall constitute full compensation for

furnishing all labor, materials, tools, and equipment associated with performing all Work involved in providing Work under this bid item in place, operational, and in conformance with the plans & specifications.

**F. Exterior Coatings**

1. Description

This Work includes the furnishing of all tools, equipment, labor and materials required to accomplish all of the following Work within the limits designated on the plans or as directed by the Engineer in accordance with the plans and specifications. The Work includes but is not limited to the following:

- a. Preparation and coating of exterior surfaces of the existing tank
- b. Protection of property
- c. Containment of dusts, mists and other objectionable airborne materials
- d. Quality control

2. Measurement

Measurement of Work associated with Bid Item **No. 6** will be based upon completion of this work as a lump sum. The measurement shall be made by the contractor and verified by the Owner's representative.

3. Payment

Payment for this bid item will be made at the lump sum named in the Bid Schedule under Bid Item **No. 6**, which price shall be made on a percent complete basis based on the lump sum amount for this item. The lump sum cost shall constitute full compensation for furnishing all labor, materials, tools, and equipment associated with performing all Work involved in providing Work under this bid item in place, operational, and in conformance with the plans & specifications.

**G. Welded Patches**

1. Description

This Work includes the furnishing of all tools, equipment, labor and materials required to accomplish all of the following Work within the limits designated on the plans or as directed by the Engineer in accordance with the plans and specifications. The Work includes but is not limited to the following:

- a. Provide submittals including welding procedures and welder qualifications.
- b. Fabricate 1/4" thick patch plates as required to repair the specified areas.
- c. Seal weld patch plates on tank to repair bottom corrosion or other miscellaneous locations as directed by the Engineer or Owner's Representative.

2. Measurement

Measurement for Bid Item **No. 7** Work will be based upon completion of these items on a unit cost basis for each sq. ft. as specified by the Engineer. The measurement shall be made by the contractor and verified by the Owner's Representative.

3. Payment

Payment for Bid Item **No. 7** shall be made on a unit cost basis. The unit cost shall constitute full compensation for furnishing all labor, materials, tools, and equipment associated with performing all Work involved in providing the Work associated with this Bid Item in place, operational, and in conformance with the plans & specifications.

**H. Demobilization**

1. Description

This work includes the furnishing of all tools, equipment, labor and materials required to accomplish all of the following Work within the limits designated on the plans or as directed by the Engineer in accordance with the plans and specifications. The Work includes but is not limited to the following:

- a. Demobilization – Contractor shall move off all equipment, materials, etc. as necessary to complete all aspects of this project.
- b. Handle, sample, test, transport and recycle spent abrasive which will contain lead and other heavy metals from existing coatings
- c. Construction Clean-Up – The Contractor is responsible for leaving the project areas in suitable condition for operation. It is imperative that all contractor Work, stockpile, storage, and equipment areas be completely clean and free of foreign material, materials removed or replaced as part of this work, gravel, aggregate base, broken asphalt, pipe, hardware, packing material, welding debris, and concrete when the Work is complete. All said material shall be picked up and removed from the site and not scattered. All removals from the site shall be done so in a legal manner. Contractor is responsible for all costs associated with loading, hauling, and dumping including any required permits, fees, etc
- d. Daily housekeeping and site control.
- e. Maintenance of storm water pollution prevention plan controls.
- f. The Contractor shall provide slope stabilization and other measures required to prevent sedimentation or other contamination of water draining from the site as a result of construction activities and this project.
- g. Miscellaneous – All items which are shown on the plans or identified in the specification or implied thereby, or incidental to any of the described items, even though not specifically called out in a particular item shall be included as part of this bid item.

2. Measurement

Measurement for Bid Item **No. 8** "Demobilization" will be based upon completion of such work as a lump sum. The measurement shall be made by the contractor and verified by the Owner's representative.

3. Payment

Payment for Bid Item **No. 8** "Demobilization" shall be made in a lump sum amount for this item. **No payment shall be made until full completion of the Work within the bid item.** The lump sum cost shall constitute full compensation for furnishing all planning, acquisition, labor, materials, tools, and equipment associated with performing all Work involved in demobilizing, stabilizing and returning the site in a fully operable condition.

END OF SECTION



Section 09905

## PROTECTIVE COATINGS

### PART 1 - GENERAL

#### 1.01 SCOPE SUMMARY

- A. The work described in this section covers protective coatings for the project including the interior and exterior surfaces of one existing water tank, accessible portions of piping, appurtenances. The project goals are to achieve coating systems that provide long term service, good aesthetics and with low maintenance cost while using best safety and environmental practices.
- B. The contractor shall supply all coatings, solvents, abrasives, air compressors, hoses, paint guns, materials storage and any other tools, equipment and consumables necessary for the proper preparation and application of the coatings.
- C. The Contractor shall be familiar with the service conditions of the tank and shall submit preparation and coating applications as appropriate. The Contractor shall consult the Engineer prior to any coating activity where the coating of certain components or surfaces is in question.
- D. The Contractor shall provide containment for abrasives, dusts, mists and other objectionable materials to protect neighboring homes, adjacent equipment and other property.

#### 1.02 RELATED WORK SPECIFIED ELSEWHERE

- A. Section 01100, Scope and Control of the Work
- B. Section 1205, Measurement and Payment
- C. Section 13010, Upgrades to the Existing Tank
- D. Section 13020, Replace Water Tank Roof

#### 1.03 REFERENCES

- A. Without limiting the general aspects or other requirements of this specification, work and equipment shall conform to applicable requirements of County, State and Federal codes, laws and ordinances governing the work, American Water Works Association, SSPC: The Society of Protective Coatings, and the manufacturer's printed instructions.
- B. When conflict exists between any of the referenced codes, laws, ordinances, specifications and standards contained herein, the most conservative relative to the project goal of system longevity shall govern.
- C. The latest edition of the following standards and regulations form a part of this specification. Materials, preparation, application, repair methods, and all other aspects of the work and inspections shall conform to following codes and standards:

1. AMERICAN SOCIETY FOR TESTING AND MATERIALS (ASTM)
  - a. ASTM D1186, Standard Test Method for Nondestructive Measurement of Dry Film Thickness of Nonmagnetic Coatings Applied to a Ferrous Base
  - b. ASTM D3359, Standard Test Method for Measuring Adhesion by Tape Test
  - c. ASTM D4138, Standard Practices for Measurement of Dry Film Thickness of Protective Coating Systems by Destructive, Cross-Sectioning Means
  - d. ASTM D4285, Standard Test Method for Indicating Oil or Water in Compressed Air
  - e. ASTM D4414, Standard Practice for Measurement of Wet Film Thickness by Notch Gages
  - f. ASTM D4417, Standard Test Methods for Field Measurement of Surface Profile of Blast Cleaned Steel
  - g. ASTM D5402, Standard Test Methods for Assessing the Solvent Resistance of Organic Coatings Using Solvent Rubs
2. AMERICAN WATER WORKS ASSOCIATION (AWWA)
  - a. AWWA D102-19, AWWA Standard for Coating Steel Water-Storage Tanks
  - b. AWWA M42, AWWA Manual of Water Supply Practices, Steel Water Storage Tanks
  - c. AWWA C652-02, AWWA Disinfection of Water-Storage Facilities
3. SOCIETY OF PROTECTIVE COATINGS (SSPC)
  - a. SSPC-PA 1, Shop, Field, and Maintenance Painting of Steel
  - b. SSPC-PA 2, Measurement of Dry Coating Thickness with Magnetic Gages
  - c. SSPC-VIS 1, Visual Standard for Abrasive Blast Cleaned Steel
  - d. SSPC-VIS 3, Visual Standard for Hand and Power Tool Cleaned Steel
  - e. SSPC Publication No. 91-12, Coating and Lining Inspection Manual
  - f. SSPC Visual Comparison Manual
  - g. SSPC-SP 1, Solvent Cleaning
  - h. SSPC-SP 3, Power Tool Cleaning
  - i. SSPC-SP 7, Brush-off Blast Cleaning
  - j. SSPC-SP 10, Near-White Metal Blast Cleaning
  - k. SSPC-SP 11, Power Tool Cleaning to Bare Metal

- I. SSPC-SP 12, Surface Preparation and Cleaning of Metals
- 4. NACE INTERNATIONAL (NACE)
  - a. NACE SP0188-2006, Standard Practice for Discontinuity (Holiday) Testing of New Protective Coatings on Conductive Substrates
  - b. NACE RP 0178-89, Standard Recommended Practice for Fabrication Details, Surface Finish Requirements, and Proper Design Considerations for Tanks and Vessels to be Lined for Immersion Service.
- D. NATIONAL SANITATION FOUNDATION (NSF)
  - 1. NSF 61, Drinking Water System Components - Health Effects
- E. EQUIPMENT AND COATING MANUFACTURER'S PUBLISHED INSTRUCTIONS

#### 1.04 SUBMITTALS

- A. Submittals shall be provided in accordance with these special provisions. **The Contractor shall provide submittals before the pre-job conference.** No work shall be done on items needing submittal approval until the material or plan is approved by the Owner.
- B. Required Submittals. Submittals shall be furnished by the contractor as called for in the various sections of these Special Provisions and for following items as a minimum:
  - 1. Coatings/Color (each coat)
  - 2. Solvents/Thinners
  - 3. Abrasives
  - 4. Magnetic Dry Film Thickness Gage
  - 5. Coating Conditions Verification Equipment (Temperatures/Humidity)
  - 6. Daily Report Form
  - 7. Caulking (See Coating Systems)
  - 8. Holiday detection equipment with voltage verification/calibration method
  - 9. Containment method for abrasives, dusts, mists and other objectionable materials to protect property
- C. Product Submittals. Approval of materials and products by the Owner does not waive the Contractor's responsibility to provide a material which will meet the project goals.
- D. Coating Submittals. The submittals for coating products shall, at a minimum, contain the following information:
  - 1. Material Name / Manufacturer
  - 2. Standards of which the product complies

3. Conditions for which the product was developed or can be used
4. Application guidelines including manufacturer approved field repair method of shop applied primers
5. Testing information / data on product
6. Any material guarantees
7. Expected life
8. Surface Preparation for coatings including any special requirements for this project
9. Recommended uses
10. Safety precautions - and MSDS sheets
11. Name and phone number of the area sales representative for the product
12. Any other information the contractor feels would be helpful in the Owner's review

#### 1.05 OSHA COMPLIANCE.

- A. Contractor shall comply with all applicable regulations including state and federal OSHA and these Special Provisions.
- B. Contractor is responsible for complying with Cal/OSHA regulations for lead in construction in accordance with California Code of Regulations, California Title 8, Section 1532.1. Lead. Some levels of lead are undoubtedly present and Cal/OSHA requires compliance with 1532.1 if the paint contains lead at any level.
- C. The costs for complying with all OSHA requirements shall be considered as included in the various contract prices paid and no additional compensation will be allowed. Contractors are welcome to take lead samples in advance by arrangement with the owner.

## **PART 2 - PRODUCTS**

### 2.01 ABRASIVES

- A. Abrasive used in blast cleaning operations shall be recyclable fused copper slag. Abrasives shall meet all requirements of the California Air Resources Board for content and emissions.
- B. Abrasives shall be certified for unconfined dry blasting pursuant to the California Administrative Code, Section 92520 of Subchapter 6, title 17, and shall appear on the current listing of approved abrasives.

### 2.02 CAULKING

- A. The caulking sealant shall be a premium-grade, high-performance, moisture-cured, 1-component, polyurethane-based, non-sag elastomeric sealant that meets ASTM C-920, Type S, Grade NS, Class 25 such as Sika 1a or equivalent. The material shall be capable of  $\pm 25\%$  joint movement and withstand submerged conditions. The material shall have

excellent resistance to aging, weathering and maintain elasticity during long term exposure in the given conditions.

## 2.03 COATING MATERIALS.

- A. Coating materials shall conform to the following requirements:
1. Only high-grade products of manufacturers having an established good reputation in the manufacture of quality protective coatings shall be used. All coatings on the interior surfaces of the tank or other areas that can contain potable water shall conform to NSF-61(including NSF-600).
  2. Coating materials shall be brought to the job site in the original sealed containers. Materials found to be damaged or out of date shall be removed from the site. Materials shall be stored in an enclosed structure out of the weather protecting them from excessive heat or cold.
  3. The Contractor may submit paint materials of manufacturer's other than those specified herein in accordance with these Special Provisions. The Contractor shall provide satisfactory documentation from the firm manufacturing the proposed material that the material meets the specified requirements and is equivalent to or better than the listed materials in the following properties:
    - a. Quality
    - b. Durability
    - c. Resistance to abrasion and physical damage
    - d. Life expectancy
    - e. Ability to recoat in future
    - f. Solids content by volume
    - g. Dry film thickness per coat
    - h. Compatibility with other coatings
    - i. Suitability for the intended service
    - j. Resistance to chemical attack
    - k. Temperature limitations in service and during application
    - l. Type and quality of recommended undercoats and topcoats
    - m. Ease of application
    - n. Ease of repairing damaged areas
    - o. Stability of color

## **PART 3 - EXECUTION**

### 3.01 HOUSEKEEPING AND CLEANUP

- A. At the end of each work day, dust, paint chips and abrasive shall be removed from the surfaces and surrounding areas. Spent abrasive shall be stored in temporary storage containers on site pursuant to Best Management Practices and Best Pollution Prevention Practices listed under federal and state guidelines.
- B. As work proceeds, promptly remove all coating that is spilled, splashed, or splattered. Collect empty containers, rags, waste material, and debris and store or remove from the site as appropriate.
- C. The site shall be maintained free of unnecessary accumulations of tools, equipment, surplus materials, and debris. Equipment maintenance and spill prevention procedures shall be adequate to prevent spills and leaks.
- D. Upon completion of the work, the Contractor shall remove all excess materials, equipment, containers, and waste from the job site. Coating spots or stains shall be removed from adjacent surfaces and surfaces repaired if needed.

### 3.02 PROTECTION OF PROPERTY

- A. The Contractor shall prevent any airborne materials including mists or dusts or abrasive blast residue or overspray from leaving the District's property.
- B. The Contractor shall provide, operate and maintain filtered ventilation on the tank during interior preparation and coating. The filtration shall contain and prevent the drifting of particulates including but not limited to abrasive blast residue and overspray preparation and coating.
- C. Open air abrasive blasting is prohibited except when containment is provided.
- D. Spray application of coatings is prohibited except when containment is provided.
- E. The Contractor shall protect the following surfaces from abrasive blasting, entry of sand, grit, dust and paint or other damage by wrapping, masking or other methods:
  - 1. PVC piping including high inlet on tank interior
  - 2. Sheet metal siding
  - 3. Any pump/motors
  - 4. Threaded portions of valve and gate stems
  - 5. Machined surfaces for sliding contact, bearings, sprockets or gears
  - 6. Surfaces to be assembled against gaskets
  - 7. Mechanical drives
  - 8. Stainless steel or aluminum surfaces not specifically designated for coating or painting
  - 9. Coated or plated items (including galvanized) not scheduled for painting or coating

- 10. Drains & relief valves
- 11. Concrete surfaces
- 12. All other surfaces not specifically designated for coating or painting.

- F. If required to prevent damage, protective coverings or drop cloths shall be used to protect floors, fixtures and equipment. The Contractor shall mask, cover and shield all gauges, instruments, stainless steel, aluminum, galvanized steel, glass, plastic, equipment and all other surfaces not intended for coating as specified. Surfaces, from which inadvertently applied materials cannot be removed satisfactorily, shall be recoated or repainted to produce a finish satisfactory to the Owner.
- G. Coating application to exterior surfaces shall be completed using roller and brush methods when containment is not provided. The Contractor shall prevent coating material to spatter, spray or otherwise transfer beyond 35' from the tank.

### 3.03 PRESSURE WASHING

- A. The Contractor shall complete low-pressure water cleaning of surfaces prior to other applicable surface preparations. Surfaces shall be cleaned in accordance with SSPC-SP12 LP WC. All oil, grease, salts, rust, loose materials or other contaminants that will adversely impact adhesion or cause coating failure shall be removed.
- B. Pressure washing can be destructive to nonmetallic surfaces. Hydraulic pressure of the washer shall be controlled so as to not cause damage to surfaces not designated for painting. The Contractor shall protect wood, insulation, caulking, electric installations and instrumentation from direct and indirect water streams. The Contractor shall cover and protect all instruments and equipment not intended for washing.

### 3.04 SURFACE PREPARATION

- A. Surface preparation shall be provided as detailed for the specific aspects of the work. Surface preparation shall conform to this specification and the applicable material manufacturer's recommendations. The contractor shall provide all necessary testing and **recycle the abrasive** through an approved recycling program. The Contractor shall provide documentation of receipt of the material by the recycler.
- B. All welding shall be completed prior to surface preparation and coating. Do not apply any part of a coating system before the Owner's Quality Assurance has reviewed the surface preparation. Coating applied without inspection shall be removed by abrasive blasting and reapplied in accordance with this specification.

### 3.05 APPLICATION.

- A. Coating application on exterior surfaces may be completed using roller or brush methods. Spray application is not allowed on the exterior unless containment is provided.
- B. Coatings applied to materials prior to forming (i.e., roof panels) shall be removed at least 5 inches away from any bends by abrasive blasting to a commercial blast. Edges shall be feathered.

- C. Thinning shall be permitted as recommended by the manufacturer for the conditions of application and allowed by applicable regulations.
- D. Each application of coating or paint shall be applied evenly, free of sags and runs, with no evidence of poor workmanship. Care shall be exercised to avoid lapping on glass or hardware. Coating and paint shall be sharply cut to lines. Finished surfaces shall be free from defects or blemishes.
- E. When two or more coats of coating or paint are specified, each coat shall be adequately contrasting in color to act as an indicator of coverage.
- F. All material shall be applied in accordance with the manufacturer's recommendations and these specifications. Maximum permissible level of soluble salts or chemicals shall be as recommended by the coating manufacturer and verification shall be the responsibility of the contractor.
- G. At least one brush stripe coat shall be applied, on the interior, to edges, corners, and irregular surfaces such as welds and fasteners. Minimum recoat times shall be observed between the stripe coat and the next coat. The stripe coat may be applied after the prime coat if appropriate.
- H. Where the number of coats or dry film thickness is specified, they shall be considered a minimum. The Contractor shall apply additional coats as necessary to achieve the specified dry film thickness.
- I. Coating procedures and recoat cycles are critical. It is imperative that the manufacturer's recommendations be strictly followed. Any deviation from printed literature must be approved in writing by the manufacturer's technical department and the owner prior to starting alternate procedures.

### 3.06 CONTRACTOR QUALITY CONTROL.

- A. The Contractor is responsible for quality control. The Contractor shall provide adequate equipment to monitor project quality. The Contractor shall document conditions, progress, project personnel and equipment on site, in a daily report. Environmental readings shall be recorded at the beginning and end of each painting sessions. Signed daily reports shall be provided to the Owner Representative on a weekly basis.
- B. No coating or paint shall be applied to wet or damp surfaces, in rain, snow, fog, or mist, when the steel temperature or surrounding air temperature is less than 5 degrees Fahrenheit (5°F) above the dew point, nor in conditions not recommended by the manufacturer. If unacceptable weather conditions are prevalent, coating or painting shall be delayed or postponed until conditions are favorable. The day's coating or painting shall be completed in time to permit the film sufficient drying time prior to damage by atmospheric conditions.
- C. The thickness of coatings shall be checked with a non-destructive, magnetic type thickness gauge. Coating thickness measurement procedures shall be pursuant to SSPC-PA-2. Additional measurements may be made when determined by the inspector to be in the best interest of the project. In cases of dispute concerning film thickness, measurements made with instruments shown to be in calibration with the National Bureau of Standards



calibration plates shall predominate. The contractor shall furnish U.S. Department of Commerce, National Bureau of Standards certified thickness calibration plates to test accuracy of dry-film thickness gauge. All inspection devices shall be in good working order.

Dry film thickness that exceeds the coating manufacturer's recommendation is unacceptable and shall be removed by the Contractor at no extra cost to the Owner.

- D. The coating integrity of all interior coated metallic surfaces shall be tested with an approved high voltage spark testing detection device. Non-submersed roof and shell areas shall be included in the holiday testing. Holiday detection of interfaces between roof plate and rafters which are not seal welded is not required.

The contractor shall provide holiday detection devices in good working order.

All holiday detection devices shall be operated in the presence of a representative of the Owner. Testing shall be conducted pursuant the coating manufacturer's recommendations and NACE RP 0188 (latest edition). All rejected areas shall be marked and repaired in accordance with the manufacturer's printed recommendations and re-tested. No pinholes or other irregularities will be permitted in the final coating.

### 3.07 QUALITY ASSURANCE.

- A. The Owner may provide shop or field inspection of the work. The Contractor shall provide the Owner's Representative with a 3 day notice prior to any surface preparation or coating application. All work shall be performed with the presence of the Owner's Representative unless written prior approval has been granted. Coatings applied without inspection shall be removed by abrasive blasting and reapplied in accordance with this specification.

### 3.08 COATING SYSTEM – EXTERIOR OF EXISTING TANK & ABOVE GROUND FERROUS PIPING

- A. General. All exterior surfaces of the existing tank, above ground piping and appurtenances shall be coated unless noted herein. Level gage, vent screens and other "bolt on" hardware shall be removed prior to preparation and replaced after completion. Electrical conduit, enclosures and instruments shall be loosened from clamps and supported away from surfaces to be painted as appropriate for optimal corrosion protection of tank and appurtenances.
- B. Included Items: All exterior surfaces including above ground piping.
- C. Surface Preparation:
1. Tank exterior: SSPC-SP12 LP WC, hand sand to scarify surfaces and as specified by the coating manufacturer's recommendations.
  2. New materials: See below
  3. Ductile iron piping and fittings: NAPF 500-03-03 Power tool clean
  4. Romac expansion joints: SSPC – SP2 Power tool clean, protect rubber material

- D. Exterior Coating System: Spot prime any bare steel, full barrier/intermediate coat with epoxy followed by aliphatic polyurethane. All coatings shall meet applicable regulatory standards. Examples of coatings are as follows:
1. Devoe
    - a. Spot Prime: Devoe High Performance Coatings Bar-Rust 231 Multi-Purpose Epoxy Mastic, 3 - 5 mils
    - b. Barrier/Intermediate: Devoe High Performance Coatings Bar-Rust 231 Multi-Purpose Epoxy Mastic, 3 - 5 mils
    - c. Finish: Devoe High Performance Coatings Devthane 378H Aliphatic Urethane Semi-Gloss, 2 - 3 mils

or
  2. Carboline
    - a. Spot Prime: Carboguard 890 @ 4-6 mils DFT
    - b. Barrier/Intermediate: Carboguard 890 @ 4-6 mils DFT
    - c. Finish: Carbothane 134VOC @ 2-3 mils DFT

or
  3. Tnemec
    - a. Spot Prime: Tnemec L140F Pota-Pox, 3 - 5 mils
    - b. Intermediate: L140F Pota-Pox, 3 - 5 mils
    - c. Finish: Tnemec 1075 Endura-Shield, 2 - 3 mils
  4. Approved equal.
- E. Color: Submit color for Owner approval. Custom color matching may be required.

### 3.09 COATING SYSTEM – EXTERIOR SURFACES (NEW STEEL)

- A. All exterior surfaces shall be coated unless noted herein. Ladder safety climb rails, level gage board, vent screens and other “bolt on” hardware shall be removed during coating and replaced after completion.
- B. Included Items: All new steel exterior surfaces including, but not limited to, new roof, new appurtenances and new piping.
- C. Surface Preparation: Abrasive blast per SSPC-SP6 Commercial Blast Cleaning (containment required) and the coating manufacturer’s recommendations. Coatings applied to materials prior to forming (i.e., roof panels) shall be removed at least 5 inches away from any bends by abrasive blasting to a commercial blast. Edges shall be feathered.

- D. Exterior Coating System (AWWA D-102 Outside Coating System No. 5). Epoxy prime coat with an epoxy intermediate coat followed by aliphatic polyurethane. Examples of approved coatings are as follows:
1. Devoe
    - a. Primer: Devoe High Performance Coatings Bar-Rust 231 Multi-Purpose Epoxy Mastic, 3 - 5 mils
    - b. Intermediate: Devoe High Performance Coatings Bar-Rust 231 Multi-Purpose Epoxy Mastic, 3 - 5 mils
    - c. Finish: Devoe High Performance Coatings Devthane 378H Aliphatic Urethane Semi-Gloss, 2 - 3 milsor
  2. Tnemec
    - a. Primer: Tnemec L69 Epoxoline or V140F Pota-Pox, 3 - 5 mils
    - b. Intermediate: Tnemec L69 Epoxoline or V140F Pota-Pox, 3 - 5 mils
    - c. Finish: Tnemec 1075 Endura-Shield, 2 - 3 milsor
  3. Approved equal.
- E. Color: Submit color palette for Owner approval.
- F. Slip Resistant Areas: Provide slip-resistant surfaces by applying 30 mesh walnut shell to an epoxy "stripe coat".

3.010 COATING SYSTEM – INTERIOR SURFACES

- A. Included items: All Interior surfaces.
- B. Surface Preparation: Abrasive blast per SSPC-SP10 Near White Blast Cleaning and the coating manufacturer's recommendations.
- C. Interior Coating System (AWWA D-102 Inside Coating System No. 2): Three coat, two component epoxy coating system. A prime, intermediate and finish coat of two component epoxy. An example of approved coatings is as follows:
1. Tnemec
    - a. Primer: Tnemec L140 Pota-Pox, 3 mils
    - b. Intermediate: Tnemec L140 Pota-Pox, 4 mils
    - c. Finish: Tnemec L140 Pota-Pox, 5 mils

or

2. Sherwin Williams

- a. Primer: SherPlate 600 @ 3 mils DFT
- b. Intermediate: SherPlate 600 @ 4 mils DFT
- c. Finish: SherPlate 600 @ 5 mils DFT

or

3. Approved equal.

D. Color: Tank white

3.011 CURING AND VENTILATION

- A. Forced ventilation of the tank interior shall be conducted for a period equal or exceeding the coating manufacturer's recommended minimum recoat time for each coat and for at least 48 hours after the final coat. The ventilation shall be equal to or greater than specified in AWWA D102. Circulation through low areas of the tank, piping and other associated areas that will hold solvent vapors shall be assured.
- B. If heating or dehumidification are required for proper curing, the Contractor shall provide these as a part of the Base Bid and at no additional cost to the Owner.

3.012 CAULKING

- A. Caulk shall be applied to unsealed joints such as bolts, nuts, bolted flanges etc. to prevent moisture intrusion and rust staining ("bleeding"). Minimum recoat times for caulking shall be followed. Caulk shall be applied only to clean dry areas that are free of loose materials and dust. Follow manufacturer's installation instructions. Caulk shall be applied between the prime and finish coats.

3.013 LABELING

- A. Label inside of roof hatch "**FALL HAZARD PROTECT OPENING OR MONITOR WHEN OPEN – CONFINED SPACE ENTRY BY PERMIT ONLY**". Labeling shall be located on the inside of the hatch lid. The labeling shall be done with red or black colored NSF 61 approved epoxy. Letters shall be neatly stenciled and shall be 2" tall or larger.
- B. Label the shell adjacent to the level gauge or other location as directed by the Owner with the maximum operating level as follows: "**MAXIMUM OPERATING LEVEL: XX' - XX**" (actual value per the Contractor's Engineer). Letters shall be neatly stenciled and shall be 2" tall or larger.

3.014 CERTIFICATE OF COMPLIANCE

- A. The Contractor shall provide a Certificate of Compliance stating that "The Coating Work has been completed in conformance with the Specifications and Curing has been completed and confirmed pursuant to the Project Specifications and the coating

manufacturer's recommendations and the tank is ready to be filled." The Certificate of Compliance shall be provided to the Owner and Engineer prior to disinfection.

3.015 TANK DISINFECTION.

- A. After cure of the interior coating has been completed, the interior of the tank shall be thoroughly cleaned and disinfected. All work shall conform to the requirements of ANSI/AWWA C652, Standard for Disinfection of Water-Storage Facilities, Method 2. The Contractor shall test the disinfection solution for chlorine concentration during the observation of the Owner Representative and prior to start of disinfection. Upon completion of disinfection, the Owner's representative shall photograph the tank interior and the Contractor shall seal the tank.

3.016 SOAK TEST AND MONITORING

- A. The Owner will fill the tank and complete the five day soak test and VOC monitoring including organics listed on the coating manufacturer's MSDS. The reservoir must also be sampled for coliforms and have satisfactory results. The Owner shall submit the results of all monitoring and testing to the State Water Resources Control Board and receive approval prior to putting the reservoir into service.

3.017 WARRANTY INSPECTION.

- A. The Owner shall provide for inspection of any or all of the work completed under this contract. The date and method of the inspection shall be established and notification given at least 30 days in advance. If an inspection date has not been established within 13 months after completion of the coating work, the first anniversary inspection shall be considered waived. Waiver of the warranty inspection will not relieve the Contractor of the responsibility to repair defective work.

3.018 WARRANTY REPAIR.

- A. If any work is found to be defective, as determined by the Owner, its employees or consultants, the Contractor shall promptly correct the defective work with no cost to the Owner.
- B. The surfaces shall be prepared and re-coated as per the applicable original coating system. Preparation and application procedures for coating repairs shall conform to manufacturer's recommendations and be approved by the Owner with the intent of bringing the defective areas up to the quality level of the original work required by this specification.
- C. The Owner may require delay of repair where necessary for efficient operation of the water treatment facility. If the Contractor does not complete corrective work promptly, the Owner may complete the work itself or hire others to complete it. The original Contractor and its Surety will be liable to the Owner for all direct and indirect costs.

END OF SECTION

Section 13010

## UPGRADES OF THE EXISTING TANK

### PART 1 - GENERAL

#### 1.01 SUMMARY

The intent of the work described in this section is to provide a safe workplace and fully operational potable water tank system.

#### 1.02 SCOPE

- A. Demolish, remove and recycle the applicable existing components that are being replaced or upgraded.
- B. Design, fabricate, install, and coat upgrades on the existing tank in order to provide a safe workplace and assure compliance with applicable regulations. The Contractor's work will include verification of all dimensions (40FT. HEIGHT ON EXISTING NAMEPLATE IS KNOWN TO BE INCORRECT) and engineering by the Contractor's Engineer for all work.
- C. Remove all cathodic protection system components and primary power to first junction box.
- D. Upgrade the access, roof guardrail and other appurtenances to current regulations (including OSHA Standards and State Health Regulations) and these special provisions. The dimensions provided herein are intended to be general information. The Contractor shall field verify all dimensions prior to fabrication.
- E. The Contractor shall design, fabricate, and erect all aspects of the repairs pursuant to AWWA D100-21 (including Section 13 for seismic design), CBC 2022, California Department of Public Health Drinking Water Statutes, and all other applicable rules and regulations. NSF/ANSI 61 (including NSF 600), Standard for Drinking Water System Components shall apply. All contractor design calculations and drawings shall be stamped by a Registered Professional Civil or Structural Engineer with design experience on over 50 similar welded steel tanks.

#### 1.03 RELATED WORK SPECIFIED ELSEWHERE

- A. Section 01100, Scope and Control of the Work
- B. Section 1205, Measurement and Payment
- C. Section 09800, Protective Coatings
- D. Section 13020, Replace Water Tank Roof

#### 1.04 REFERENCES

The latest edition of standards and regulations herein form a part of this specification. Design details, repair methods, fabrication, erection, and all other aspects of the work and inspections shall conform to following Codes and Standards:

- A. AMERICAN WATER WORKS ASSOCIATION (AWWA)
  - 1. AWWA D100-21, AWWA Standard- Welded Carbon Steel Tanks for Water Storage
- B. CALIFORNIA BUILDING STANDARDS COMMISSION (CBSC)
  - 1. CBC 2022, California Building Code (including electrical, mechanical, etc.)
- C. NATIONAL ASSOCIATION OF CORROSION ENGINEERS (NACE)
  - 1. NACE SP0178-2007, Design, Fabrication, and Surface Finish Practices for Tanks and Vessels to Be Lined for Immersion Service.
- D. AMERICAN SOCIETY OF CIVIL ENGINEERS (ASCE)
  - 1. ASCE/SEI 7, Minimum Design Loads For Buildings and Other Structures
- E. NATIONAL SANITATION FOUNDATION (NSF)
  - 1. NSF 61, Drinking Water System Components - Health Effects.
- F. AMERICAN PETROLEUM INSTITUTE (API)
  - 1. API 653, Tank Inspection, Repair, Alteration and Reconstruction, API Standard 653-2018 w/ Addendum 2 (2020)

#### 1.05 SUBMITTALS

Engineering calculations shall be provided to show the adequacy of structural items where loads are specified by applicable industry standards. The design calculations and detailed drawings shall be signed by a Civil or Structural Engineer licensed to practice in the state of California.

- A. Tank roof structure and accessory drawings and supplemental information will include the following:
  - 1. Dimensional drawings indicating size and thickness of all members
  - 2. Attachment details
  - 3. List of appurtenances
  - 4. Fabrication details
  - 5. All details of welded joints. Weld joint details shall include, size, joint preparation, identification of field welds, and indication of welds requiring low hydrogen procedures.
- B. Welding Procedures
- C. Welder Certifications
- D. Mill Test Reports

## PART 2 - PRODUCTS

### 2.01 PLATE AND SHEET

- A. Plate and sheet materials shall conform to the design requirements of AWWA D100.

### 2.02 TANK ACCESSORIES

#### A. ROOF VENT

Provide a 37-inch roof vent. The vent openings shall be concealed under the lid to reduce the number of air-borne particles allowed to enter the tank. The venting area shall be covered with an 8-mesh bronze insect screen. The vent covers shall be hinged and lockable to allow ease of opening for inspection and to help prevent unauthorized removal. The vent covers shall be made of fiberglass to allow installation and removal by two persons. With the lid off, the 37" diameter vent shall readily accept installation of common industrial fans for forced ventilation. To deter subversive damage, the screen clamping system is only accessible with the vent lid removed. All brackets, connection points, wear points, hinges and fasteners, shall be AISI 316 stainless steel. Stainless steel to carbon steel welds shall be completed with E309 stainless steel or another approved electrode.

#### B. ROOF GUARDRAIL

Roof guardrails shall be provided at the entire perimeter of the roof edge except the stairway platform opening. Size of posts and rails and the height of the guardrail assemblies shall comply with applicable state and federal regulations and AWWA D100. All guardrail and components shall be hot dip galvanized.

Guardrails shall be steel with a top rail, mid rail(s), and vertical posts. Spacing between vertical posts shall match existing and shall be spaced a maximum of 7'-0" apart. Guardrail shall include a 4" x 1/4" toeboard. The toeboards shall be provided with bolted attachment to allow removal for painting and maintenance. The Contractor shall notify the Owner's Representative for final inspection.

The guardrail opening at the stairway platform shall be protected with a self-closing safety gate such as Fabenco XL71-36 or equal. The gate shall provide a minimum of 22" of vertical coverage, be fabricated from A36 steel with stainless steel spring and shall be hot dip galvanized.

#### C. DOUBLE STRINGER STAIRWAY

Provide a spiral stairway that meets OSHA requirements. The double stringer stairway design shall eliminate unwelded inaccessible areas. The treads shall bolt to inner and outer stringers. Brackets and gussets shall clear all shell joints pursuant to AWWA D100 requirements. Treads shall be the bar grating type. Treads shall be 30" wide. Maximum riser per step shall be 8". Guardrailing and separate handrailing are required. All parts shall be hot dip galvanized for optimum corrosion resistance. The lower xx of the stairway shall have a climb resistant "cage". The entrance to the stairway shall include a lockable security gate.



D. LEVEL INDICATOR WITH STILLING WELL

The Contractor shall provide a target type liquid level indicator. The indicator board shall be a one-piece extruded 6" aluminum channel (existing aluminum channel may be re-used but w/ new indicator tape). A bolt together board will not be acceptable. The indicator tape shall be pre-printed solid vinyl. Painted markings are not acceptable. The level pointer "target" shall be made from 3/16" galvanized steel. The target shall be balanced to eliminate binding during target movement. The internal hollow float shall be made of heavy gauge stainless steel. The float shall be contained within a pvc stilling well that runs from 6" above the top of the overflow to 2" above the top of the tank bottom. The stilling well shall be attached at a minimum of two points to the tank shell using stainless steel clamps. The stainless clamps shall be painted and electrically isolated from the shell. Shell attachments shall be carbon steel flat bar or angle with a minimum size of 3/8" x 2". All parts, including cable conduits, tensioners, and bottom anchors, shall be made of corrosion resistant materials. The level gage shall be full length.

E. SQUARE ROOF HATCH

Provide a 39" square hinged roof hatch to comply with requirements of OSHA and AWWA D100 for fixed ladders. Stainless steel hinges and latches are required to protect inaccessible wear points. The internal ladder shall extend to, and be welded to, the inside of the roof hatch curb.

F. TANK NAME PLATE (REPLACEMENT ROOF)

The tank shall be provided with an additional new stainless steel name plate located over the manway designated by the owner's representative. At a minimum, the following information shall be engraved into the name plate in letters and numerals not less than 5/32 inch high:

1. Design Standard and date ref. "ROOF REPLACEMENT"
2. The year the tank roof was completed
3. Nominal height (feet and inches), EXISTING NAME PLATE SHOW 40' WHICH IS INCORRECT
4. Nominal diameter (feet and inches)
5. Design maximum operating level (feet and inches) for required freeboard.
6. Nominal capacity (gallons)
7. Fabricator and Erector

G. SPARE ROOF COUPLINGS

1. Install two extra heavy half couplings with plugs in the roof adjacent to the new roof hatch (location per owner representative).

H. WELDED PATCHES

### **PART 3 - EXECUTION**

#### **3.01 REMOVE EXISTING APPURTENANCES**

- A. Remove the existing exterior ladder.

#### **3.02 REMOVE EXISTING CATHODIC PROTECTION SYSTEM**

- A. Remove all cathodic protection system components including all on-tank items such as conduit, wiring and anodes
- B. Remove all CP related items including the post adjacent to the tank and the mounted rectifier cabinet.
- C. Trace primary power back to the nearest junction box and pull existing wires out of the conduit between the junction box and the tank.
- D. Cap and abandon underground conduit in place.
- E. All work shall be done by a qualified person with a minimum qualification of a California licensed electrician pursuant to regulatory requirements.

#### **3.03 GENERAL FABRICATION AND WELDING**

- A. All corners and edges that are exposed upon completion of fabrication shall be finished to a minimum radius of 1/16" to optimize coating application. Finishing with grinding wheels may produce "hard" corners which are not acceptable. Grinders equipped with "soft pads" or sanding discs on rubber backing are often necessary to produce acceptable finishes without corners and edges.

#### **3.04 WELD PROFILES AND FINISHING**

- A. All weld spatter shall be removed prior to coating. Abrasive blasting is not reliable for removal of all weld spatter, so all weld spatter shall be removed as part of tank erection and prior to the start of abrasive blasting.
- B. Removal of Temporary Attachments
  - 1. All temporary and unnecessary brackets, lugs, and clips (such as those used during erection) shall be removed from the tank. Pits created during removal shall be repaired with consideration of minimum weld length and accepted welding procedures. Welded repairs shall be ground flush. Removal of temporary attachments shall be by grinding followed by sanding to smooth course grinding marks (deeper than 4 mils as measured with profile tape) and radius any angular transitions.

#### **3.05 QUALITY**

- A. Shop and field welding quality control shall be the responsibility of the Contractor. Weld quality assurance inspection will be provided by the Owner's Representative. Safe access and lighting are an important aspect of producing a quality product for both the contractor personnel and quality assurance personnel. Safe access, lighting, and assistance shall be provided by the Contractor for the Owner's Representative(s) using the Contractor's rigging and equipment to allow inspection or observation of all work. This shall be provided by the Contractor at no additional cost.
  
- B. The intent of nondestructive testing on this project is to confirm that welds meet the specified minimum requirements. Testing will be done by sampling welds of the most questionable quality, those under higher stress, or by random selection.

END OF SECTION

Section 13020

## REPLACE WATER TANK ROOF

### PART 1 - GENERAL

#### 1.01 SUMMARY

- A. Replace corroded existing roof with a new fully seal welded formed panel roof for an existing flat-bottom welded steel potable water storage tank.

#### 1.02 SCOPE

- A. The Contractor shall remove and recycle the existing roof and roof structure
- B. The Contractor shall provide a new roof and structure. The new roof shall be a formed structural roof panel system with exterior structure. The roof shall be fully seal welded on the interior and exterior. The tank roof and completed tank system shall be suitable to provide potable water storage and emergency (including post-earthquake fire suppression) service.
- C. The Contractor shall design, fabricate, coat and erect all aspects of the tank roof structure system, including the foundation (center column base plates), pursuant to AWWA D100-21 (including Section 13 for seismic design, CBC 2022, California Department of Public Health Drinking Water Statutes, and all other applicable rules and regulations). NSF/ANSI 61 (Standard for Drinking Water System Components) shall apply.
- D. All contractor design calculations and drawings shall be stamped by a registered Professional Civil or Structural Engineer with design experience on over 50 similar welded steel tanks.
- E. The Contractor may install a temporary shell opening "door sheet" (at their option) for improved access. The temporary door sheet shall conform to AWWA D100 and API 653 (latest). See Part 3, Execution-Quality for special radiographic testing requirements.

#### 1.03 RELATED WORK SPECIFIED ELSEWHERE

- A. Section 01100, Scope and Control of the Work
- B. Section 01205, Measurement and Payment
- C. Section 13010, Upgrades to the Existing Tank
- D. Section 09800, Protective Coatings

#### 1.04 REFERENCES

The latest edition of standards and regulations herein form a part of this specification. Design details, repair methods, fabrication, erection, and all other aspects of the work and inspections shall conform to following codes and standards:

- A. AMERICAN WATER WORKS ASSOCIATION (AWWA)

1. AWWA D100-21, AWWA Standard- Welded Carbon Steel Tanks for Water Storage
2. AWWA C652-19, AWWA Disinfection of Water-Storage Facilities
- B. CALIFORNIA BUILDING STANDARDS COMMISSION (CBSC)
  1. CBC 2022, California Building Code
- C. NATIONAL ASSOCIATION OF CORROSION ENGINEERS (NACE)
  1. Standard RP0178-91, Design, Fabrication, and Surface Finish Practices for Tanks and Vessels to Be Lined for Immersion Service
- D. ASTM INTERNATIONAL
  1. ASTM A53/A53M, Standard Specification for Pipe, Steel, Black and Hot-Dipped, Zinc-Coated, Welded and Seamless
- E. AMERICAN SOCIETY OF CIVIL ENGINEERS (ASCE)
  1. ASCE/SEI 7, Minimum Design Loads for Buildings and Other Structures
- F. AMERICAN PETROLEUM INSTITUTE (API)
  1. API 653-Latest, Tank Inspection, Repair, Alteration and Reconstruction
- G. AMERICAN WELDING SOCIETY (AWS)
  1. AWS D1.1:2010 Structural Welding Code - Steel
- H. NATIONAL SANITATION FOUNDATION (NSF)
  1. NSF 61, Drinking Water System Components - Health Effects

#### 1.05 DEFINITIONS

- A. Roof Structure: For the purposes of this project, roof structure includes all portions of the roof plate and roof support system between the existing shell and the tank bottom. This includes rafter attachments at the shell, roof plate with integral (formed) rafters, rafter bracing, center support, center column and base plate(s).

#### 1.06 SUBMITTALS

- A. Engineering calculations. These will show the structural adequacy of all significant design items on the roof structure including but not limited to support of the roof plate considering its existing thickness, "rafter" sizing, center support, column(s) and base plate(s). The Contractor shall provide additional design calculations to show structural adequacy of additional structural items where structural loads are specified by applicable regulations or industry standards. The design calculations and detailed drawings shall be signed and stamped by a Civil or Structural Engineer licensed to practice in the state.
- B. Drawings and supplemental information. These will include: dimensional drawings (indicating size and thickness of all members), attachment details, fabrication details, testing and inspection requirements and all details of welded joints. Weld joint details shall

include size, joint preparation, identification of field welds and indication of welds requiring low hydrogen procedures.

- C. Welding Procedures (including method for determining flare-groove weld size).
- D. Welder Certifications
- E. Mill Test Reports (including columns, roof plate/"rafters", base plates)
- F. Temporary door sheet design and details drawings (if Contractor selects to use door sheet(s)).

#### 1.07 DESIGN INFORMATION

- A. Diameter: Approximately 40'-0". Dimension shall be confirmed by the Contractor
- B. Shell Height: Approximately 32'-0". Dimensions shall be confirmed by the Contractor (40FT DIMENSION SHOWN ON EXISTING NAME PLATE IS KNOWN TO BE INCORRECT).
- C. The center base plates shall be designed pursuant to 900 psf net allowable soil bearing pressure (in addition to the weight of water).
- D. Roof Type: cone
- E. Roof Structure:
  - 1. The roof shall be a "single bay" design.
  - 2. Roof structure shall be integrally formed with roof plate. The structural sections shall be on the topside of the roof.
  - 3. The roof design shall use a center support that allows access to all areas of the structure for seal welding, coating and inspection.
  - 4. The minimum thickness of the roof shall be 1/4".
  - 5. The lowest column base plate shall be a minimum of 3/4 inch thick. The column shall have "end plates" that are retained laterally but shall be a "floating design" (not welded to the tank bottom).
  - 6. Lowest column base plate(s) shall be welded to the bottom but shall have a floating upper plate.
  - 7. All nuts and bolts in the roof structure shall be hot dip galvanized.
- F. Roof live load: 20 psf
- G. Roof plate minimum thickness: 1/4"
- H. Roof slope: 1" in 12"
- I. Seismic
  - 1. Per ASCE/SEI 7-22

2. Risk Category: IV
  3. Mechanically Anchored: Yes (existing)
  4. Calculate the required freeboard and new maximum operating level. See Paint section for labeling exterior shell at the level gauge and upgrades for new nameplate.
- J. Temporary door sheet: If used, door sheet design shall conform to API 653.

## **PART 2 - PRODUCTS**

### 2.01 BASE PLATES

- A. Plate shall conform to the design requirements of AWWA D100 and ASTM A36

### 2.02 STRUCTURAL SHAPES

A. COLUMN(S)

Columns shall be round tubular with minimum thickness of  $\frac{1}{4}$ ". Pipe shall conform to the design requirements of AWWA D100 and ASTM A53.

B. RAFTERS

Integral rafters – See plate and sheet.

### 2.03 PLATE AND SHEET

- A. Plate and sheet materials shall conform to the design requirements of AWWA D100.

## **PART 3 - EXECUTION**

### 3.01 NEW FORMED PANEL ROOF

A. Removal of Existing Roof and Structure

1. All connections between the existing roof plate and structure and the tank shall be removed with care to preserve and protect the compression ring, shell, and tank bottom. The roof plate connection weld at the compression ring (horizontally oriented flat bar at the top of the shell) shall be ground flush. The top corners of the compression ring shall be radiused ( $1/16$ " ) as specified in "General Fabrication and Welding - Finishing Corners and Edges".
2. The existing compression ring flat bar is known to not be sloped to match the roof pitch. The flat bar slope shall be adjusted using a procedure that preserves the roundness of the shell. An example procedure would be to cut the compression ring radially at an appropriate spacing (approximately 15'), form (bend) downward to match the roof slope and re-weld the butt joints. The finished condition shall eliminate ponding and provide an acceptable fit-up on the interior side of the shell to roof joint.
3. Existing rafter - shell connection brackets ("clips") shall be cut off and remaining welds shall be ground flush.
4. Existing base plates shall be cut off and remaining welds shall be ground flush.

5. Pits created during removal shall be repaired with consideration of minimum weld length and accepted welding procedures. Welded repairs shall be ground flush. Removal of temporary attachments shall be by grinding followed by sanding in order to smooth course grinding marks (deeper than 4 mils as measured with profile tape) and radius any angular transitions.
- B. The new roof and structure shall be installed pursuant to the Contractor's design drawings and all joints or inaccessible areas on the interior and exterior shall be fully seal welded.
- C. Flare bevel and other groove welds shall be completed pursuant to specific welding procedures that allow and assure completion and verification of the design weld size. Minimum parameters required for design weld sizes shall be specified.

### 3.02 QUALITY

- A. Shop and field welding quality control shall be the responsibility of the Contractor. Quality assurance inspection oversight and CBC required special inspection will be provided by the Owner's Representative. To help insure effective and efficient oversight, the Owner's quality assurance shall be conducted by or under the oversight of an experienced tank design engineer with minimum qualifications of a California PE Registration and AWS Certified Welding Inspector. Safe access and lighting are an important aspect of producing a quality product for both the contractor personnel and quality assurance personnel. Safe access, lighting, and assistance shall be provided by the Contractor for the Owner's Representative(s) using the Contractor's rigging and equipment to allow inspection or observation of all work. This shall be provided by the Contractor at no additional cost. The Contractor shall provide written notification to the Owner's Representative at least 48 hours in advance of the start or re-start of each work phase.
- B. Radiographic testing and other AWWA D100 required nondestructive testing shall be provided at the expense of the Contractor. The intent of nondestructive testing on this project is to confirm that welds meet the specified minimum requirements. Radiography shall be conducted pursuant to the requirements of AWWA D100 with the following changes: 100% of all the vertical and horizontal shell welds used to replace the door sheet shall be radiographed. The quantity of locations for radiography in other locations shall be increased by adding one additional location on each of the vertical joints in the lowest two shell rings; the locations for all radiographic testing shall be selected by the Owner's Representative. For each weld where quality is found to be unacceptable, the AWWA D100 procedure will be followed regarding additional locations and two supplementary radiographs shall be taken at locations selected by the owner's representative (in addition to the "tracer" locations required by AWWA D100). A copy of the radiographic inspection report shall be provided to the Owner's Representative.

### 3.03 GENERAL FABRICATION AND WELDING

- A. Finishing of Corners and Edges

All corners and edges that are exposed upon completion of fabrication shall be finished to a minimum radius of 1/16" to optimize coating application. Finishing with grinding wheels may produce "hard" corners which are not acceptable. The Contractor shall use grinders equipped with "soft pads" or sanding discs on rubber backing where required to produce acceptable finishes and rounding of corners and edges.



B. Weld Profiles and Finishing

The maximum weld reinforcement allowed by AWWA D100 shall be reduced by 1/32" for all butt joints on this project. Weld reinforcement shall transition to the base metal in a manner that minimizes the mechanical notch at the toe of the weld. The maximum angle between the weld reinforcement and the adjoining base metal shall be 45 degrees. Welds with a less gradual transition shall be repaired by grinding followed by sanding to smooth course grinding marks (deeper than 4 mils as measured with profile tape) and radius any angular transitions.

All weld spatter shall be removed prior to coating. Abrasive blasting is not reliable for removal of all weld spatter so all weld spatter shall be removed as a part of tank erection and prior to the start of abrasive blasting.

C. Removal of Temporary Attachments

All temporary and unnecessary brackets, lugs, and clips, such as those used during erection, shall be removed from the tank. Pits created during removal shall be repaired with consideration of minimum weld length and accepted welding procedures. Welded repairs shall be ground flush. Removal of temporary attachments shall be by grinding followed by sanding in order to smooth course grinding marks (deeper than 4 mils as measured with profile tape) and radius any angular transitions.

3.04 DOOR SHEET

A. If the Contractor chooses to use a door sheet (temporary shell opening), the removal and installation shall be pursuant to API 653 and the following:

1. All welding shall be with low hydrogen processes.
2. Plate edges shall be built up with low hydrogen electrode to replace material lost in the kerf of the cut during the removal of the door sheet. This must be done prior to beveling. The purpose is to help prevent a flat spot in the shell upon replacement.
3. See Quality section for special radiography requirements.

**END OF SECTION**

# **PART IV**

## **APPENDICES**

# **APPENDIX A**

## **COATINGS HEAVY METALS TESTING**



**Asbestos Inspections of SLO**

www.sloasbestos.com

## METALS IN COATING SURVEY REPORT



**Oceano Community Services District Tank Farm**

**1935 19<sup>th</sup> Street**

**Oceano, CA 93445**

**May 3, 2023**

Prepared by:

Mike Bruffey  
Asbestos Inspections SLO  
9517 Carmel Road  
Atascadero, CA 93422  
Phone: (805) 235-0582

Prepared for:

William Bellis  
Advantage Technical Services, Inc.  
6661 Fern Canyon Road  
San Luis Obispo, CA 93401  
(805) 748-6726

9517 Carmel Road, Atascadero, CA 93422 – (805) 235-0582 – bruffey@att.net



## Asbestos Inspections of SLO

www.sloasbestos.com

9517 Carmel Road, Atascadero, CA 93422

Phone: (805) 235-0582

Email: bruffey@att.net

May 3, 2023

William Bellis  
Advantage Technical Services, Inc.  
6661 Fern Canyon Road  
San Luis Obispo, CA 93401  
(805) 748-6726 | wbellis.ats@gmail.com

Re: Metals in Small Water Tank Coating Report Summary  
1935 19<sup>th</sup> Street, Oceano, CA 93445

I have completed the requested coating sampling survey on the small water tank located in the Oceano Community Services District water tank farm. The smaller of the two water tanks are scheduled for maintenance to repair corroded portions prior to recoating. The paint/coating is in poor condition and several areas with severe corrosion were noted.

This survey on April 26, 2023, involved sampling, cataloging, and analyzing coatings collected from the number 1 tank ring and the top to test for the presence of lead, chromium, and cadmium by ICP (inductively coupled plasma) laboratory analysis. Two samples were obtained: one from the north side ring and one from the top section. Relatively low levels of all three metals were detected in both samples. Results can be found in the Summary of Lab Results section of this report.

AISLO appreciates the opportunity to perform these services for you and look forward to working with you on future projects. If you have any questions or comments regarding the information contained in this report or I can be of further assistance, please contact me by phone or email.

Sincerely,

Mike Bruffey  
Owner  
Asbestos Inspections SLO - AISLO  
CDPH Certified Lead Inspector Assessor – LRC-00003723

9517 Carmel Road, Atascadero, CA 93422 – (805) 235-0582 – bruffey@att.net

## PURPOSE AND SCOPE OF SERVICES

This survey and inspection involved collecting a limited number of paint/coating samples in various locations for lead, chromium, and cadmium content. The following is a detailed description of the work performed at this location.

1. For each sample, the following information was documented:
  - a) Sample Location
  - b) Sample Description
  - c) Condition of Material
  
2. Submission of samples to an EPA accredited lab for analysis that provides a report containing:
  - a) Sample identification number (AISLO)
  - b) Laboratory sample identification number
  - c) Analytical technique
  - d) Quality control procedures
  - e) The amount of Pb, Cr, and Cd in weight percent (mg/kg)
  
3. Analyze the laboratory sample results and produce a comprehensive written report that includes:
  - Applicable Definitions
  - Summary Report of Analysis
  - Conclusions and Recommendations
  - Limitations and Disclaimers
  - Metals Analysis of Paints – Laboratory Report
  - Analysis Request Form - Chain of Custody
  - Credentials – Inspector

## APPLICABLE DEFINITIONS

**Abatement** – any set of measures designed to reduce or eliminate lead hazards or lead-based paint for public and residential buildings but does not include containment or cleaning.

**Component** – a structural element or fixture, such as a wall, floor, ceiling, door, window, molding, trim, railing, cabinet, gutter, or downspout.

**Deteriorated Lead-Based Paint** – lead-based paint or presumed LBP that is cracking, chalking, flaking, chipping, peeling, non-intact, failed or otherwise separating from a component.

**Lead-Based Paint** – paint or other surface coatings that contain an amount of lead equal to or in excess of:

- (a) one milligram per square centimeter (1.0 mg/cm<sup>2</sup>)
- (b) half of one percent (.5%) by weight (5000 parts per million (ppm))

**Lead Hazard** – deteriorated lead-based paint, lead contaminated dust, lead contaminated soil, disturbing lead-based paint or presumed lead-based paint without containment, or any other nuisance which may result in persistent and quantifiable lead exposure.

**Lead-Related Construction Work** – any construction, alteration, painting, demolition, salvage, renovation, repair, or maintenance of any residential or public building, including preparation, and cleanup, that, by using or disturbing lead-containing material or soil, may result in significant exposure of adults or children to lead.

**Presumed Lead-Based Paint** – paint or surface coating affixed to a component in or on a structure constructed prior to January 1, 1978.

**Renovation, Repair and Painting Rule (RRP)** – requires that firms performing renovation, repair, and painting projects that disturb lead-based paint in homes, child care facilities and pre-schools built before 1978 have their firm certified by EPA, use certified renovators who are trained by EPA-approved training providers and follow lead-safe work practices.

## SUMMARY OF LAB RESULTS – CADMIUM, CHROMIUM, AND LEAD

A total of 2 samples were collected, documented, and sent to SGS Forensic Laboratories in Carson, CA to be analyzed for metals content using Method Reference EPA 3050B/6010B.

Sample#	Location	Description	Metal Content PPM
OCSD-1	Ring #1	Multi-layer coating - CADMIUM	6
OCSD-1	Ring #1	Multi-layer coating - CHROMIUM	26
OCSD-1	Ring #1	Multi-layer coating - LEAD	46
OCSD-2	Top of Tank	Multi-layer coating - CADMIUM	60
OCSD-2	Top of Tank	Multi-layer coating - CHROMIUM	18
OCSD-2	Top of Tank	Multi-layer coating - LEAD	410

As a comparison (for lead only), the EPA and CDPH consider a material to be lead-based paint when it exceeds .5% or 5,000 ppm. In addition, the Consumer Product Safety Commission (CPSC) set a limit of .009% or 90 ppm of lead in paint for children’s toys and Cal/OSHA regulates workers who disturb lead coated surfaces at any detectable lead level.



## CONCLUSIONS AND RECOMMENDATIONS

**Low levels of cadmium, chromium, and lead were detected in both samples analyzed by the lab.** The paint/coating was in poor condition and no lead hazards were noted. I recommend any contractor conducting work which will disturb painted surfaces receive proper notification of the metals content of the paint/coating surfaces prior to demolition or any activity which will disturb the material. All lead related work should be conducted in compliance with the Cal/OSHA (Title 8, Section 1532.1) and EPA regulations.

Precautions should also be taken even though low levels of cadmium and chromium were detected in the coating. For contractors removing any coatings, the PEL for cadmium and chromium ( $5 \mu\text{g}/\text{m}^3$ ), calculated as an eight-hour time-weighted average exposure (TWA) should not be exceeded. All work should be conducted in compliance with the Cal/OSHA (Title 8, Section 1532 and 1532.2 and EPA regulations. These sections can be found at <https://www.dir.ca.gov/title8/1532.html> and [https://www.dir.ca.gov/title8/1532\\_2.html](https://www.dir.ca.gov/title8/1532_2.html) Additional information about chromium can be found at <https://www.osha.gov/hexavalent-chromium>

## **LIMITATIONS AND DISCLAIMERS**

The findings and conclusions rendered in this report are opinions based on the scope of work authorized by the client and laboratory analysis of the tank surface coatings during this inspection. This report does not reflect variations which may exist between sampling points. These variations cannot be anticipated, nor could they be entirely accounted for, despite exhaustive additional testing. My work has been performed in accordance with generally accepted practices in the field of lead consultation.

Enclosed with this report are the following documents:

**Metals Analysis of Paints (Laboratory Report)**  
**Analysis Request Form (Chain of Custody)**  
**Credentials – Inspector**

# Metals Analysis of Bulks - TTLC

(AIHA-LAP, LLC Accreditation, Lab ID #101629)

Asbestos Inspections of SLO  
Mike Bruffey  
9517 Carmel Road

Atascadero, CA 93422

**Client ID:** L1985  
**Report Number:** M250250  
**Date Received:** 04/27/23  
**Date Analyzed:** 05/02/23  
**Date Printed:** 05/02/23  
**First Reported:** 05/02/23

**Job ID / Site:** Oceano Com. Service District Water Tank; 1935 19th Street, Oceano, Ca  
**Date(s) Collected:** 04/26/2023

**SGSFL Job ID:** L1985  
**Total Samples Submitted:** 2  
**Total Samples Analyzed:** 2

Sample Number	Lab Number	Analyte	Result	Result Units	Reporting Limit*	Method Reference
OCSD-1	LM248654	Cd	6	mg/kg	2	EPA 3050B/6010B
		Cr	26	mg/kg	2	EPA 3050B/6010B
		Pb	46	mg/kg	3	EPA 3050B/6010B
OCSD-2	LM248655	Cd	60	mg/kg	3	EPA 3050B/6010B
		Cr	18	mg/kg	2	EPA 3050B/6010B
		Pb	410	mg/kg	3	EPA 3050B/6010B

\* The Reporting Limit represents the lowest amount of analyte that the laboratory can confidently detect in the sample, and is not a regulatory level. The Units for the Reporting Limit are the same as the Units for the Final Results.

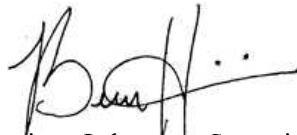

Beatriz Hinojosa, Laboratory Supervisor, Carson Laboratory

Analytical results and reports are generated by SGS Forensic Laboratories at the request of and for the exclusive use of the person or entity (client) named on such report. Results, reports or copies of same will not be released by SGS Forensic Laboratories to any third party without prior written request from client. This report applies only to the sample(s) tested. Supporting laboratory documentation is available upon request. This report must not be reproduced except in full, unless approved by SGS Forensic Laboratories. The client is solely responsible for the use and interpretation of test results and reports requested from SGS Forensic Laboratories. SGS Forensic Laboratories is not able to assess the degree of hazard resulting from materials analyzed. SGS Forensic Laboratories reserves the right to dispose of all samples after a period of thirty (30) days, according to all state and federal guidelines, unless otherwise specified. Any modifications that have been made to referenced test methods are documented in SGS Forensic Laboratories' Standard Operating Procedures Manual. Sample results have not been blank corrected. Quality control and sample receipt condition were acceptable unless otherwise noted.

Note\* Sampling data used in this report was provided by the client as noted on the associated chain of custody form.

Client Name & Address: Asbestos Inspections of SLO 9517 Carmel Road Atascadero, CA 93422		Client No.: L1985	PO / Job#:	Date: 4-26-23
Contact: Mike Bruffey		Phone: (805) 235-0582	Turn Around Time: Same Day / 1Day / 2Day / <del>3Day</del> / 4Day / 5Day	
E-mail: bruffey@att.net		<input type="checkbox"/> PCM: <input type="checkbox"/> NIOSH 7400A / <input type="checkbox"/> NIOSH 7400B <input type="checkbox"/> Rotometer <input type="checkbox"/> PLM: <input type="checkbox"/> Standard / <input type="checkbox"/> Point Count 400 - 1000 / <input type="checkbox"/> CARB 435		
Site Name: Oceano Com. Service District Water Tank		<input type="checkbox"/> TEM Air: <input type="checkbox"/> AHERA / <input type="checkbox"/> Yamate2 / <input type="checkbox"/> NIOSH 7402 <input type="checkbox"/> TEM Bulk: <input type="checkbox"/> Quantitative / <input type="checkbox"/> Qualitative / <input type="checkbox"/> Chatfield <input type="checkbox"/> TEM Water: <input type="checkbox"/> Potable / <input type="checkbox"/> Non-Potable / <input type="checkbox"/> Weight % <input type="checkbox"/> TEM Microvac: <input type="checkbox"/> Qual / <input type="checkbox"/> D5755(str/area) / <input type="checkbox"/> D5756(str/mass)		
Site Location: 1935 19th Street, Oceano, CA		<input type="checkbox"/> IAQ Particle Identification (PLM LAB) <input type="checkbox"/> PLM Opaques/Soot <input type="checkbox"/> Particle Identification (TEM LAB) <input type="checkbox"/> Special Project <input checked="" type="checkbox"/> Metals Analysis Matrix: Paint Method: ICP Analytes: LEAD & CHROMIUM & CADMIUM		
Comments: Email results to: bruffey@att.net			<input type="checkbox"/> Silica in Air <input type="checkbox"/> w/Gravimetry <input type="checkbox"/> Quartz Only	

Sample ID	Date / Time	Sample Location / Description	FOR AIR SAMPLES ONLY				Sample Area / Air Volume
			Type	Time On/Off	Avg LPM	Total Time	
OCSD-1	4-26-23 7:30	North side Ring 1/Blue/green/beige paint	A P C				
OCSD-2	↓	Tank Top/Blue/green paint	A P C				
			A P C				
			A P C				
			A P C				
			A P C				
			A P C				
			A P C				
			A P C				
			A P C				
			A P C				
			A P C				

Sampled By: Mike Bruffey	Date/Time: 4-26-23	Shipped Via: <input checked="" type="checkbox"/> Fed Ex <input type="checkbox"/> UPS <input type="checkbox"/> US Mail <input type="checkbox"/> Courier <input type="checkbox"/> Drop Off <input type="checkbox"/> Other:	
Relinquished By: Mike Bruffey <i>MB</i>	Date / Time: 4-26-23 @ 2:30	Relinquished By:	Relinquished By:
Received By: <i>Jaime Contreras</i>	Date / Time: 4-27-23 / 9:25 AM	Received By:	Received By:
Condition Acceptable? <input type="checkbox"/> Yes <input type="checkbox"/> No	Condition Acceptable? <input type="checkbox"/> Yes <input type="checkbox"/> No	Condition Acceptable? <input type="checkbox"/> Yes <input type="checkbox"/> No	Condition Acceptable? <input type="checkbox"/> Yes <input type="checkbox"/> No

SGS Forensic Laboratories may subcontract client samples to other SGSFL locations to meet client requests.  
 San Francisco Office: 3777 Depot Road, Suite 409, Hayward, CA 94545-2761 • Phone: 510/887-8828 • 800/827-3274  
 Los Angeles Office: 20535 South Belshaw Ave., Carson, CA 90746 • Phone: 310/763-2374 • 888/813-9417  
 Las Vegas Office: 6765 S. Eastern Avenue, Suite 3, Las Vegas, NV 89119 • Phone: 702/784-0040



# LEAD-RELATED CONSTRUCTION CERTIFICATE

**INDIVIDUAL:**



**Michael Bruffey**

**CERTIFICATE TYPE:**

Lead Inspector/Assessor

**NUMBER:**

LRC-00003723

**EXPIRATION DATE:**

12/19/2023

Disclaimer: This document alone should not be relied upon to confirm certification status. Compare the individual's photo and name to another valid form of government issued photo identification. Verify the individual's certification status by searching for Lead-Related Construction Professionals at [www.cdph.ca.gov/programs/clppb](http://www.cdph.ca.gov/programs/clppb) or calling (800) 597-LEAD

## **APPENDIX B**

### **PROJECT DRAWINGS**

# OCEANO COMMUNITY SERVICES DISTRICT PLANS FOR THE CONSTRUCTION OF THE WATER STORAGE TANK REHABILITATION PROJECT



## DRAWING TABLE OF CONTENTS

1. COVER SHEET
2. VICINITY AND LOCATION MAPS
3. NOTES
4. NOTES
5. TANK PLAN
6. ROOF STRUCTURE
7. ROOF VENT AND ROOF HATCH DETAILS
8. SPIRAL STAIRS
9. STAIR CAGE





ADVANTAGE TECHNICAL SERVICES, INC.  
805-595-2282  
ATS-SLO.COM

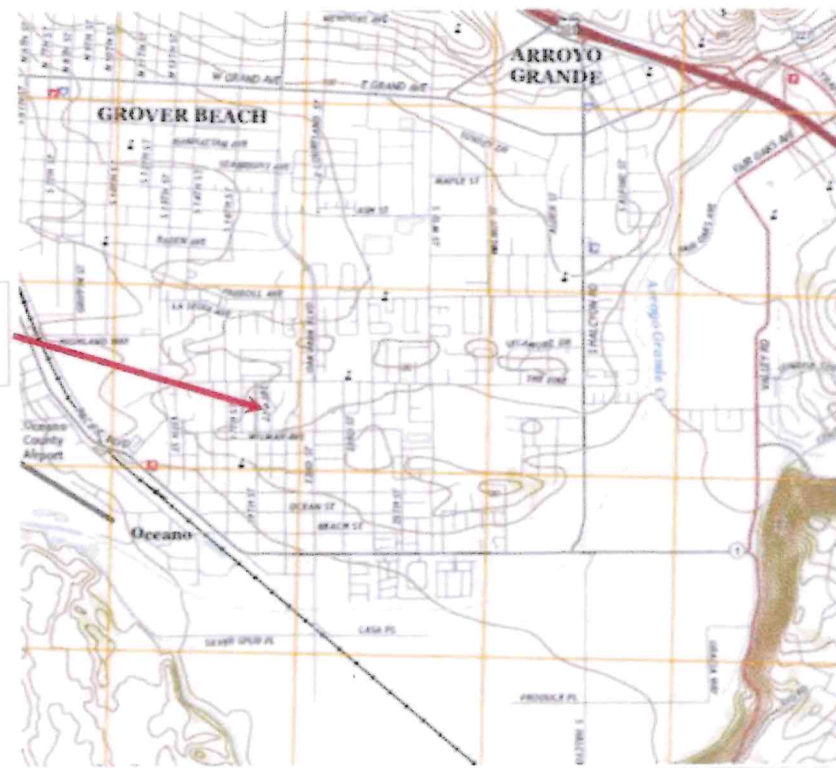

PROJECT SITE



Copyright © 2023 Advantage Technical Services, a California Corporation. All rights reserved

REVISIONS	DATE	 <b>ADVANTAGE TECHNICAL SERVICES, INC</b> 805-595-2282 ATS-SLO.COM	DESIGNED BY:	DRAWN BY:	CHECKED BY:	RECOMMENDED:		<b>OCEANO COMMUNITY SERVICES DISTRICT</b> <b>WATER STORAGE TANK REHABILITATION</b>	SHEET:
	00/00/00		WB	DC	JB	<i>Tony Marraccino</i> TONY MARRACCINO - UTILITY SYSTEMS MANAGER			2 OF 9
			PREPARED UNDER THE DIRECTION OF:		7/28/2023	APPROVED:		<b>VICINITY AND LOCATION MAPS</b>	SCALE:
			<i>William Bellis</i> WILLIAM BELLIS P.E.		DATE	<i>Will Clemens</i> WILL CLEMENS - GENERAL MANAGER			VARIES





# ASCE 7 Hazards Report

Address: Oceano California,

Standard: ASCE/SEI 7-22  
Risk Category: IV  
Soil Class: Default  
Latitude: 35.09884  
Longitude: -120.61248  
Elevation: 22.58911449253668 ft (NAVD 88)

Seismic Default

### Site Soil Class:

#### Results:

PGA <sub>M</sub> :	0.54	T <sub>L</sub> :	8
S <sub>MS</sub> :	1.37	S <sub>s</sub> :	1.15
S <sub>M1</sub> :	0.93	S <sub>1</sub> :	0.37
S <sub>DS</sub> :	0.92	V <sub>S30</sub> :	260
S <sub>D1</sub> :	0.62		

Seismic Design Category: D

### STATEMENT OF SPECIAL INSPECTIONS

THE OWNER SHALL EMPLOY THE SERVICES OF A REGISTERED PROFESSIONAL ENGINEER TO PROVIDE STRUCTURAL OBSERVATIONS AS DEFINED IN SECTION 1702 OF THE CALIFORNIA BUILDING CODE. THE STRUCTURAL OBSERVER SHALL PROVIDE OBSERVATION OF ERECTION PRACTICES DURING THE FOLLOWING PROCESSES:

- FIELD WELDING OF WELDING - TWO SITE VISITS MINIMUM

### SCHEDULE OF INSPECTION, TESTING AGENCIES AND INSPECTORS

THE FOLLOWING ARE THE TESTING AGENCIES AND SPECIAL INSPECTORS THAT WILL BE RETAINED TO CONDUCT TESTS AND INSPECTIONS ON THIS PROJECT:

SPECIAL INSPECTION FOR WELDING  
ADVANTAGE TECHNICAL SERVICES, INC  
6661 FERN CANYON RD.  
SAN LUIS OBISPO, CA



COUNTY OF SAN LUIS OBISPO  
DEPARTMENT OF PLANNING & BUILDING  
Statement Of Required Special Inspections

BLD-1032  
08/02/2019

The Statement Of Required Special Inspections *imprinted on the plan sheet shall be unique to the specific project identifying only the inspections as required.*

Project Address: 1935 Wilmar (physically on 19th st.) Permit No.:

Notation Used In Table:

Column headers:

- C Indicates continuous inspection is required.
- P Indicates periodic inspections are required. The notes and or contract documents should clarify.

Notes Applicable standards as referenced from the California Building Code

Box entries:

- X Is placed in the appropriate column to denote either "C" continuous or "P" periodic inspections.
- Denotes an activity that is either a one-time activity or one whose frequency is defined in some other manner.
- Selection box of required special inspections identified with an X by design professional.

Additional detail regarding inspections and tests are provided in the project specification or notes on the drawings.

Verification and Inspection	C	P	Notes
<input checked="" type="checkbox"/> 1704.2.5 - Inspect fabricator's fabrication and quality control procedures.			
<input type="checkbox"/> 1704.2.5.1 - Certificate of Compliance from Approved Fabricator			

### Statement Of Required Special Inspections

Verification and Inspection	C	P	Notes
<input type="checkbox"/> 1) Complete penetration groove welds 5/16" or greater in risk category III or IV.		---	UT on 100%, may reduce to 25% per AISC 360, N5e
<input type="checkbox"/> 2) Complete penetration groove welds 5/16" or greater in risk category II.		---	UT on 10%, may increase to 100% per AISC 360, N5f
<input type="checkbox"/> 3) Thermally cut surfaces of access holes when material t > 2".		---	
<input type="checkbox"/> 4) Welded joints subject to fatigue when required by AISC 360, Appendix 3, Table A-3.1.		---	
<input type="checkbox"/> 5) Fabricator's NDT reports when fabricator performs NDT.		---	AISC 360, N5d
<input type="checkbox"/> 5. Structural steel bolting:			
<input type="checkbox"/> a. Inspection tasks Prior to Bolting (Observe, or perform tasks for each bolted connection in accordance with QA tasks listed in AISC 360, Table N5.6-1.)		---	
<input type="checkbox"/> b. Inspection tasks During Bolting (Observe the QA tasks listed in AISC 360, Table N5.6-2.)		---	
<input type="checkbox"/> c. Inspection tasks After Bolting (Perform tasks for each bolted connection in accordance with QA tasks listed in AISC 360, Table N5.6-3.)		---	
<input type="checkbox"/> 6. Inspection of steel elements of composite construction prior to concrete placement in accordance with QA tasks listed in AISC 360, Table N6.1.		---	

### Statement Of Required Special Inspections

BLD-1032  
08/02/2019

Verification and Inspection	C	P	Notes
<input checked="" type="checkbox"/> Table 1705.2 - Structural Steel (AISC 360 and AISC 341)			
<input checked="" type="checkbox"/> 1. Fabricator and erector documents (Verify reports and certificates as listed in AISC, chapter N, paragraph N, paragraph 3.2 for compliance with construction documents.)			
<input checked="" type="checkbox"/> 2. Material verification of structural steel.		X	
<input checked="" type="checkbox"/> 3. Verify member locations, braces, stiffeners, and application of joint details at each connection comply with construction documents.		X	
<input checked="" type="checkbox"/> 4. Structural steel welding:			
<input type="checkbox"/> a. Inspection tasks Prior to Welding (Observe, or perform for each welded joint or member, the QA tasks listed in AISC 360, Table N5.4-1.)		---	
<input checked="" type="checkbox"/> b. Inspection tasks During Welding (Observe, or perform for each welded joint or member, the QA tasks listed in AISC 360, Table N5.4-2.)		---	
<input checked="" type="checkbox"/> c. Inspection tasks After Welding (Observe, or perform for each welded joint or member, the QA tasks listed in AISC 360, Table N5.4-3.)		---	
<input type="checkbox"/> d. Nondestructive testing (NDT) of welded joints:			EXCEPTION: NDT of welds completed in an approved fabricator's shop. See AISC 360, N7

### Statement Of Required Special Inspections

Verification and Inspection	C	P	Notes
<input type="checkbox"/> Table 1705.2.2 - Verification of Steel Construction Other Than Structural Steel			
<input type="checkbox"/> 1. Material verification of cold-formed steel deck:			
<input type="checkbox"/> a. Identification markings to conform to ASTM standards specified in the approved construction documents.		X	Applicable ASTM material standards.
<input type="checkbox"/> b. Manufacturer's certified test reports.		X	
<input type="checkbox"/> 2. Inspection of welding:			
<input type="checkbox"/> a. Cold-formed steel deck:			
<input type="checkbox"/> 1) Floor and roof deck welds.		X	AWS D1.3
<input type="checkbox"/> b. Reinforcing steel:			
<input type="checkbox"/> 1) Verification of weldability of reinforcing steel other than ASTM A 706.		X	AWS D1.4, ACI 318: Section 3.5.2
<input type="checkbox"/> 2) Reinforcing steel resisting flexural and axial forces in intermediate and special moment frames, and boundary elements of special structural walls of concrete and shear reinforcement.		X	AWS D1.4, ACI 318: Section 3.5.2
<input type="checkbox"/> 3) Shear reinforcement.		X	AWS D1.4, ACI 318: Section 3.5.2
<input type="checkbox"/> 4) Other reinforcing steel.		X	AWS D1.4, ACI 318: Section 3.5.2

Copyright © 2023 Advantage Technical Services, a California Corporation. All rights reserved

REVISIONS	DATE		DESIGNED BY:	DRAWN BY:	CHECKED BY:	RECOMMENDED:		OCEANO COMMUNITY SERVICES DISTRICT WATER STORAGE TANK REHABILITATION	SHEET:
	00/00/00		WB	DC	JB				3 OF 9
		ADVANTAGE TECHNICAL SERVICES, INC 805-595-2262 ATS-SLO.COM	PREPARED UNDER THE DIRECTION OF:		7/28/2023	APPROVED:		NOTES	SCALE:
			WILLIAM BELLIS P.E.		DATE	WILL CLEMENS - GENERAL MANAGER			VARIES

**SITE SAFETY AND ENVIRONMENTAL CONTROLS**

**ABBREVIATIONS**

1.01 Noise

- A. Noise generated from equipment operating overnight including generators, pumps and dehumidification shall not exceed 75 dB at all property lines.
- B. Construction activities shall be restricted to the hours of 7:00AM to 5:00PM Monday through Friday. No construction shall occur on Saturday or Sunday. On-site equipment maintenance and servicing shall be confined to the same hours.
- C. All construction equipment utilizing internal combustion engines shall be required to have mufflers that are in good condition and tuned according to the manufacture's recommendations. Stationary noise sources shall utilize noise reducing engine housing enclosures or noise screens.

1.02 OSHA Compliance.

- A. Contractor shall comply with all applicable regulations including state and federal OSHA and these Special Provisions.
- B. Contractor is responsible for complying with Cal/OSHA regulations for lead in construction in accordance with California Code of Regulations, California Title 8, Section 1532.1.
- C. The costs for complying with all OSHA requirements shall be considered as included in the various contract prices paid and no additional compensation will be allowed. Contractors are encouraged to take lead samples in advance by arrangement with the owner.

1.03 Housekeeping and Cleanup

- A. At the end of each work day, dust and abrasive shall be removed from the surfaces and surrounding areas. Spent abrasive shall be stored in temporary storage containers on site pursuant to Best Management Practices and Best Pollution Prevention Practices listed under federal and state guidelines.
- B. The site shall be maintained free of unnecessary accumulations of tools, equipment, surplus materials, and debris. Equipment maintenance and spill prevention procedures shall be adequate to prevent spills and leaks.
- C. Upon completion of the work, the Contractor shall remove all excess materials, equipment, containers, and waste from the job site. Coating spots or stains shall be removed from adjacent surfaces and surfaces repaired if needed. As work proceeds, promptly remove all coating that is spilled, splashed, or splattered. Collect empty containers, rags, waste material, and debris and store or remove from the site as appropriate.



1.04 Access, Containment and Protection

- A. The Contractor shall provide scaffolding or other access and fall protection anchors to allow safe access for Contractor personnel, inspection personnel and others as appropriate
- B. The tank is situated near residences. All surface drains and swales lead directly onto the adjacent land, or to creeks and the ocean. Contractor shall protect all work sites and all drainage inlets from pollutants and illegal discharges.
- C. The work will be conducted in and around operational equipment and adjacent to residences. The Contractor shall provide containment or mitigation of air-borne dust, overspray and other contaminants to protect the existing equipment, facilities and neighboring properties from dust, overspray pursuant to regulatory requirements.

- AB ANCHOR BOLT
- AC ASPHALTIC CONCRETE
- ACI AMERICAN CONCRETE INSTITUTE
- AL ALUMINUM
- ASTM AMERICAN SOCIETY FOR TESTING AND MATERIALS
- AWS AMERICAN WELDING SOCIETY
- BFV BUTTERFLY VALVE
- BLDG BUILDING
- BM BEAM
- BRG BEARING
- CB CATCH BASIN
- CFM CUBIC FEET PER MINUTE
- CJ CONSTRUCTION JOINT
- CL CENTER LINE
- CLR CLEARANCE
- CMLSP CEMENT MORTAR LINED STEEL PIPE
- CMU CONCRETE MASONRY UNIT
- COL COLUMN
- CONC CONCRETE
- CONN CONNECTION
- CONT CONTINUOUS
- CORP CORPORATION
- CP CATHODIC PROTECTION
- CTR CENTER
- CU FT CUBIC FOOT
- CU IN CUBIC INCH
- CU YD CUBIC YARD
- CV CHECK VALVE
- DIA DIAMETER
- DR DRAIN
- DWG DRAWING
- E EXISTING
- EA EACH
- EL ELEVATION
- ELB, ELLELBOW
- ENGR ENGINEER
- EQL SP EQUALLY SPACED
- EXP JT EXPANSION JOINT
- EXST EXISTING
- F FEMALE
- FB FLAT BAR
- FCO FLUSH CLEAN OUT
- FD FLOOR DRAIN

- FG FINISHED GRADE
- FRP FIBER REINFORCED PLASTIC
- FTG FOOTING
- GPM GALLONS PER MINUTE
- HDG HOT DIP GALVINIZED
- HORIZ HORIZONTAL
- HSS HOLLOW STRUCTURAL STEEL
- I.F. INSIDE FACE
- I/O INLET OUTLET
- IN. INCH
- INV INVERT
- JT JOINT
- LG LEVEL GAGE
- LONG. LONGITUDINAL
- M MALE
- MAX MAXIMUM
- MFR MANUFACTURER
- MIN MINIMUM
- MISC MISCELLANEOUS
- MJ MECHANICAL JOINT
- MPH MILES PER HOUR
- MW MANWAY
- N NEW
- NPT NOMINAL PIPE THREAD
- NTS NOT TO SCALE
- OC ON CENTER
- OD OUTSIDE DIAMETER
- OF OVERFLOW
- PLYWD PLYWOOD
- PRCST PRECAST
- PREFAB PREFABRICATED
- PSF POUNDS PER SQUARE FOOT
- PSI POUNDS PER SQUARE INCH
- PSIG POUNDS PER SQUARE INCH GAUGE
- PT POINT OF TANGENCY
- PVC POLYVINYL CHLORIDE PLASTIC
- RC REINFORCED CONCRETE
- RD ROAD, ROOF DRAIN
- REINF REINFORCED, REINFORCING
- RH ROOF HATCH
- RST REINFORCING STEEL
- RV ROOF VENT
- UBC UNIFORM BUILDING CODE

- UD UNDERDRAIN
- UG UNDERGROUND
- VAC VACUU
- VERT VERTICAL
- WS WATERSTOP
- WTR WATER
- WWF WELDED WIRE FABRIC

REVISIONS	DATE	 ADVANTAGE TECHNICAL SERVICES, INC 805-595-2282 ATS-SLO.COM	DESIGNED BY:	DRAWN BY:	CHECKED BY:	RECOMMENDED:		OCEANO COMMUNITY SERVICES DISTRICT WATER STORAGE TANK REHABILITATION	SHEET:
	00/00/00		WB	DC	JB	<i>Anthony M. Marraccino</i> TONY MARRACCINO - UTILITY SYSTEMS MANAGER		4 OF 9	
			PREPARED UNDER THE DIRECTION OF:	7/28/2023	APPROVED:		NOTES	SCALE:	
			WILLIAM BELLIS P.E.	DATE	<i>William Clemens</i> WILL CLEMENS - GENERAL MANAGER			VARIABLES	



# DRAWING NOTES

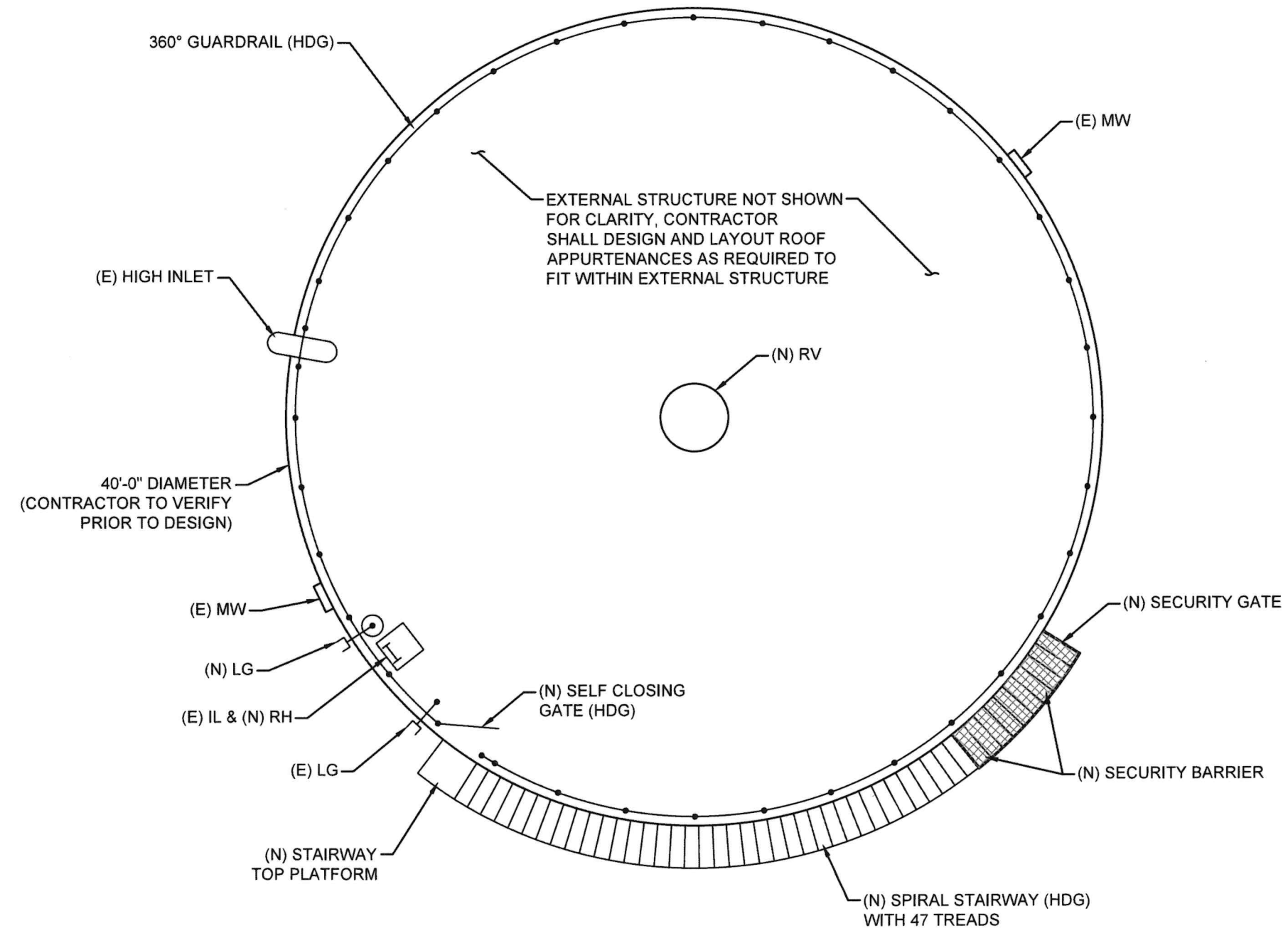

1. PRIOR TO THE START OF CONSTRUCTION, OWNER STAFF SHALL EMPTY THE TANK. THE TANK WILL BE OUT OF SERVICE AND DRAINED BUT SOME WATER WILL REMAIN. THE CONTRACTOR SHALL REMOVE THE REMAINING WATER AS NEEDED TO FACILITATE THE START OF WORK.
2. PROVIDE NEW APPURTENANCES PURSUANT TO THE PROJECT DRAWINGS AND SPECIFICATIONS.
3. FINAL LOCATIONS FOR TANK ROOF APPURTENANCES SHALL BE COORDINATED W/ THE OWNER'S REPRESENTATIVE.
4. LEVEL GAUGE SHALL BE MOVED TO THE NEW LOCATION SHOWN. A PVC PIPE STILLING WELL SHALL BE PROVIDED TO GUIDE THE FLOAT AND PROTECT GAUGE CABLE FROM WAVE ACTION ASSOCIATED WITH THE HIGH INLET.
5. THE HIGH INLET SHALL BE DISCONNECTED FROM THE EXISTING ROOF AND RE-MOUNTED TO THE NEW ROOF.
6. NEW GUARDRAIL AND SELF CLOSING SWING GATE SHALL PROVIDE PROTECTION AT THE ENTIRE ROOF PERIMETER. GUARDRAIL SHALL HAVE TOEBOARD AND TWO INTERMEDIATE RAILS. GUARDRAIL AND SWING GATE SHALL BE HOT DIP GALVANIZED.
7. REMOVE AND DISPOSE OF CATHODIC PROTECTION SYSTEM INCLUDING POST AND RECTIFIER ENCLOSURE. DISCONNECT AT CIRCUIT BREAKER. CUT CONDUIT AND CAP AT 1'-0" UNDERGROUND. CONDUIT MAY BE ABANDONED IN PLACE.



## TANK PLAN



Copyright © 2023 Advantage Technical Services, a California Corporation. All rights reserved

REVISIONS	DATE	 <b>ADVANTAGE TECHNICAL SERVICES, INC.</b> 805-595-2282 ATS-SLO.COM	DESIGNED BY:	DRAWN BY:	CHECKED BY:	RECOMMENDED:		OCEANO COMMUNITY SERVICES DISTRICT	SHEET:
	00/00/00		WB	DC	JB	<i>Tony Marraccino</i> TONY MARRACCINO - UTILITY SYSTEMS MANAGER		WATER STORAGE TANK REHABILITATION	5 OF 9
			PREPARED UNDER THE DIRECTION OF:		7/28/2023	APPROVED:		TANK PLAN	SCALE:
			WILLIAM BELLIS P.E.		DATE	<i>Will Clemens</i> WILL CLEMENS - GENERAL MANAGER			VARIES

# DRAWING NOTES

1. REMOVE AND RECYCLE EXISTING ROOF PLATE, RAFTERS, RAFTER CLIPS, CENTER SUPPORT AND BASE PLATES.
2. NEW ROOF SHALL BE DESIGNED AND CONSTRUCTED WITH INTEGRAL FORMED CHANNEL "RAFTERS" ON THE EXTERIOR.
3. ALL AREAS ON THE INTERIOR AND EXTERIOR, THAT ARE INACCESSIBLE FOR COATING SHALL BE SEAL WELDED.
4. THE ROOF DESIGN SHALL PROVIDE A SYSTEM FOR CONTROL OF SHELL ROUNDNESS DURING ERECTION SUCH AS ERECTION BOLTS OR OTHER METHOD USING POSITIVE STOPS.
5. ROOF SECTIONS SHALL NOT BE PRIME COATED UNTIL AFTER FORMING.
6. ALL PLATE EDGES SHALL BE FINISHED TO A MINIMUM OF 1/16" RADIUS PRIOR TO ABRASIVE PREPARATION.

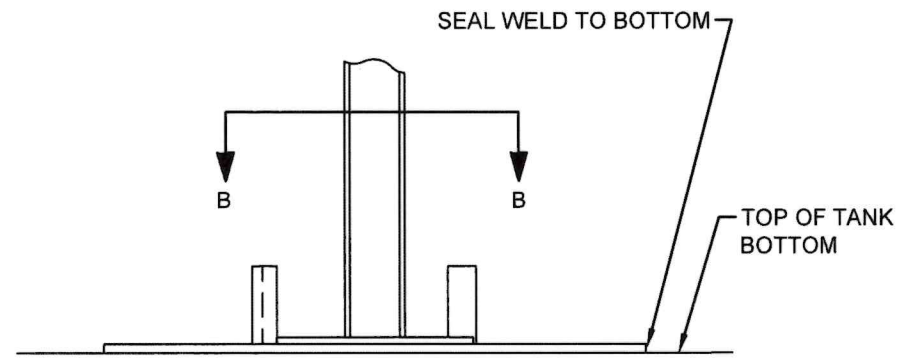

(BASE PLATE THICKNESS AND DIMENSIONS BY CONTRACTOR'S ENGINEER)

## FLOATING BASE PLATE DETAIL

SCALE: 1/2" = 1'-0"

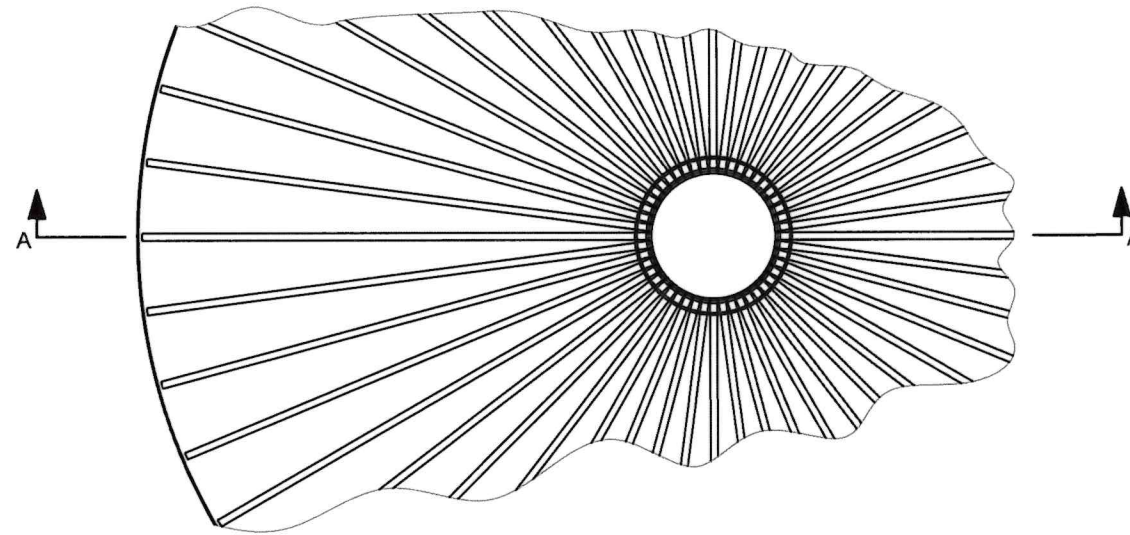

## TANK STRUCTURE PARTIAL PLAN

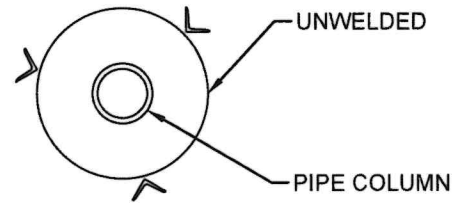

## SECTION VIEW B-B

SCALE: 1/2" = 1'-0"

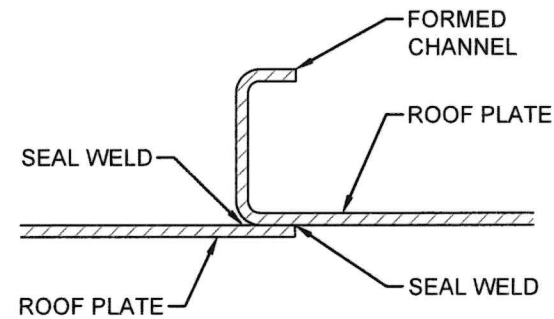

## SECTION VIEW C-C

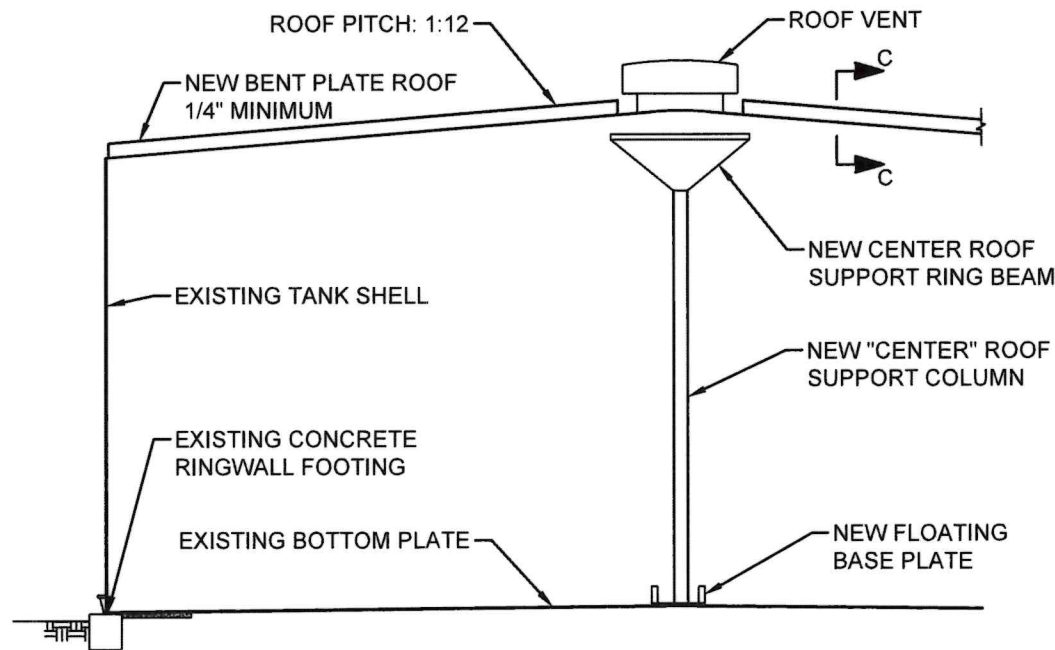

SCALE: 3" = 1'-0"



## PARTIAL SECTION VIEW A-A

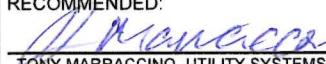

Copyright © 2023 Advantage Technical Services, a California Corporation. All rights reserved

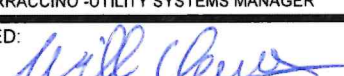
<table border="1"> <thead> <tr> <th>REVISIONS</th> <th>DATE</th> </tr> </thead> <tbody> <tr> <td> </td> <td>00/00/00</td> </tr> <tr> <td> </td> <td> </td> </tr> <tr> <td> </td> <td> </td> </tr> <tr> <td> </td> <td> </td> </tr> </tbody> </table>	REVISIONS	DATE		00/00/00							 <b>ADVANTAGE TECHNICAL SERVICES, INC.</b> 805-595-2282 ATS-SLO.COM	DESIGNED BY: WB	DRAWN BY: DC	CHECKED BY: JB	RECOMMENDED:  TONY MARRACCINO - UTILITY SYSTEMS MANAGER		OCEANO COMMUNITY SERVICES DISTRICT WATER STORAGE TANK REHABILITATION	SHEET: 6 OF 9
	REVISIONS	DATE																
	00/00/00																	
PREPARED UNDER THE DIRECTION OF:  WILLIAM BELLIS P.E.	DATE: 7/28/2023	APPROVED:  WILL CLEMENS - GENERAL MANAGER	ROOF STRUCTURE	SCALE: VARIES														

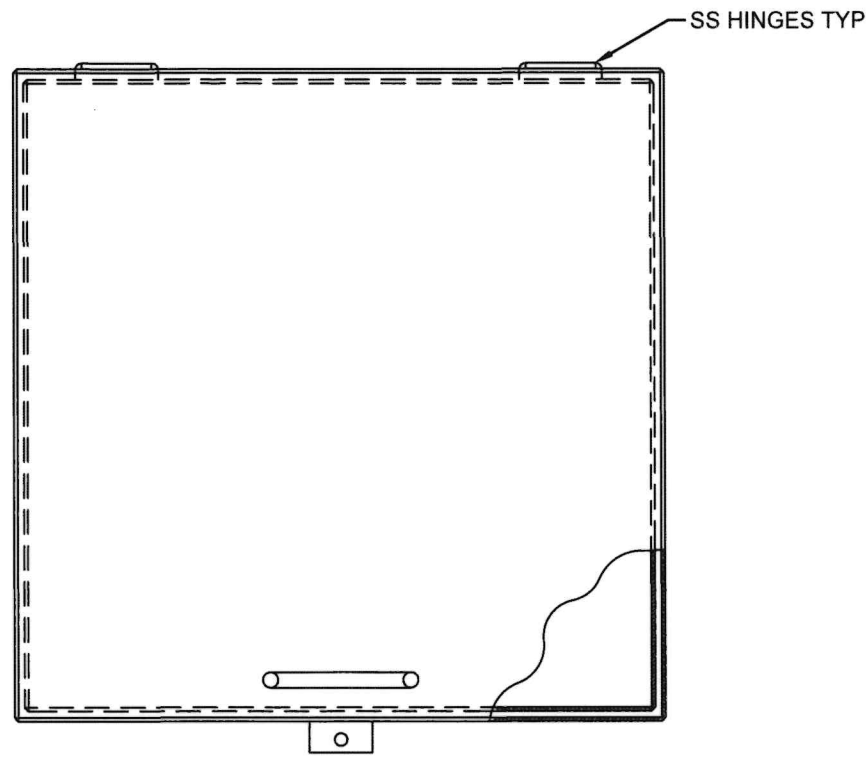

TOP VIEW

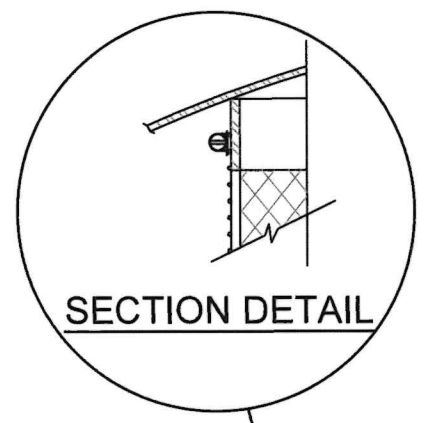

SECTION DETAIL

NOTE:  
INSTALL CLAMPING RINGS AFTER SCREEN IS IN PLACE. RINGS  
& SCREEN ARE TO BE INSTALLED AFTER ALL PAINT IS CURED.

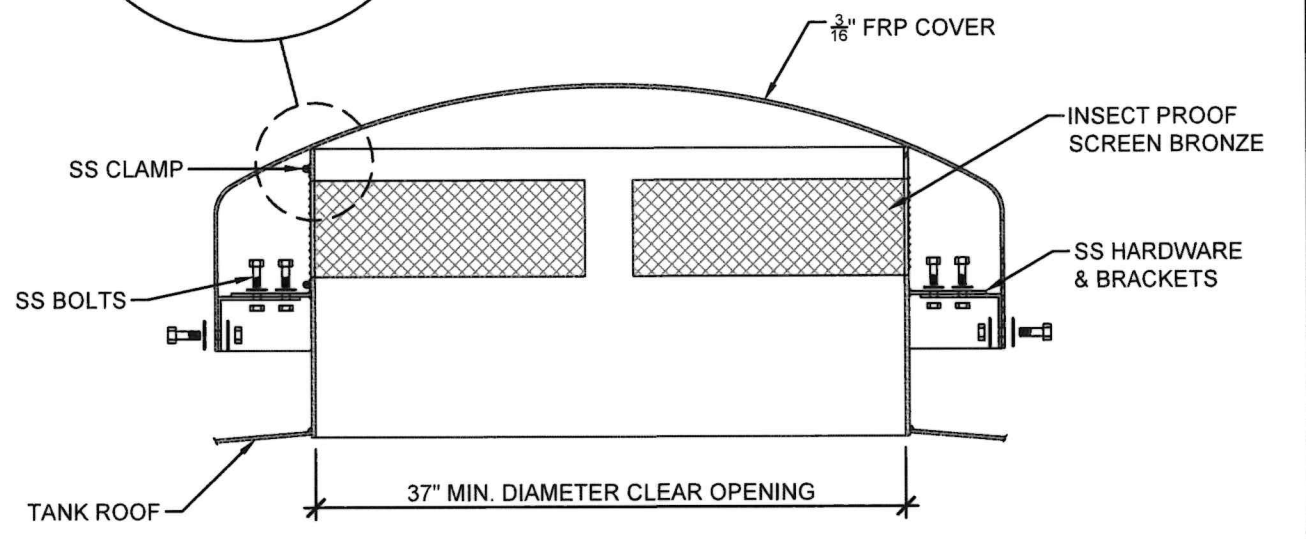

ROOF VENT SECTION

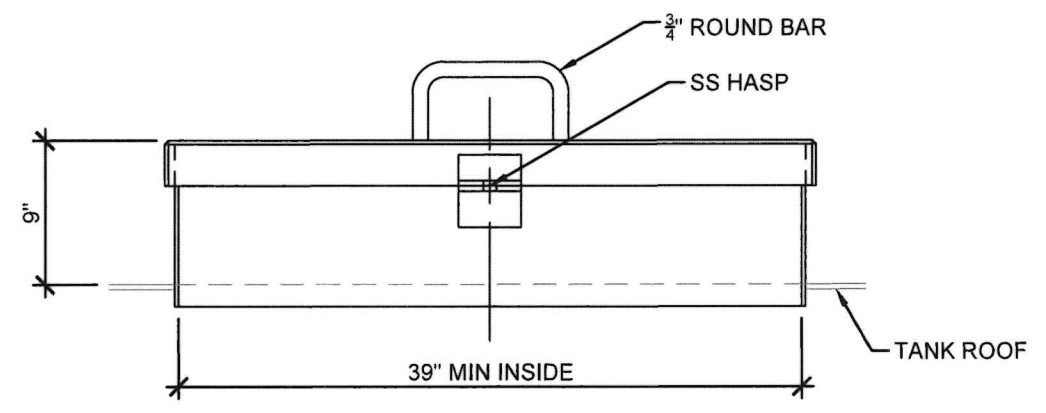

FRONT VIEW

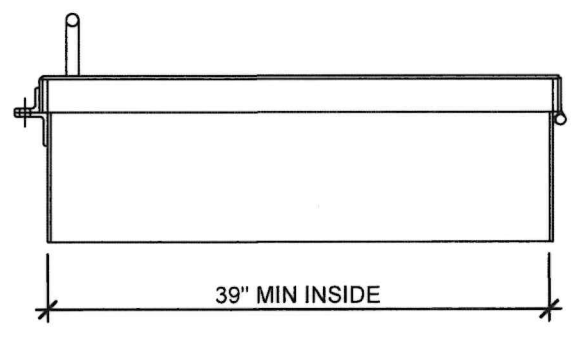



SIDE VIEW

ROOF HATCH



Copyright © 2023 Advantage Technical Services, a California Corporation. All rights reserved

REVISIONS DATE 00/00/00	 ADVANTAGE TECHNICAL SERVICES, INC. 805-595-2282 ATS-SLO.COM	DESIGNED BY: WB	DRAWN BY: DC	CHECKED BY: JB	RECOMMENDED:  TONY MARRACCINO - UTILITY SYSTEMS MANAGER		OCEANO COMMUNITY SERVICES DISTRICT WATER STORAGE TANK REHABILITATION	SHEET: 7 OF 9
		PREPARED UNDER THE DIRECTION OF:  WILLIAM BELLIS P.E.		7/28/2023 DATE	APPROVED:  WILL CLEMENS - GENERAL MANAGER		ROOF VENT AND ROOF HATCH DETAILS	SCALE: VARIES

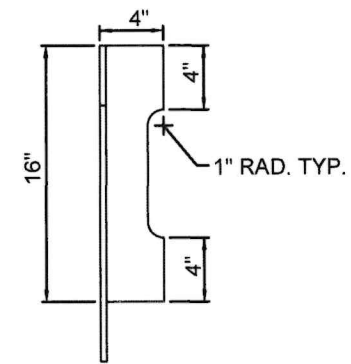

VIEW A-A

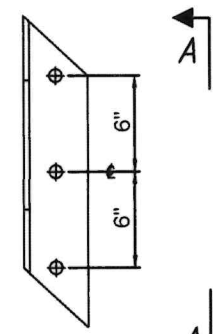

CLIP DETAIL

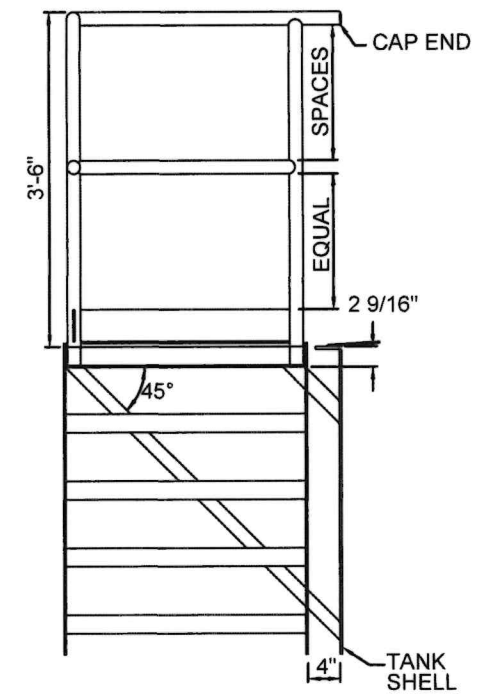
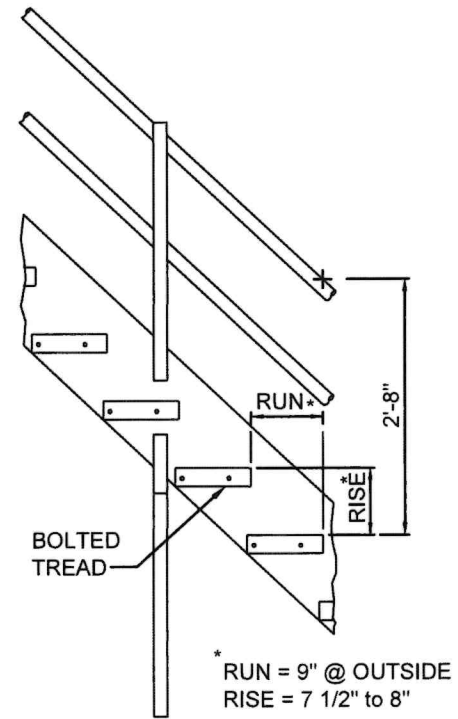
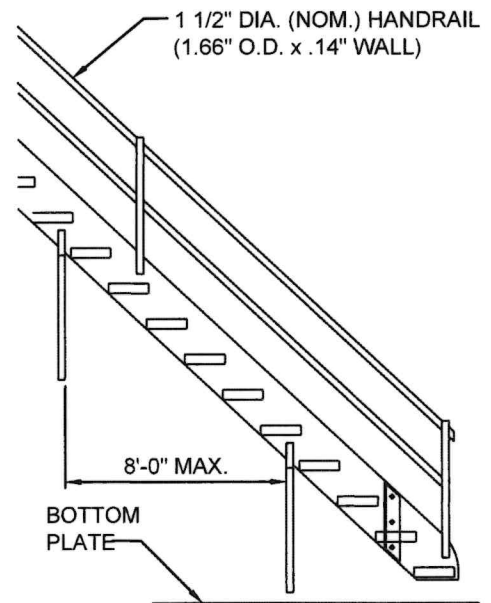
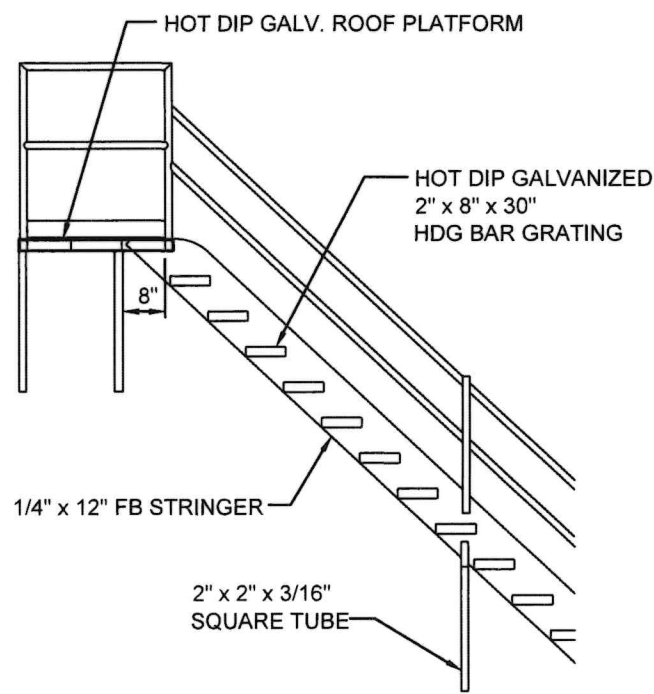





### SPIRAL STAIR ELEVATIONS

SCALE: 1/2" = 1'-0"



Copyright © 2023 Advantage Technical Services, a California Corporation. All rights reserved

REVISIONS DATE 00/00/00	 <b>ADVANTAGE TECHNICAL SERVICES, INC.</b> 805-595-2282 ATS-SLO.COM	DESIGNED BY: <b>WB</b>	DRAWN BY: <b>DC</b>	CHECKED BY: <b>JB</b>	RECOMMENDED:  TONY MARRACCINO - UTILITY SYSTEMS MANAGER		OCEANO COMMUNITY SERVICES DISTRICT WATER STORAGE TANK REHABILITATION	SHEET: 8 OF 9
		PREPARED UNDER THE DIRECTION OF:  WILLIAM BELLIS P.E.		DATE: 7/28/2023	APPROVED:  WILL CLEMENS - GENERAL MANAGER			SCALE: VARIES

HOT DIP GALVANIZE  
ALL PARTS AFTER  
FABRICATION

ATTACH EXPANDED METAL AND  
ANGLE TOP AND BOTTOM WITH  
FENDER WASHERS AND RIVETS  
(ITEMS 4 & 5) AT 2'-0" MAX SPACING

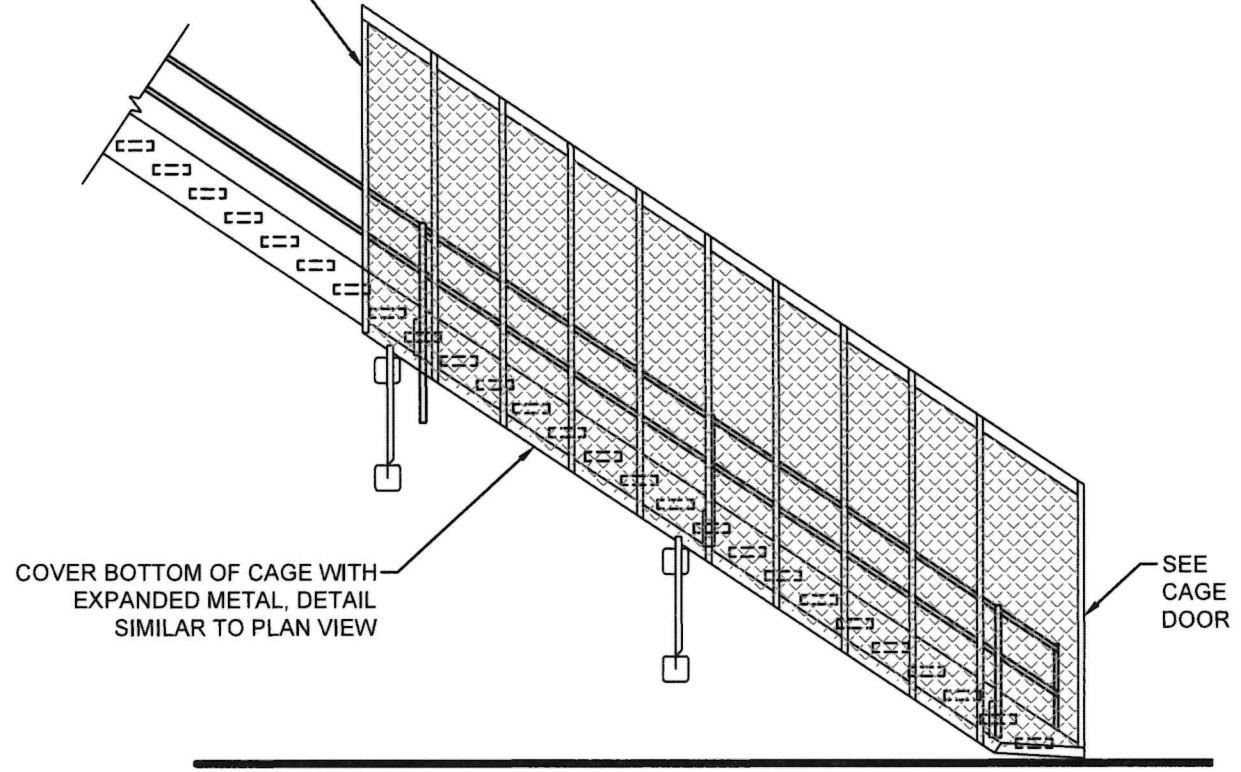

**STAIR CAGE**  
SCALE: 3/16" = 1'-0"

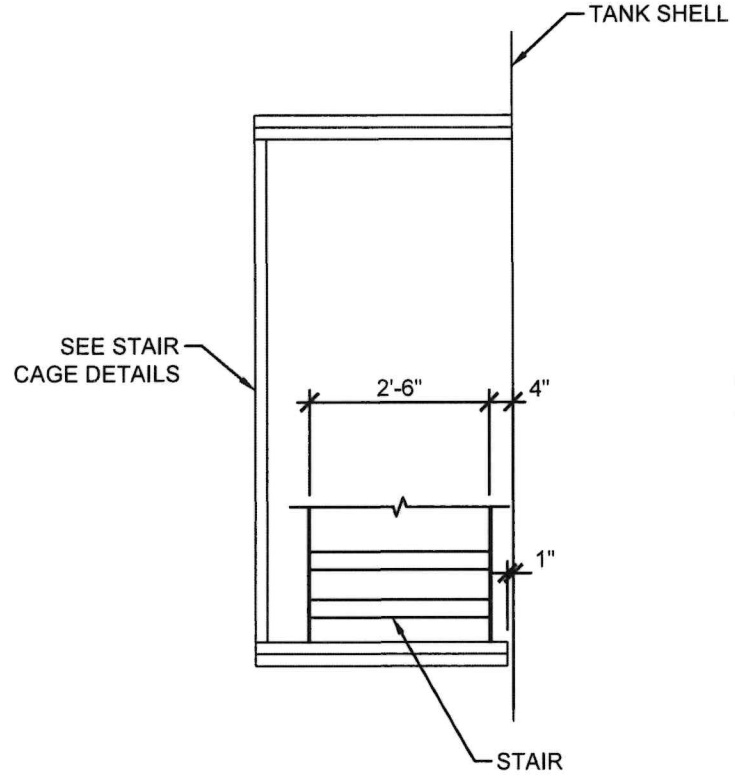

**SECTION A-A**  
SCALE: 3/8" = 1'-0"  
(SUPPORT BRACKET NOT SHOWN)

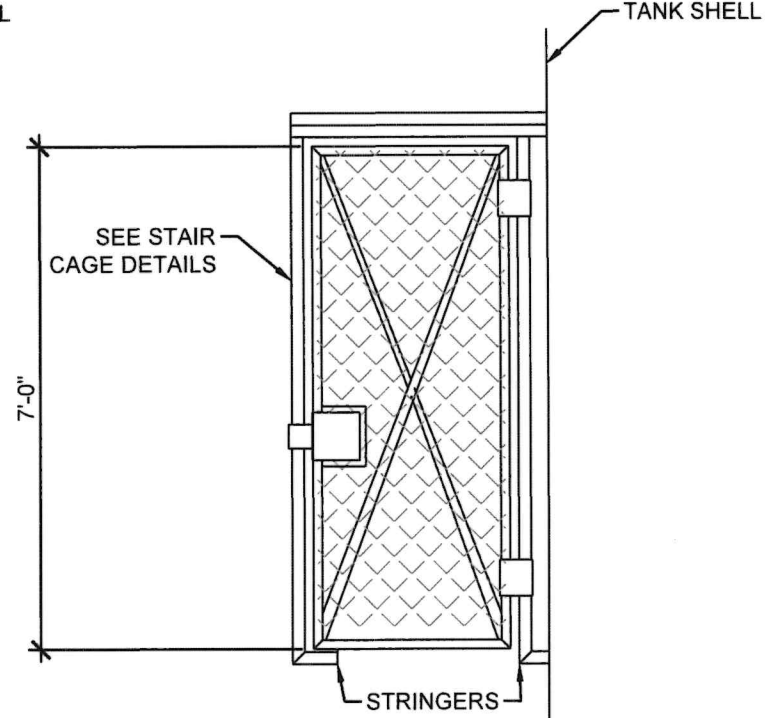

**CAGE DOOR**  
SCALE: 3/8" = 1'-0"



Copyright © 2023 Advantage Technical Services, a California Corporation. All rights reserved

REVISIONS	DATE
	00/00/00



ADVANTAGE TECHNICAL SERVICES, INC.  
805-595-2282  
ATS-SLO.COM

DESIGNED BY: WB	DRAWN BY: DC	CHECKED BY: JB
PREPARED UNDER THE DIRECTION OF: <i>William D. Bellis</i> WILLIAM BELLIS P.E.		
DATE 7/28/2023		DATE

RECOMMENDED: <i>Tony Marraccino</i> TONY MARRACCINO - UTILITY SYSTEMS MANAGER
APPROVED: <i>Will Clemens</i> WILL CLEMENS - GENERAL MANAGER



OCEANO COMMUNITY SERVICES DISTRICT  
WATER STORAGE TANK REHABILITATION

**STAIR CAGE**

SHEET: 9 OF 9
SCALE: VARIES

## **APPENDIX C**

### **DIVE INSPECTION REPORTS – EXISTING WELDED TANK**



**INSPECTION REPORT FOR THE  
OCEANO COMMUNITY SERVICES DISTRICT'S  
297,000 GALLON WATER STORAGE TANK  
JULY 22<sup>ND</sup>, 2020**



**Advantage Technical Services, Inc.  
www.ats-slo.com | License #96111**

**INSPECTION REPORT FOR  
OCEANO COMMUNITY SERVICE DISTRICT'S  
297,000 GALLON WATER TANK**

**JULY 22<sup>ND</sup>, 2020**

**REVISION DATE: N/A**

Pursuant to the American Water Works Association's Manual of Water Supply Practices, Steel Water-Storage Tanks, M42 and California Business and Professions Code section 6735, the engineering report contained herein has been prepared by or under the direction of the following Registered Engineer:

**ADVANTAGE TECHNICAL SERVICES, INC.  
6661 FERN CANYON LANE  
SAN LUIS OBISPO, CA 93401  
805-595-2282**

**UNDER THE SUPERVISION OF:  
WILLIAM D. BELLIS**

*William D. Bellis*

---

Registered Civil Engineer, CA C55334



## **EXECUTIVE SUMMARY**

Advantage Technical Services, Inc. (ATS) inspected the Oceano Community Services District's 297,000-gallon Storage tank on July 22<sup>nd</sup>, 2020. The tank interior was inspected above and below the water line using sanitary diving procedures. The following is a summary of what appear to be the most significant elements:

1. The roof is severely corroded. ATS provided temporary repair to seal 10 existing holes and prevent an unsanitary condition.
2. The roof at the base of the guardrails is severely corroded and the guardrails will not provide worker protection. This is a hazardous condition. Access should only be allowed with an engineered system and hazard mitigation plan.
3. Serious corrosion and metal loss are present on some of the roof support rafters. It is unlikely that the roof structure meets minimum safe design standards.
4. Serious corrosion has damaged the roof vent hood attachment brackets. The vent hood is not fastened as designed and could blow off of the roof in high winds.
5. The steel plate in the tank shell and bottom provide the containment portion of the tank and these are in good condition so rehabilitation is still a reasonable option.

## **SCOPE, OBJECTIVE, AND LIMITATIONS**

An inspection was completed on the interior and exterior of the steel potable water storage reservoir. Principle Inspector/Engineer, Will Bellis, P.E. and ATS associates provided the tank inspection.

ATS personnel completed a preliminary inspection for safe access with particular attention to work from the elevated location and the confined space. It was determined that the existing roof fall protection does not meet OSHA regulatory requirements. Our on-site Engineer determined the acceptability of temporary fall protection anchor points, temporary tie-backs and confirmed the applicability of our standard procedures for mitigating the risks. The temporary protection equipment is part of ATS tooling and is not appropriate for permanent installation so it was removed upon completion of this work.

ATS divers have experience and certifications that meet or exceed the requirements of the American Water Works Association Manual of Water Supply Practices, Steel Water-Storage Tanks, M42, AWWA C652 Standard for Disinfection of Water Storage Facilities and OSHA regulations for technical or commercial diving. Additionally, our team's certifications or licenses include a Registered Professional Engineer, API 653 Tank Inspector, AWS Certified Welding Inspector, National Association of Corrosion Engineers Level III Coating Inspector, and American Society of Nondestructive Testing Level III Engineer. With these applicable credentials and combined experience of over five hundred tank dive inspections our team leads the industry.

The diver's air supply is supplied by air hoses from the surface using either a dive compressor or bottled air. The diver's air supply system offers triple redundancy; including a self-contained system maintained in the diver's possession and control. A full-time

communication system supports documentation of findings and operational or emergency communications.

All disinfection procedures are in accordance with the American Water Works Association Standard for Disinfection of Water-Storage Facilities (ANSI/AWWA C652-11).

The photographs provided within this report display representative views and subsequent analysis. Digital video, also included, provides additional documentation of the conditions.

The observations made during the inspection, and included in this report, provide a reasonable evaluation of the tank conditions at the time of the inspection. Considerations of safe access and reasonable care were observed in making and reporting the observations. Latent defects or conditions found during subsequent cleaning, inspections, or other work at the tank must be brought to the Engineer's or Owner's attention.

## **OBSERVATIONS**

### **General Tank Data**

40 ft. Diameter x approx. 32' ht

Type: Ground supported welded steel reservoir

Media Stored: Potable water

Diameter: ~~Approximately 31.75 ft. (40 ft. from name plate, not measured)~~

Height: ~~40 ft. (from name plate, not measured)~~

Water level during inspection: Approximately 39 ft.

Design liquid level: 32 ft. (shown on name plate, may be lower to match vol. on plate)

### **Foundation**

The concrete ring foundation is in good condition overall. Minor cracks are present but these appear to be normal and adequately tight to prevent associated damage or significant rebar corrosion. No significant settlement was noted. No spalling or visible deterioration of the concrete was noted.

### **Exterior Shell**

The exterior shell coating is in fair condition. Scattered general corrosion is present and some minor metal loss was noted in one area.

Serious corrosion is present on the chime which is the bottom extension at the base of the shell. The corrosion on the chime appears to have started from the inaccessible area on the underside of the bottom and progressed from there. If this corrosion continues to the shell weld, a new bottom may be required.

Coatings appear to be losing the ability to protect the steel from corrosion. Significant chalking was noted. Chalking is the formation of friable, or easily removed powder, on the surface of the coating. The "powder" is evolved from the coating itself. The level of

chalking helps define the amount of degradation and its presence affects the adhesion of top-coats. The ASTM D 4214 Standard Test Method for Evaluating the Degree of Chalking of Exterior Paint Films was used.

Dry film thickness was measured on the shell at mid height and found to average about 8 mils. It appears that the only coating on this tank is from original construction.

## **Exterior Roof**

The exterior roof coating is in poor condition and has not been protecting the steel for an extended time. Serious corrosion is present in approximately 50 localized areas. 10 holes, caused by rusting, were sealed using fiber reinforced NSF approved epoxy resin in order to provide a temporary repair and help prevent rain water intrusion.

Corrosion at the base of the guardrails has severely damaged the structure and the guardrails will not provide the intended safety barrier. This is a hazardous condition.

Dry film thickness was measured on the roof and found to average about 5 mils. It appears that the only coating on this tank is from original construction.

## **Interior Bottom**

The bottom plate is in good condition with no significant pitting or other forms of metal loss. The coatings are in fair condition overall. The cathodic protection is protecting some scattered areas of coating failure. Many scattered areas of blistering are present. Blisters are densely patterned and are less than ½ in. diameter.

Dark brown sediment material was present over approximately 50% of the bottom area.

## **Interior Shell**

Interior shell plate is in fair condition. The epoxy coatings are in good condition overall. Some scattered blisters are present on the shell. The blisters were un-broken and no associated corrosion was present. The blisters were left intact by the diver inspector.

## **Interior Roof Plate**

The interior roof plate is in poor condition with significant metal loss that has penetrated from the exterior. Corrosion from the interior side is isolated to only a few areas with mostly general corrosion. Corrosion and staining are present at the un-seal welded lap joint.

## **Roof Structure**

The roof is supported by a round tubular center column with wide flange rafters. The base plate is welded to the bottom. Minor bowing is visible in the rafters. This may be caused by settlement at the center portion of the tank that is greater than at the shell.

The structural steel is in poor condition. Serious corrosion and metal loss are present on some rafter flanges. It is unlikely that the roof structure meets minimum safe design standards specified by the Building Code.

## **Cathodic Protection System**

The elements of the sacrificial anode cathodic protection system appeared to be intact and operating normally. The reference cell appeared to be in normal operating condition. The edges of the hand-holes have significant corrosion.

## **Appurtenances**

Level Gauge: The main cable was broken but was repaired by ATS. The float is located close to the inlet that enters the tank through the roof. The vibration cause by tank filling creates excessive movement at the level gauge float. This movement is causing excessive wear of the cable, cable attachment points and cable guides.

Exterior Ladder and Cage: These areas are in poor condition overall. Serious corrosion is present in scattered areas including ladder support legs. Metal loss is approximately 50% of the original thickness of the ladder stringer in one location.

Roof Fall Protection: No roof fall protection is present.

Roof Guardrail: The partial guardrail at the roof hatch is in poor/hazardous condition due to serious corrosion.

No guardrail is provided for other areas of the roof edge. The ladder opening is not protected by a swinging gate.

Roof Hatch: One lockable square roof hatch is located at the top of the interior ladder. The hatch is in fair condition. The appropriate curb or neck and downward overlap of the cover are present. Some minor areas of general corrosion are present.

Internal Ladder: The internal ladder is in fair condition.

Overflow: The visible exterior of the overflow steel appears to be in good condition with no significant corrosion. The internal areas of the overflow weir have some localized corrosion. The pipe appears to be free from obstructions.

Outlet: The outlet penetration in the tank shell appeared to be in normal condition.

Inlet: The inlet and riser pipe were in good overall condition with staining and minor corrosion.

Drain: The drain appears to be in fair condition with some minor corrosion.

Roof Vent: The roof vent screen appears to be bug proof. The hood attachment brackets are corroded to the point of losing all integrity. Significant corrosion is present on the hardware and band clamps.

Manways: Two mono-bolt manways are present. The manways were in good condition overall on the interior. Minor corrosion was present but no significant metal loss was noted.

## **ENVIRONMENT AND OPERATING CONDITIONS**

This tank is located in a water facility buildings and equipment.

The tank site conditions are typical for California coastal areas with regular fog, dew and salts which significantly increase corrosion rates on exterior surfaces and interior vapor space.

## **RECOMMENDATIONS**

The following recommendations are based on our experience as engineers and inspectors with regard to the best industry practices used by both public and private tank owners. The intent is to provide information that will likely help lower risks, optimize water quality and increase long term value for the tank owner(s). Our scope of work does not include a safety audit or evaluation but we are making recommendations where we have noted potential issues. The owner's insurance provider or safety consultant should be consulted for a review of the safety features of this facility where desired.

1. The tank appears to have only the 30-year-old original coating. The coatings on portions of this tank have not been preventing corrosion for years. Serious damage has resulted. Recoat the interior and exterior as soon as possible to prevent additional damage and repair cost.
2. Rehabilitate the roof. Consider options including: 1) Welded patch plates to repair areas on roof and replacement of selected rafters and 2) Replacing the entire roof.
6. Do not allow personnel to access the roof without engineered anchorage and fall protection. For this inspection, ATS provided engineering evaluation only for temporary anchorage and temporary tie-back to protect personnel for work on the tank roof.
7. The roof at the base of the guardrails is severely corroded and the guardrails will not provide protection. Install base plates where serious corrosion has reduced guardrail structural attachment to the roof.
3. Movement from the inlet is wearing out the components of the level gauge. Install a stilling well for the level gauge float or use some other design solution to keep the

- adjacent inlet from causing excessive movement or consider a change to a pressure sensing system. Replace worn level gauge components during rehabilitation.
4. Repair vent hood brackets as soon as possible. Serious corrosion has damaged the roof vent hood attachment brackets. The vent hood is not fastened as designed. Loose vent hoods have been known to blow off of roofs in high winds.
  5. Check the shell height, volume and design liquid level shown on the tank name plate. The plate shows the design liquid level of 32'. It appears that the shell is 31.75 ft. Also, the nominal capacity does not calculate correctly for the dimensions shown. If this is determined to be an error on the name plate, it should be corrected.
  6. Control corrosion at the tank chime (bottom extension at the shell) to help prevent the need for a bottom replacement.
  7. Continue to provide regular inspections. AWWA D100-11 Standard for Welded Steel Tanks Specifies inspection and corrective maintenance every three years. AWWA Manual of Water Supply Practices, M42, for Steel Water Storage Tanks (2013) states "the tank should be inspected at least once every 3 to 5 years or as required by state regulatory agencies". M42 additionally states that "The results of the tank evaluation or pre-bid inspection should be certified by a professional engineer."





Overall view of the tank.

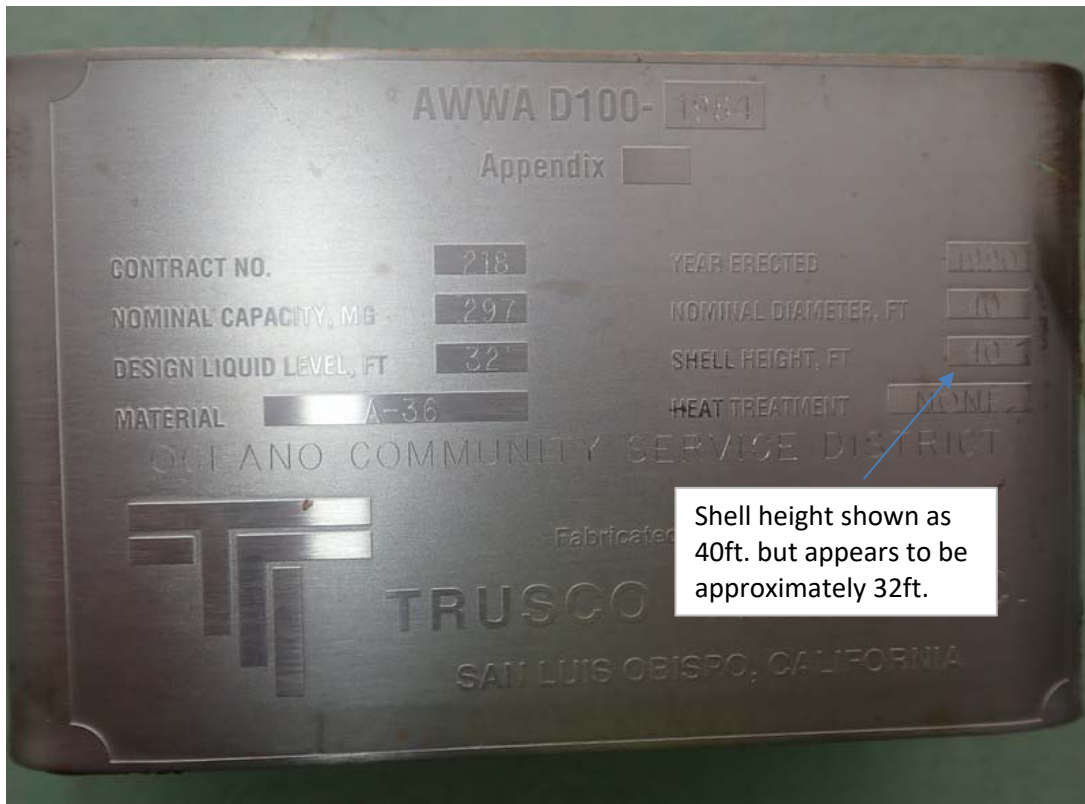

Tank nameplate. The stated shell height of 40 ft. appears to be incorrect. The design liquid level of 32 ft. gives a volume of 0.3 MG so there may be an error there too.



This view shows a typical mechanical anchor along with lower shell. Significant corrosion is present.



This close view of the exterior lower shell and bottom chime shows serious corrosion found on the outer edge of the chime. Continued corrosion here will eventually create a condition where bottom replacement is necessary.



The upper shell and roof joint are shown in this photo. The coatings are in fair condition with significant aging of the coating and scattered corrosion.



This is a typical view of the lower exterior shell. Scattered corrosion points are starting where aging coatings are losing the ability to protect the steel.



The roof vent consists of a fiberglass cover over a steel riser pipe.



This is a view of the underside of the vent hood. The screen appears to be intact and bug proof. Serious corrosion has damaged the roof vent hood attachment that keeps the hood from blowing off during high winds.



The exterior roof is the area with the worst corrosion on the tank. Approximately 50 locations have serious metal loss. ATS repaired the 10 worst locations that had holes where the 3/16inch thick roof has rusted through.



This is an addition view of a typical corroded area on the tank roof.



This is one of 10 holes in the roof where ATS provided temporary repairs to immediately seal the roof and meet regulatory requirements.



This view shows 2 locations after temporary repair of the holes using fiber reinforced epoxy. The epoxy is NSF 61 certified for use and contact with potable water.



This photo shows one of several areas of serious corrosion on the exterior ladder.



This is a close view of the ladder area shown above. Approximately 50% of the ladder stringer metal thickness is lost to corrosion.



This photo shows serious corrosion and a hole at the base of a guardrail post. This guardrail was designed to help provide safe access to the roof but clearly it is severely weakened.

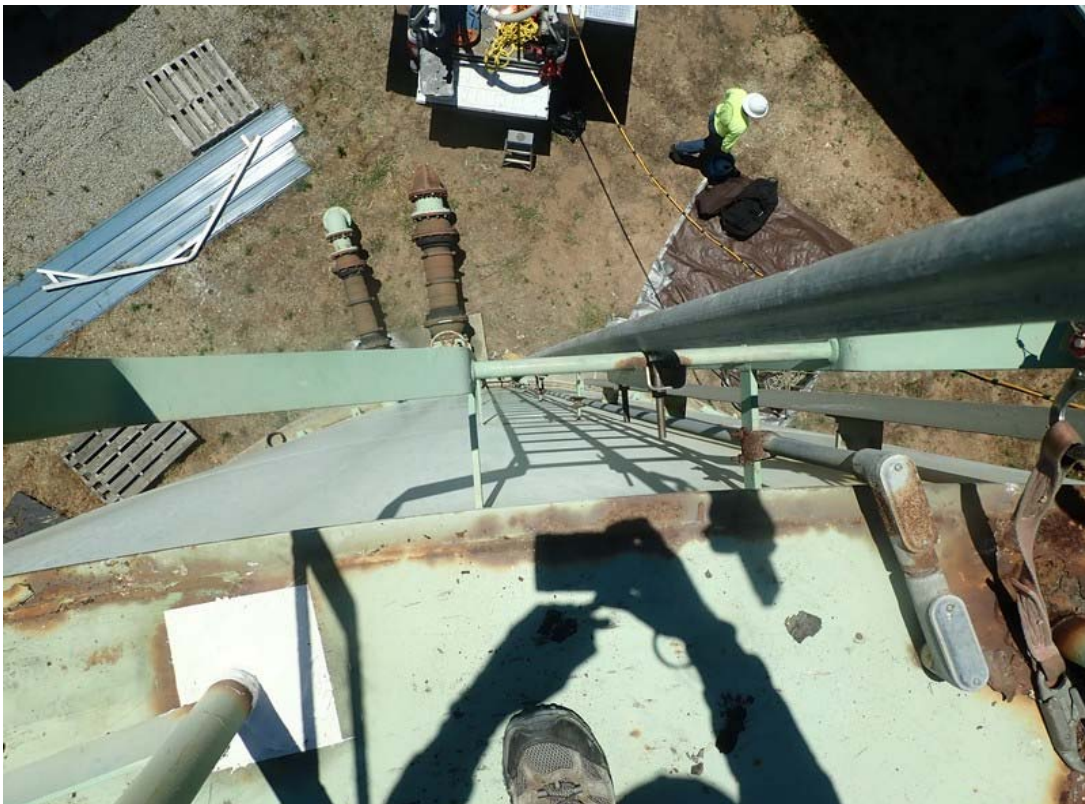

This view shows the guardrail post after repair by ATS. The repair only provides a temporary non-structural seal for public health purposes. The patch does not make the guardrail or roof safe for access by personnel without special techniques.





Exterior view of the manway.



This view shows exterior piping with some corrosion with what appears to be insignificant metal loss. Flexible couplings are in place for seismic movement.



This photo shows a corrosion spot at the interior side of the shell to roof joint. ATS installed a temporary repair to seal this hole. This was the largest hole in the roof but many other locations of serious corrosion are present.



This view is representative of the conditions found on the interior shell, roof plate and rafter.



Upper interior shell. Water staining is visible but only minor corrosion is present.



Interior shell in the submersion zone. This view shows a horizontal weld with sediment or staining visible along the top. The interior shell steel appears to be in good condition.

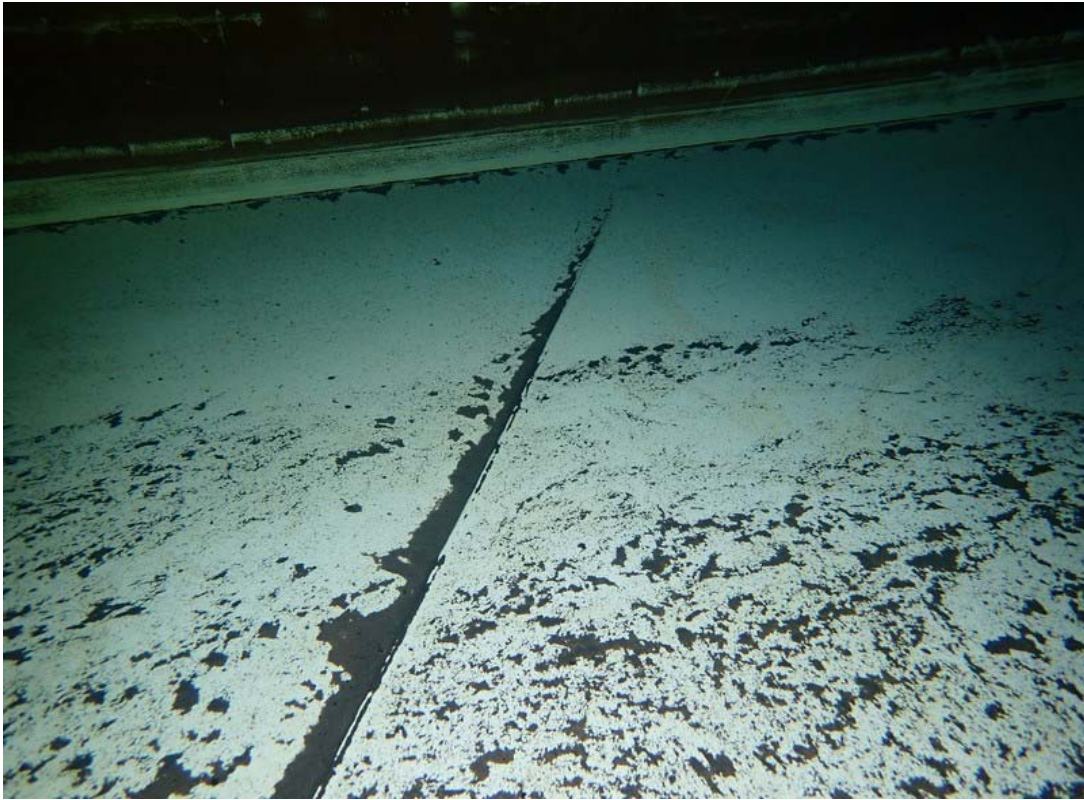
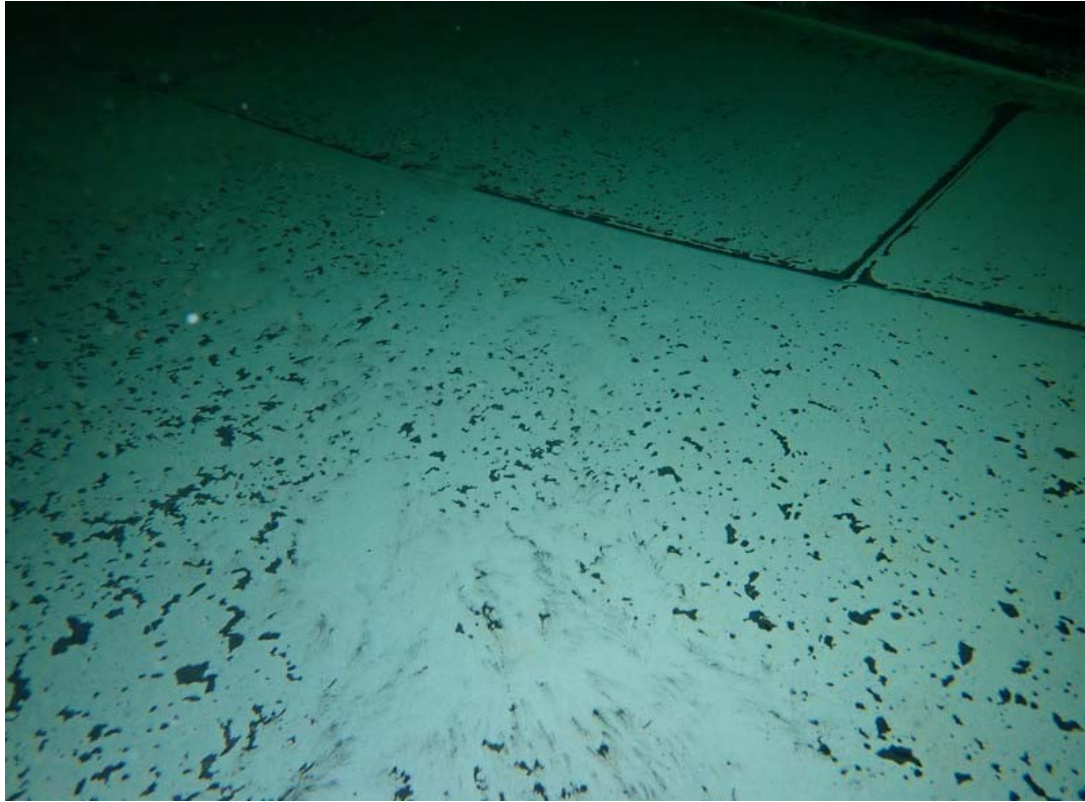

Photo of the interior bottom shell and shell coupling shows the typical condition found. No significant corrosion was noted.



This photo provides a close view of the area shown in the top photo this page. Some scattered blistering is visible (arrow) but no significant corrosion is present.



Sample area of bottom showing typical conditions. Spots of sediment are scattered and sediment removal was not part of the scope of work. No significant corrosion was noted although sediment reduces the ability to see corrosion.



Close view of a weld in the bottom.

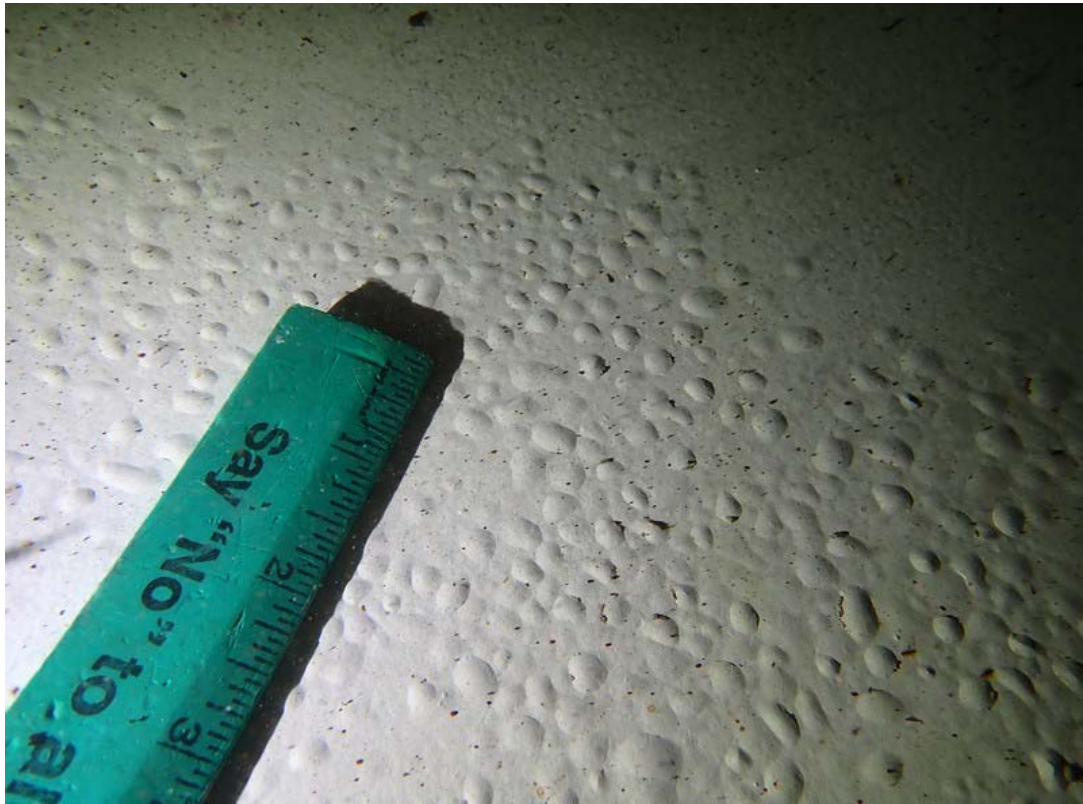

Close view of the interior bottom at an area with a dense pattern of small unbroken blisters. Blisters like this are not uncommon. Unbroken blisters usually do not allow significant corrosion.



This view shows bottom sediment.



This shot was taken looking upward at the center column. All coatings on the column were in fair condition and no significant corrosion was present.

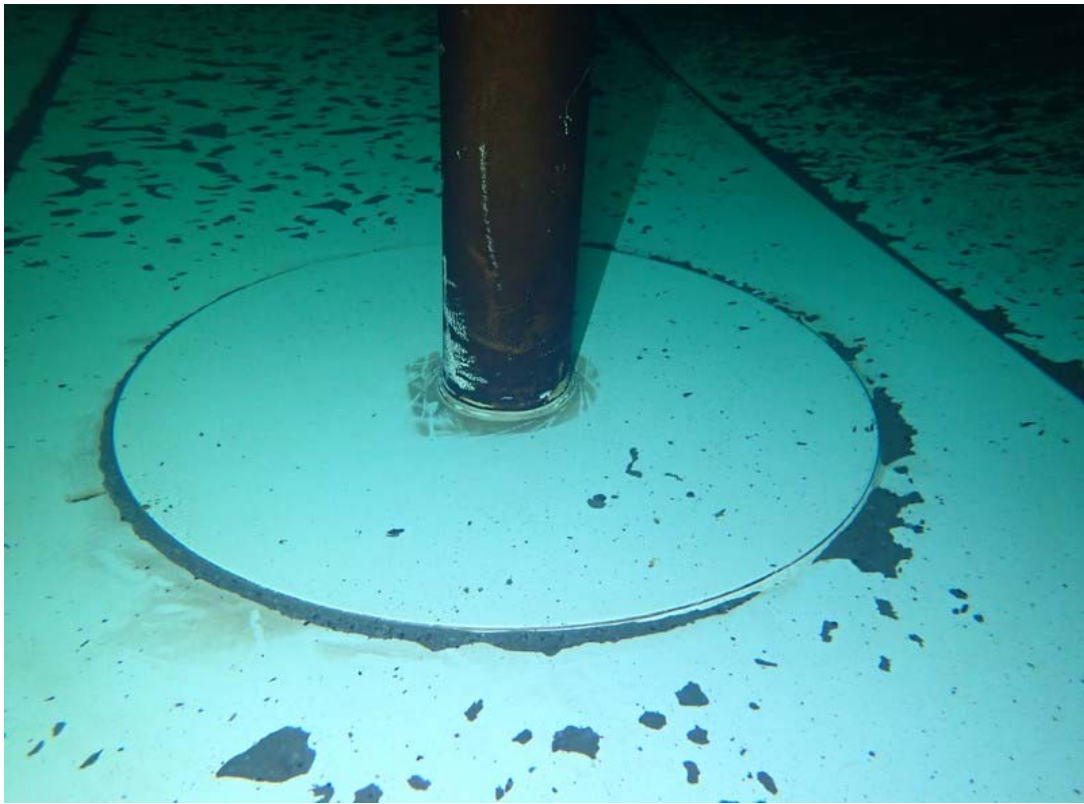

This view is of the lower portion of the center column and base plate. No significant corrosion is present.



Upper center column, rafters and roof plate.



Close view of the center support and rafters. Significant corrosion and heavy staining is visible at the ends of the rafters and at inaccessible areas.





Interior roof plate and rafters. Broad view. Some minor bowing is present in the rafters. This view shows an example of nearly rust free plate but a hole is visible at the shell to roof joint (arrow). The hole was sealed by ATS.



This is a close view of the top flange of a rafter at one of the numerous areas with serious corrosion. This rafter flange has serious metal loss that affect the load carrying capacity.



Roof plate rafter with visible corrosion.



An additional view of the interior roof.



View of the roof hatch from the interior. The arrow indicates the location of a hole that was sealed by ATS.



This view shows the interior ladder below the surface.



Overflow piping and support as viewed looking upward from the bottom.



This view is of the inside of the overflow weir. Some corrosion is visible but the pipe appears to be free of obstructions.



Shell mounted piping as viewed from the interior.



Interior view of the shell nozzle on the right side of the top photo of this page. Blisters in the coating are visible as rounded white spots. Minor corrosion is present.



This view shows the interior side of the sample tap. Blisters in the coating are visible.



This view shows the interior of the drain pipe. Some corrosion is visible on the interior edge of the pipe (arrow).



Level gauge float with temporary repair to the attachment. The interior float is not designed for the amount of movement that is created by the adjacent high inlet.



Level gauge guy wire and retainer ring on the float. The arrow shows the wear on the ring from excessive movement of the float from the adjacent inlet.



# DAILY REPORT

**PROJECT:** 0.4MG Tank Inspection

**LOCATION:** Tank Site

**CLIENT:** Oceano CSD

**DATE:** 7/22/20

**Gage:** Elektro-Physik Type 1 Pull off gage S/N 025962

	<u>Roof</u>	<u>Roof</u>	<u>Shell Mid Ht. @ Ladder</u>
	5.3 mils	4.7 mils	7.4 mils
	5.6 mils	5.2 mils	7.1 mils
	5.7 mils	5 mils	8.1 mils
	3.4 mils	4.6 mils	10.4 mils
	4.3 mils	5.4 mils	9.3 mils
Average	4.86 mils	4.98 mils	8.46 mils

	<u>Shell Mid Ht. @ Ladder</u>
	5.9 mils
	8.4 mils
	8.7 mils
	8 mils
	7 mils
Average	7.6 mils

**END OF APPENDIX C-DIVE REPORT**



# **APPENDIX D**

## **PROJECT LOCATION & EXISTING CONDITIONS**

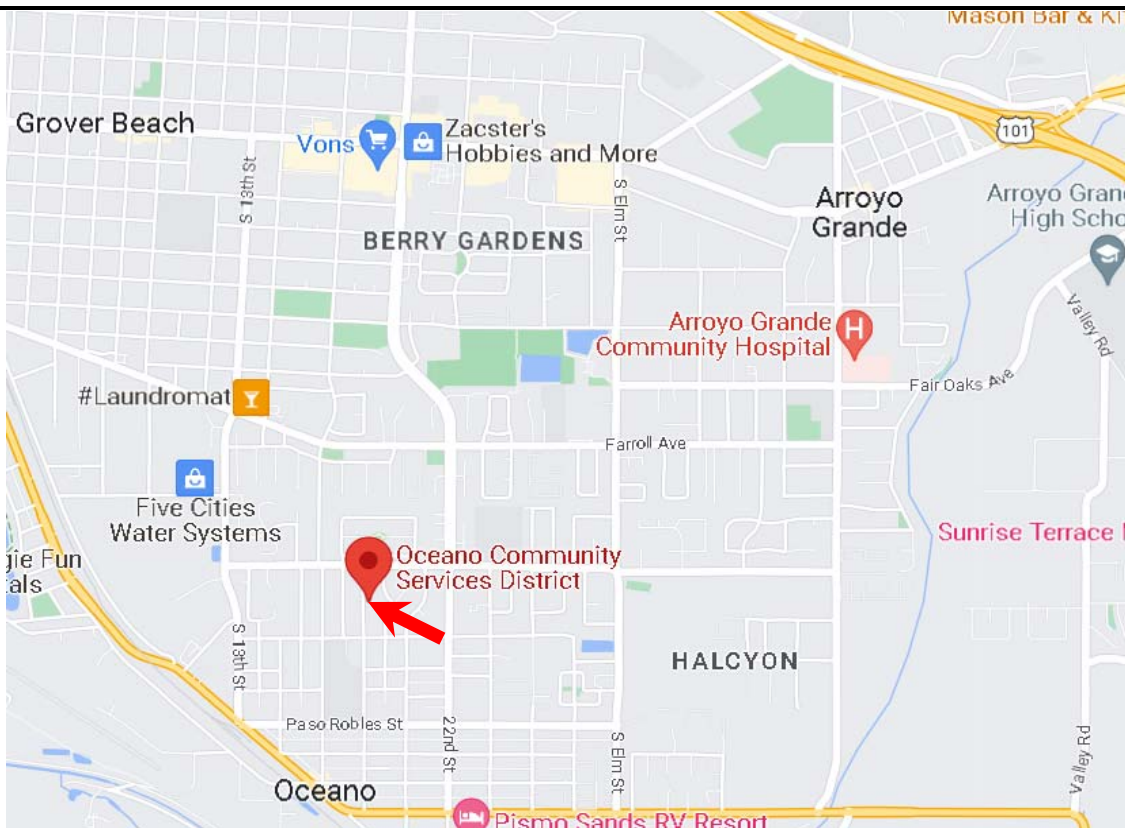

Project site location: Across from 1348 19th. St., Oceanó, CA. Tank site indicated by the red arrow. GPS Coordinates: 35°06'19.5"N 120°36'37.2"W



Plan view of site.

**TITLE: PROJECT SITE LOCATION**

**PROJECT:** Oceanó Community Services District, Water Tank Recoating and Roof Replacement Project

**DATE:** 7/16/2023 (Rev. 7/26/2023)

ATS, Inc - Project Manual Appendix A-1



View of tank and portion of Contractor "lay-down" area.



Access gate and tank site.

**TITLE: PROJECT SITE PHOTOS**

**PROJECT:** Oceano Community Services District, Water Tank Recoating and Roof Replacement Project

**DATE:** 5/11/2022 (Rev. 7/26/2023)  
(vi) Technical Specifications

ATS, Inc - Project Manual A-2



Ponding and corrosion indicate that the compression ring has an upward tilt that will require adjustment to facilitate the fit-up and welding of the new 1:12 roof.

Contractor to provide new roof penetration with coupling with plug near the roof hatch.



Existing guardrails are severely corroded and do not provide adequate strength to function as guardrail. Persons accessing the tank roof shall provide fall protection not associated with existing guardrail.

**TITLE: PROJECT SITE PHOTOS**

**PROJECT:** Oceano Community Services District, Water Tank Recoating and Roof Replacement Project

**DATE:** 5/11/2022 (Rev. 7/26/2023)

ATS, Inc - Project Manual Appendix A-3

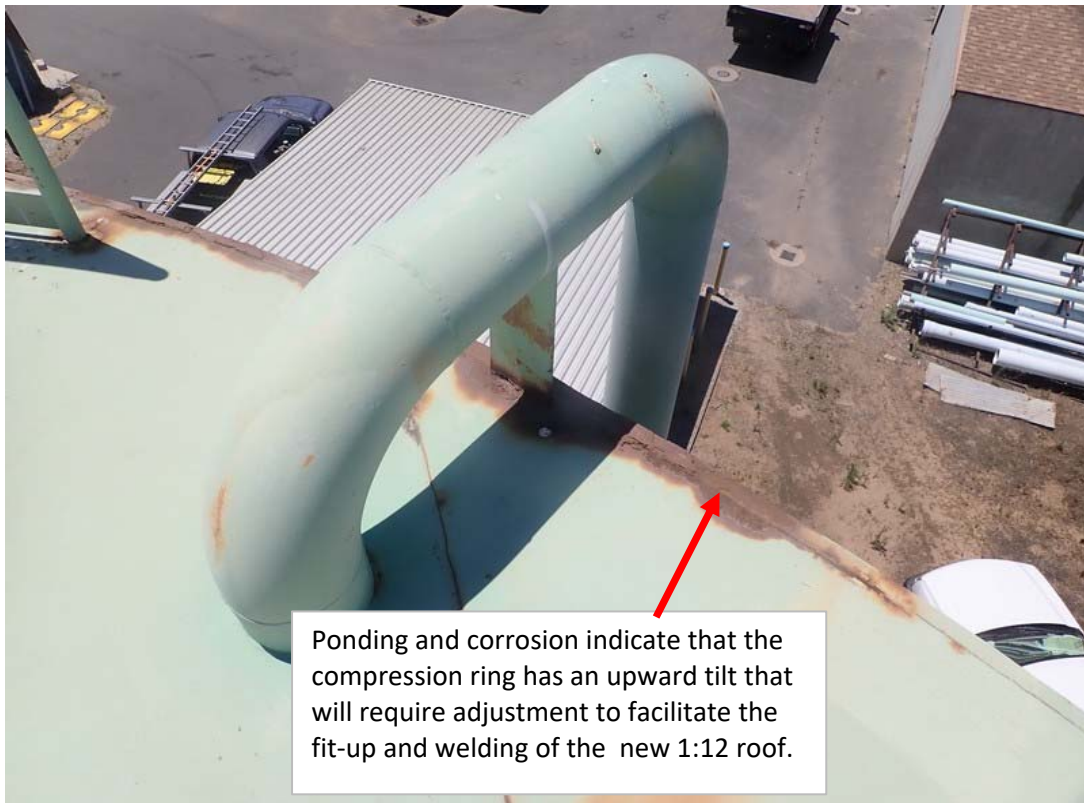

Existing inlet piping on the tank roof. This pipe will be reattached to the new roof.



This view shows the existing inlet piping.

**TITLE: PHOTOS OF EXISTING TANK DETAILS - INLET PIPING**

**PROJECT:** Oceano Community Services District, Water Tank Recoating and Roof Replacement Project

**DATE:** 5/11/2022  
(vi) Technical Specifications

ATS, Inc - Project Manual  
Appendix A-4



Existing inlet and only a few inches of freeboard.



Original name plate with incorrect height shown.

**TITLE: PHOTOS OF EXISTING TANK DETAILS**

**PROJECT:** Oceano Community Services District, Water Tank Recoating and Roof Replacement Project

**DATE:** 5/11/2022  
(vi) Technical Specifications

ATS, Inc - Project Manual Appendix A-5



Existing roof column, roof structure and plate that are to be replaced with new formed plate roof.

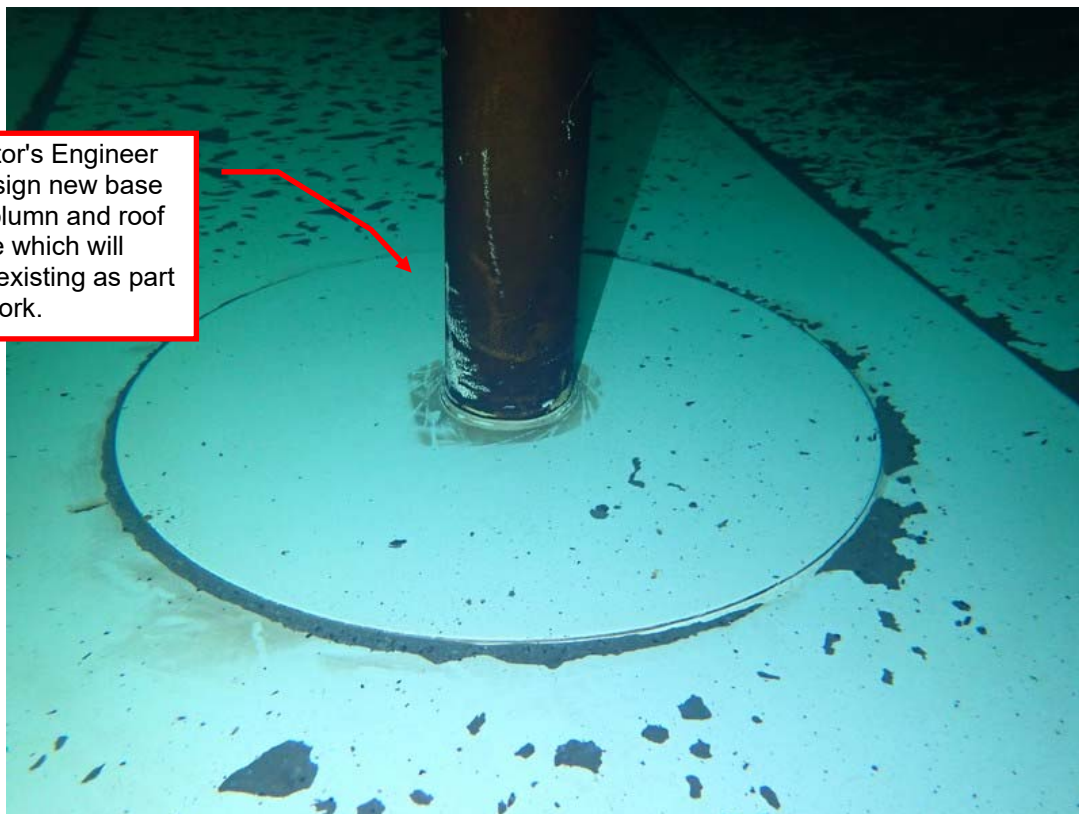

Contractor's Engineer shall design new base plate, column and roof structure which will replace existing as part of this work.

Existing column and base plate.

**TITLE: PHOTOS OF EXISTING STRUCTURE TO BE REPLACED**

**PROJECT:** Oceano Community Services District, Water Tank Recoating and Roof Replacement Project

**DATE:** 5/11/2022  
(vi) Technical Specifications

Appendix A-6  
ATS, Inc - Project Manual



Existing cathodic protection system shall be removed as part of the work.



This photo shows the existing level gauge float and guy wire. Wear is visible from wave action produced by inlet flow. A stilling well will be provided as part of this work.

**TITLE: TANK DETAILS - EXISTING CATHODIC PROTECTION AND FLOAT**

**PROJECT:** Oceano Community Services District, Water Tank Recoating and Roof Replacement Project

**DATE:** 5/11/2022  
(vi) Technical Specifications

Appendix A-7  
ATS, Inc - Project Manual





Existing cathodic protection panel. The panel and post are to be removed. The wires shall be removed to the first junction box. The conduit shall be capped and abandoned in place.



The circuit breaker for the cathodic protection system is in this panel. Other items are on the same breaker.

**TITLE: PHOTOS OF EXISTING CATHODIC PROTECTION SYSTEM**

**PROJECT:** Oceano Community Services District, Water Tank Recoating and Roof Replacement Project

**DATE:** 7/26/2023  
(vi) Technical Specifications

Appendix A-8  
ATS, Inc - Project Manual



Apparent first junction box from the CP panel located in the well shed near the breaker box.



View of site looking northward along the eastern fence

**TITLE: PHOTOS OF CATHODIC PROTECTION CONDUIT AND SITE AT BACK FENCE**

**PROJECT:** Oceano Community Services District, Water Tank Recoating and Roof Replacement Project

**DATE:** 7/26/2023  
(vi) Technical Specifications

ATS, Inc - Project Manual Appendix A-9

**OCEANO COMMUNITY SERVICES DISTRICT**

**Water Storage Tank Rehabilitation**

**REPORTS, SUPPLEMENTS, ATTACHMENTS, MODIFICATIONS AND EXHIBITS**

**FOR**

**OCEANO, CA**

**CONTRACT NO. 2023-03**

- A. Federal Award Identification #B-22-UC-06-0508 (2022 Community Development Block Grant Funds)**
- B. Federal Labor Standards Provisions – U.S. Department of Housing and Urban Development Office of Davis-Bacon and Labor Standards**
- C. Contract Work Hours and Safety Standards Act**
- D. Copeland “Anti-Kickback” Act**
- E. Code of Federal Regulations – Title 24 Housing and Urban Development**
- F. Requirements For Affirmative Action to Ensure Employment Opportunity (Executive Order 11246)**
- G. Civil Rights, Employment and Contracting Opportunities and Other Federal requirements**
- H. The Davis-Bacon Act**
- I. Davis-Bacon Requirement – Posting The Wage Decision and Notice to Employees**
- J. The Davis-Bacon Act – Jobsite Poster (English and Spanish)**
- K. Davis- Bacon Labor Standards**
- L. The General Decision Number: CA20230012 10/06/2023**

**SUBRECIPIENT AGREEMENT FOR 2022 COMMUNITY DEVELOPMENT BLOCK GRANT FUNDS  
BETWEEN  
THE COUNTY OF SAN LUIS OBISPO AND THE OCEANO COMMUNITY SERVICES DISTRICT**

**THIS SUBRECIPIENT AGREEMENT FOR 2022 COMMUNITY DEVELOPMENT BLOCK GRANT (CDBG) FUNDS BETWEEN THE COUNTY OF SAN LUIS OBISPO AND THE OCEANO COMMUNITY SERVICES DISTRICT ("Agreement")** is made and entered into on the date and year last written below by and between the County of San Luis Obispo, a political subdivision of the State of California, hereinafter called "Recipient," and the Oceano Community Services District, a government entity in the State of California, located in the County of San Luis Obispo, hereinafter called "Subrecipient"; jointly referred to as "Parties."

**WITNESSETH**

**WHEREAS**, the Subrecipient applied for 2022 CDBG funds to support the Water Reservoir Rehabilitation Project (hereinafter called "Project"); and

**WHEREAS**, the Recipient and the Subrecipient entered into an Agreement to implement the Housing and Community Development (HCD) Act of 1974, herein called the "Act". Said Act is omnibus legislation relating to federal involvement in a wide range of housing and community development activities and is administered by the federal Department of Housing and Urban Development (hereinafter "HUD"); and

**WHEREAS**, on April 19, 2022, the County of San Luis Obispo Board of Supervisors approved the County of San Luis Obispo (County) Program Year 2022 Action Plan of the Consolidated Plan and projected use of funds pursuant to applicable federal regulations (24 CFR Part 570) (hereinafter referred to as the "2022 Action Plan"); and

**WHEREAS**, this agreement shall remain in effect throughout the implementation of projects specified in the Urban County of San Luis Obispo's Program Year 2022 Action Plan of the 2020 Consolidated Plan (Federal Award Identification #B-22-UC-06-0508) and any amendments thereto; and

**WHEREAS**, the Federal Award date identified in the Grant Agreement for the 2022 CDBG funds is September 20, 2022; and

**WHEREAS**, the Recipient completed the necessary federal environmental review documents per 24 CFR Part 58 to account for all CDBG funds allocated to the Project; and

**WHEREAS**, the Parties desire to enter into this Agreement to govern the use of the CDBG funds for the Project; and

**NOW, THEREFORE**, it is agreed between the parties hereto that:

This Agreement sets forth the responsibilities of the Recipient and the Subrecipient accomplishing the objectives of the Community Development Block Grant (CDBG) program (CFDA Title #14.218) as set forth in the HCD Act.

1. **Scope of Work.** County hereby engages Subrecipient to perform, and Subrecipient hereby agrees to perform for the County, the services set forth in Exhibit A, attached hereto and incorporated herein by reference, all pursuant to the terms and conditions hereinafter set forth.
2. **Compensation.** Subrecipient shall be compensated by County for performing said work in accordance with Exhibit B, attached hereto and incorporated herein by reference.
3. **Effective Date and Duration.** The effective date and duration of this Agreement shall be as set forth in Exhibit C, attached hereto and incorporated herein by reference.
4. **General Conditions.** Subrecipient and County shall comply with all provisions of County's General Conditions as set forth in Exhibit D, attached hereto and incorporated herein by reference.
5. **Special Conditions.** Subrecipient and County shall comply with all provisions of County's Special Conditions as set forth in Exhibit E, attached hereto and incorporated herein by reference. In the event of conflicts between the provisions of the General Conditions and the Special Conditions, the provisions of the Special Conditions shall be controlling.

6. **Lobbying Form and Disclosure.** Subrecipient shall document its compliance with certifications and disclosure as required under the lobbying and disclosure requirements, as set forth in Exhibit G, attached hereto and incorporated herein by reference.
7. **Agreement Signatures.** This Agreement may be executed in counterparts, each of which shall be deemed to be an original, but all of which, when taken together, shall constitute one and the same agreement. This Contract may be executed and delivered by facsimile or scanned signature by any of the Parties and the receiving Party may rely on the receipt of such document so executed and delivered by facsimile or email as if the original had been received.

**IN WITNESS WHEREOF**, the Parties have executed this Agreement on the day and the year set forth below.

**OCEANO COMMUNITY SERVICES DISTRICT**., a government entity

DocuSigned by:  
*Will Clemens*  
BY: 69CA34503919467...  
WILL CLEMENS, General Manager

3/17/2023  
DATED: \_\_\_\_\_

ATTEST:

DocuSigned by:  
*Carey Casciola*  
BY: 71452CA985E8471...  
CAREY CASCIOLA, Secretary

3/17/2023  
DATED: \_\_\_\_\_

**COUNTY OF SAN LUIS OBISPO**, A Public Entity in the State of California

DocuSigned by:  
*Devin Drake*  
BY: DCA937EAE92A4DC...  
Devin Drake  
Director, Department of Social Services

3/21/2023  
DATED: \_\_\_\_\_

APPROVED AS TO FORM AND EFFECT:  
RITA L. NEAL  
County Counsel

DocuSigned by:  
*Benjamin Dore*  
BY: 4CA4DC1E40F7470...  
Deputy County Counsel

3/17/2023  
DATED: \_\_\_\_\_

## EXHIBIT A

### SCOPE OF WORK

**Community Development Block Grant Program.** Pursuant to 24 CFR 200, 24 CFR 570.500(c) and 24 CFR 570.501(b), the Recipient may provide CDBG funds to public or private nonprofit agencies, authorities or organizations, or for-profit entities authorized under 570.201(o) (referred to collectively and individually as “subrecipients”) to be used by the subrecipients to provide certain eligible services in connection with the Recipient’s desire to develop viable urban communities, through community development activities, as specified in 24 CFR 570.200 (“CDBG Program”); and

#### **Water Reservoir Rehabilitation Project:**

##### i. Activity Description

The project will rehabilitate and repair the existing 297,000-gallon water reservoir located at the District owned water yard at 1935 Wilmar Avenue, Oceano, CA 93445. There will be no ground disturbance. The following tasks are associated with the rehabilitation: Drain existing reservoir; Sand blasting of existing steel surfaces; Steel welding repairs; Recoating (exterior & interior); Rehabilitate the roof; Install stilling well for level gauge float; Repair vent hood brackets; replacement of rafters on roof; installation of base plates to guardrails; replace worn level gauge components; modify existing manways; reconfiguring the inlet/outlet piping to improve water circulation; replacing deteriorated valves; replacing ladders; improving vent systems; updating roof hatches to current standards; installing safety devices, railings, and replacing ring seals.

**INTERIOR SURFACE PREPARATION AND COATINGS:** Surface preparation and coatings shall consist of complete removal of all existing interior linings and the replacement with an NSF ANSI Standard 61 certified immersion grade epoxy liner. Apply caulking to wall/roof joint and internal surfaces and crevices that precludes proper coating application. Work shall include proper work area protection scaffolding, disposal of debris, temporary removal of interior features and appurtenances, blasting and cleaning of deteriorated surfaces, recoating work, final cleanup, and reinstallation of interior features and appurtenances.

**EXTERIOR SURFACE PREPARATION AND COATINGS:** Surface preparation and coatings shall consist of the spot repair and full overcoating of the exterior paint system. Spot repair of all paint defect areas, sanding of existing surfaces, and the full overcoating of all surfaces using epoxy and urethane protective coatings. Caulking of the upper exterior chime joint and the crevice between the tank and concrete ring wall. Work shall include work area protection, scaffolding, spot repair and surface preparation of existing exterior coatings, disposal of debris, temporary removal of interfering exterior tank features and appurtenances, blasting & cleaning of deteriorated surfaces, coating, final cleanup, and reinstallation of all features and appurtenances.

**REQUIRED CONSTRUCTION MITIGATION MEASURES:** Construction must occur Monday through Friday between the hours of 7:00 AM and 5:00 PM. No construction shall occur on Saturday or Sunday. On-site equipment maintenance and servicing shall be confined to the same hours.

All construction equipment utilizing internal combustion engines shall be required to have mufflers that are in good condition and tuned according to the manufacturer’s recommendations. Stationary noise sources shall utilize noise reducing engine housing enclosures or noise screens.

Oceano Community Services District must include these mitigation measures in 1) your contract to the lowest and responsible bidder for the repair of the reservoir; 2) included in the Oceano Community Services District's project design and plans.

- ii. Project Type. Water Reservoir Rehabilitation project benefits the low to moderate area in Oceano, CA 570.208(a)
- iii. National Objective. Per 24 CFR 570.208, this project meets the following National Objective: Primarily benefit low – and – moderate income area benefit. The Oceano Community Services District provides public services to an area defined by census tracts as low-to-moderate income. The District contracted with the State Water Resources Control Board to complete a Median Household Income Survey in 2022 to establish a median household income level for state and federal funding program sources. The survey determined that the median household income level in the area served by the Oceano Community Services District was \$52,020.
- iv. Client Documentation. The District shall provide records describing the boundaries of the service area. The District shall provide records describing the median income of the service area or census tracts demonstrating low – to -moderate income levels.
- v. Schedule. The following milestones will occur on the identified date(s).
  1. Request for Bids and Selection of Project Engineer – January – February 2023
  2. CEQA – File Categorical Exemption per CEQA Guidelines – February 2023
  3. Environmental – February-March 2023
  4. Design – March – May 2023
  5. Prepare Contract bid documents – June – July 2023
  6. Contract Bidding and Award – August – September 2023
  7. Pre-Construction Coordination – October 2023
  8. Project Construction – November-December 2023
- vi. Accomplishments. The project will accomplish the following:
  1. Goal Outcome Indicator: Rehabilitation of Water Storage Tank #1 that provides system-wide benefits to the communities of Oceano and Halcyon.
  2. Quantity: 2881 households of which 720 households are low-income and 1296 households are very low-income.
    1. Unit of Measure: Project Completion.
- vii. Reporting. The Subrecipient is responsible for submitting the final Progress Report with the final Payment Request to allow the Recipient to meet federal reporting requirements. The Subrecipient's failure to comply with this requirement could result in forfeit of funds.



**EXHIBIT B**  
**COMPENSATION**

**1. Compensation**

- a. Prior to commencement of services, Subrecipient shall provide, if needed, a valid, current taxpayer ID number to:

County of San Luis Obispo Auditor/Controller  
1055 Monterey Street, Room D220  
San Luis Obispo, CA 93408

County shall pay to Subrecipient, as compensation in full for all services performed by Subrecipient pursuant to this contract, the following sums in the following manner:

- i. County’s Maximum Cost of the Agreement for Services.
  - a. Subrecipient understands that the County shall not expend more than two hundred twenty-five thousand dollars (\$225,000) for all services under this agreement.
  - b. Subrecipient has submitted a program budget that has been accepted as follows:

**Oceano Community Services District**

Water Reservoir Rehabilitation Project CDBG Funds	\$ 225,000.00
<b>TOTAL BUDGET</b>	<b>\$ 225,000.00</b>

- c. Subrecipient shall submit a line-item budget for each type of activity. Said budget shall be subject to approval by the County.
- d. Line-item budget adjustments may be requested by Subrecipient and shall be subject to approval by the County. If the line-item budget adjustment does not increase the contract maximum, an agreement amendment will not be required, only written approval by the County will be required. If the line-item budget adjustment causes the agreement maximum to be exceeded, then an agreement amendment will be required.
- ii. If applicable, should both Parties exercise the right to extend this Agreement as described in Exhibit C, the maximum fund amount for this Agreement in total per extended term is identical to the maximum fund amount in FY 2022–23 pursuant to section 5 of Exhibit C, Option to Extend.

**2. Billing**

- a. Subrecipient shall bill County for services provided under this agreement as follows:
  - i. Subrecipient shall submit to County payment requests by the 15th day of the month following the period for which Subrecipient is billing.
  - ii. Subrecipient shall include only actual expenses for the period for which Subrecipient is billing and Subrecipient’s submitted expense report shall include budget line item(s) and type of activity or activities provided.

**3. Documentation.** The Subrecipient must keep documentation showing that CDBG funds were spent on allowable costs in accordance with the requirements for eligible activities under 24 CFR 570.200 through 570.210, financial management in 2 CFR 200.302, and the cost principles in 2 CFR 200, Subpart E.

- a. Timecard tracking for each employee shall be true to hours worked on the Project and not a percentage allocation. Subrecipients are required to specify time spent working on the project within the documentation.
- b. Documentation indicating income eligibility and method of review are required to be kept in each project file and should be made available to HUD, or the Recipient, upon request.

**4. Payments**

- a. County shall, within thirty (30) days following receipt of a complete payment request meeting all criteria in this Agreement, pay the undisputed charges on the request. If there are any disputed charges on the payment request, County shall include an explanation of the nature of the dispute with the payment for the undisputed charges and shall provide Subrecipient with a Notice of Adverse Beneficiary Determination, if applicable. The Parties shall exchange any information needed to resolve the dispute within a reasonable time.
- b. Absent fraud or mistake on the part of the County or HUD, the determination by the County and HUD of allowance of any expenditure shall be final.

**5. Withholding Payment**

- a. In addition to withholding payment due to disputed charges on a payment request, County shall have the right to withhold payment to Subrecipient under any of the following conditions:
  - i. Subrecipient has not documented or has not sufficiently documented Subrecipient's services according to client records standards of the industry and any special requirements needed by third party payors or federal or state funding agencies.
  - ii. Subrecipient has failed or refused to furnish information or cooperate with any inspection, review, or audit of Subrecipient's program or County's use of Subrecipient's program. This includes interviews and/or reviews of records in any form of information storage.
  - iii. Subrecipient has failed to sufficiently itemize or document an itemized payment request.
  - iv. When in the opinion of County and expressed by County to Subrecipient in writing, Subrecipient's performance, in whole or in part, has not been sufficiently documented.

**6. Reimbursement of Improper Expenditures.** If at any time within applicable statutory periods of limitation it is determined by County or by HUD or its duly authorized representatives, or by the United States Secretary of Treasury or his duly authorized representatives that funds provided for under the terms of this Agreement have been used by or on behalf of Subrecipient in a manner or for purposes not authorized or prohibited by 24 CFR Part 570), or by regulations adopted pursuant thereto, Subrecipient shall, at County's request, pay to County an amount equal to one hundred percent (100%) of the amount improperly expended.

**7. Uniform Administrative Requirements, if applicable**

- a. Subrecipient understands that this Agreement may be funded in part by Federal Grants and, as such, Subrecipient must perform in accordance with the Uniform Administrative Requirements for Federal Awards, codified in 2 CFR section 200.331.
  - i. Subrecipient shall participate in regularly scheduled agreement monitoring designed to review various aspects of services including program and financial compliance issues in accordance with 2 CFR section 200.331. At a minimum, one (1) desk audit monitoring shall be completed by the County each program year in any one of the four (4) quarters. Monitoring shall include, at a minimum, a review of the following financial statements: Balance Sheet, Income Statement and Statement of Cash Flow. Subrecipient shall email financial statements for the desk audit within the timeframe identified in the County's Notice of Monitoring.
  - ii. Subrecipient shall ensure that their annual financial statements are audited by an independent audit firm and a copy is provided to County on an annual basis, no later than thirty (30) days after the completion of the audit.

**8. Ineligible Costs.** The City of Grover Beach is not a participating jurisdiction of the Urban County of San Luis Obispo. CDBG regulations do not allow the expenditure of CDBG funds for the benefit residents of, nor expend these funds within, the City of Grover Beach.

## EXHIBIT C

### DURATION AND EFFECTIVE DATE

1. **Effective Date.** This Agreement shall be effective as of the date this Agreement is signed by County, and that signatory shall be the last to sign.
2. **Service Date.**
  - a. Services shall commence on or after January 5, 2023, and shall end upon the end of the duration date, as outlined in section 3 of this Exhibit, below.
  - b. County specifically acknowledges that in anticipation of execution of this Agreement, services within the scope of this Agreement may have been provided in reliance on assurances that this Agreement would be executed by the Parties by January 5, 2023. Pre-award costs, services may have been rendered from January 5, 2023, to the date the Parties are executing this Agreement, and which were intended in the best interest of the public health and welfare, must meet the requirements provided in the County's grant agreement or other applicable HUD written approval of pre-award costs. County expressly authorizes the retroactive effective date under this Agreement to be January 5, 2023. County also expressly authorizes payment for those services accepted by County at the same rates and under the same terms and conditions as stated in this Agreement, even though this Agreement is being signed after January 5, 2023.
  - c. 24 CFR Part 58 prohibits the commitment or expenditure of HUD funds until the environmental review process has been completed and the subrecipient receives an "Ability to Obligate and Incur Costs" notice from the County.
  - d. If any services from January 5, 2023, until the date of execution of this Agreement have been paid by a purchase order via County Purchasing Agent, that amount shall be deducted from the maximum allowed expenditure under Exhibit B of this Agreement.
3. **Duration Date.** This Agreement shall remain in effect from the effective date, stated in section 1 of this Exhibit, above, until January 5, 2024, unless terminated sooner pursuant to sections 6 or 7 of Exhibit D, or extended pursuant to section 5 of this Exhibit.
4. **Final Payment Request Deadline. Final June invoices shall be received no later than** the fifth (5<sup>th</sup>) business day of July in order to meet County fiscal year-end deadlines. Failure to submit final requests with complete documentation by the aforementioned date may result in forfeit of funds.
5. **Option to Extend.** The Director of the County Department of Social Services or his or her designee may, at his or her sole discretion, grant the Subrecipient up to two (2) one hundred eighty (180) day term extensions upon receipt of a written request from the Subrecipient, provided that the final end date of the term does not extend beyond twenty-four (24) months after the effective date identified in this paragraph. Such extension must be requested no later than forty-five (45) days before the end date of the original term in the case of the first extension, and no later than forty-five (45) days before the end date of the first extension in the case of the second extension.

## EXHIBIT D

### GENERAL CONDITIONS

1. **General Compliance.** The Subrecipient agrees to comply with the requirements of Title 24 of the Code of Federal Regulations, Part 570 (the U.S. Housing and Urban Development regulations concerning Community Development Block Grants (CDBG)) including subpart K of these regulations, except that (1) the Subrecipient does not assume the recipient's environmental responsibilities described in 24 CFR 570.604 and (2) the Subrecipient does not assume the recipient's responsibility for initiating the review process under the provisions of 24 CFR Part 52. The Subrecipient also agrees to comply with all other applicable Federal, state, and local laws, regulations, and policies governing the funds provided under this Agreement. The Subrecipient further agrees to utilize funds available under this Agreement to supplement rather than supplant funds otherwise available.
2. **Notices.** All notices given or made pursuant hereto shall be in writing and shall be deemed to have been duly given if delivered personally, mailed by registered or certified mail (postage paid, return receipt requested) or sent by a nationally recognized overnight courier (providing proof of delivery) to the Parties at the following addresses or sent by electronic transmission to the following facsimile numbers:
  - a. The Recipient's representative who shall be responsible for negotiations, contractual matters, and coordination with the Subrecipient is as follows:
    - i. Name and Title: Marge Castle, Program Manager  
Address: County of San Luis Obispo  
Department of Social Services  
P.O. Box 8119  
San Luis Obispo, CA 93403-8119  
Fax: (805) 788-2457  
Telephone: (805) 788-9491  
Email: mrcastle@co.slo.ca.us
  - b. The Subrecipient's representative who shall be responsible for job performance, negotiations, contractual matters, and coordination with the County is as follows:
    - i. Name and Title: Will Clemens, General Manager  
Address: PO Box 599  
Oceano, CA 93475-0599  
Telephone: (805) 481-6730  
Email: [will@oceanocsd.org](mailto:will@oceanocsd.org)  
Entity UEI: #VHNJTY1J5V6
  - c. Any such notice shall be deemed to have been received:
    - i. In the case of personal delivery or facsimile transmission with confirmation retained, on the date of such delivery or transmission; or
    - ii. In the case of nationally recognized overnight courier, on the next business day after the date sent; or
    - iii. In the case of mailing, on the third business day following posting.
3. **Environmental Review.** 24 CFR Part 58 prohibits the commitment or expenditure of HUD funds until the environmental review process has been completed and the subrecipient receives an "Ability to Obligate and Incur Costs" notice from the County. Subrecipients may not spend either public or private project funds (HUD, other Federal or nonfederal funds), or execute a legally binding agreement for property acquisition, rehabilitation, conversion, repair, or construction pertaining to a specific site until environmental clearance has been achieved. Subrecipients must avoid any and all actions that would preclude the selection of alternative choices before a final decision is made – that decision being based upon an understanding of the environmental consequences and actions that can protect, restore, and enhance the human environment (i.e., the natural, physical, social, and economic environment). Activities that have physical impacts or which

limit the choice of alternatives cannot be undertaken, even with the subrecipient's or other project participant's own funds, prior to obtaining environmental clearance.

Obligated and/or incurred project funds prior to the completion of all required local, state, and federal environmental laws will jeopardize the project's eligibility to receive federal funds. Under federal law, the County of San Luis Obispo is not responsible for the award of funds nor the reimbursement of any project funds to the applicant/subrecipient and the County will reallocate the funds to another eligible project and applicant.

4. **Independent Contractor.** Nothing contained in this Agreement is intended to, or shall be construed in any manner, as creating or establishing the relationship of employer/employee between the parties. The Subrecipient shall at all times remain an "independent contractor" with respect to the services to be performed under this Agreement. The Recipient shall be exempt from payment of all Unemployment Compensation, FICA, retirement, life and/or medical insurance and Workers' Compensation Insurance, as the Subrecipient is an independent contractor.
5. **Indemnification.** To the fullest extent permitted by law, Subrecipient shall indemnify, defend, and hold harmless the County and its officers, agents, employees, and volunteers from and against all claims, demands, damages, liabilities, loss, costs, and expense (including attorney's fees and costs of litigation) of every nature arising out of or in connection with Subrecipient's performance or attempted performance of any obligation or duty provided for or relating to this Agreement, except such loss or damage which was caused by sole negligence or willful misconduct of the County.
6. **Recipient Recognition.** The Subrecipient shall insure recognition of the role of the Recipient in providing services through this Agreement. All activities, facilities and items utilized pursuant to this Agreement shall be prominently labeled as to funding source. In addition, the Subrecipient will include a reference to the support provided herein in all publications made possible with funds made available under this Agreement.
7. **Severability.** If any provision of this Agreement is held invalid, the remainder of the Agreement shall not be affected thereby, and all other parts of this Agreement shall nevertheless be in full force and effect.
8. **Section Headings and Subheadings.** Section headings and subheadings contained in this Agreement are included for convenience only and shall not limit or otherwise affect the terms of this Agreement.
9. **Waiver.** The Recipient's failure to act with respect to a breach by the Subrecipient does not waive its right to act with respect to subsequent or similar breaches. The failure of the Recipient to exercise or enforce any right or provision shall not constitute a waiver of such right or provision.
10. **Entire Agreement.** This agreement constitutes the entire agreement between the Recipient and the Subrecipient for the use of funds received under this Agreement and it supersedes all prior or contemporaneous communications and proposals, whether electronic, oral, or written between the Recipient and the Subrecipient with respect to this Agreement.
11. **Amendments.** The Recipient or Subrecipient may amend this Agreement at any time provided that such amendments make specific reference to this Agreement, and are executed in writing, signed by a duly authorized representative of each organization, and approved by the Recipient's governing body. Such amendments shall not invalidate this Agreement, nor relieve or release the Recipient or Subrecipient from its obligations under this Agreement.  
The Recipient may, in its discretion, amend this Agreement to conform with Federal, state, or local governmental guidelines, policies and available funding amounts, or for other reasons. If such amendments result in a change in the funding, the scope of services, or schedule of the activities to be undertaken as part of this Agreement, such modifications will be incorporated only by written amendment signed by both Recipient and Subrecipient.
12. **Suspension or Termination.** In accordance with 24 CFR 85.43, the Recipient may suspend or terminate this Agreement if the Subrecipient materially fails to comply with any terms of this Agreement, which include (but are not limited to) the following:

- a. Failure to comply with any of the rules, regulations or provisions referred to herein, or such statutes, regulations, executive orders, and HUD guidelines, policies or directives as may become applicable at any time;
- b. Failure, for any reason, of the Subrecipient to fulfill in a timely and proper manner its obligations under this Agreement;
- c. Ineffective or improper use of funds provided under this Agreement; or
- d. Submission by the Subrecipient to the Recipient reports that are incorrect or incomplete in any material respect.

In accordance with 24 CFR 85.44, this Agreement may also be terminated for convenience by either the Recipient or the Subrecipient, in whole or in part, by setting forth the reasons for such termination, the effective date, and, in the case of partial termination, the portion to be terminated. However, if in the case of a partial termination, the Recipient determines that the remaining portion of the award will not accomplish the purpose for which the award was made, the Recipient may terminate the award in its entirety.

**13. Insurance & Bonding.** Subrecipient shall procure and maintain for the duration of the agreement insurance against claims for injuries to persons or damages to property which may arise from or in connection with the performance of the work hereunder by the Subrecipient, its agents, representatives, or employees.

- a. **Minimum Scope and Limit of Insurance.** Coverage shall be at least as broad as:
  - i. **Commercial General Liability (CGL):** Insurance Services Office (ISO) Form CG 00 01 covering CGL on an "occurrence" basis for bodily injury and property damage, including products-completed operations, personal injury and advertising injury, with limits no less than one million dollars (**\$1,000,000**) per occurrence. If a general aggregate limit applies, either the general aggregate limit shall apply separately to this project/location or the general aggregate limit shall be twice the required occurrence limit.
  - ii. **Automobile Liability.** ISO Form Number CA 0001 covering, Code 1 (any auto), or if Subrecipient has no owned autos, Code 8 (hired) and 9 (non-owned), with limit no less than one million dollars (**\$1,000,000**) per accident for bodily injury and property damage.
  - iii. **Workers' Compensation** insurance as required by the State of California, with Statutory Limits, and Employer's Liability Insurance with limit of no less than one million dollars (**\$1,000,000**) per accident for bodily injury or disease. If Subrecipient will provide leased employees, or, is an employee leasing or temporary staffing firm or a professional employer organization (PEO), coverage shall also include an Alternative Employer endorsement (providing scope of coverage equivalent to ISO policy form WC 00 03 01 A) naming the County as the Alternate Employer and the endorsement form shall be modified to provide that County will receive not less than thirty (30) days advance written notice of cancellation of this coverage provision. If applicable to Subrecipient's operations, coverage also shall be arranged to satisfy the requirements of any federal workers or workmen's compensation law or any federal occupational disease law. If the Subrecipient maintains higher limits than the minimums shown above, the County requires and shall be entitled to coverage for the higher limits maintained by the Subrecipient.
  - iv. **Professional Liability/Errors and Omissions.** Insurance covering Subcontractor's liability arising from or related to this Agreement, with limits of not less than one million dollars (\$1,000,000) per claim and two million dollars (\$2,000,000) aggregate. Further, Subrecipient understands and agrees it shall maintain such coverage for a period of not less than three (3) years following this Agreement's expiration, termination, or cancellation.

- b. **Additional Insured Status.** The County, its officers, officials, employees, and volunteers are to be covered as insureds on the auto policy with respect to liability arising out of automobiles owned, leased, hired or borrowed by or on behalf of the Subrecipient; and on the CGL policy with respect to liability arising out of work or operations performed by or on behalf of the Subrecipient including materials, parts, or equipment furnished in connection with such work or operations. General liability coverage can be provided in the form of an endorsement to the Subrecipient's insurance (at least as broad as ISO Form CG 20 10, 11 85 or both CG 20 10 and CG 23 37 forms if later revisions used).
- i. **Primary Coverage.** For any claims related to this contract, the Subrecipient's insurance coverage shall be primary insurance as respects the County, its officers, officials, employees, and volunteers. Any insurance or self-insurance maintained by the County, its officers, officials, employees, or volunteers shall be excess of the Subrecipient's insurance and shall not contribute with it.
  - ii. **Notice of Cancellation.** Each insurance policy required above shall state that **coverage shall not be canceled, except after thirty (30) days' prior written notice** (ten (10) days for non-payment) has been given to the County.
  - iii. **Failure to Maintain Insurance.** Subrecipient's failure to maintain or to provide acceptable evidence that it maintains the required insurance shall constitute a material breach of the Agreement, upon which the County immediately may withhold payments due to Subrecipients, and/or suspend or terminate this Agreement. The County, at its sole discretion, may obtain damages from Subrecipient resulting from said breach.
  - iv. **Waiver of Subrogation.** Subrecipient hereby grants to County a waiver of any right to subrogation which any insurer of said Subrecipient may acquire against the County by virtue of the payment of any loss under such insurance. Subrecipient agrees to obtain any endorsement that may be necessary to affect this waiver of subrogation, but this provision applies regardless of whether the County has received a waiver of subrogation endorsement for the insurer.
  - v. **Deductibles and Self-Insured Retentions.** Any deductibles or self-insured retentions must be declared to and approved by the County. The County may require the Subcontractor to provide proof of ability to pay losses and related investigation, claim administration, and defense expenses within the retention.
  - vi. **Acceptability of Insurers.** Insurance is to be placed with insurers with a current A.M. Best's rating of no less than A: VII, unless otherwise acceptable to the County.
  - vii. **Claims Made Policies.** If any of the required policies provide coverage on a claims-made basis:
    1. The Retroactive Date must be shown and must be before the date of the agreement or the beginning of agreement work.
    2. Insurance must be maintained, and evidence of insurance must be provided **for at least five (5) years after completion of the agreement of work.**
    3. If coverage is canceled or non-renewed, and not **replaced with another claims-made policy form with a Retroactive Date** prior to the agreement effective date, the Subrecipient must purchase "extended reporting" coverage for a minimum of **five (5) years** after completion of agreement work.
  - viii. **Separation of Insureds.** All liability policies shall provide cross-liability coverage as would be afforded by the standard ISO (Insurance Services Office, Inc.) separation of insureds provision with no insured versus insured exclusions or limitation.
  - ix. **Verification of Coverage.** Subrecipient shall furnish the County with original certification and amendatory endorsements, or copies of the applicable policy language effecting coverage required by this clause. All certificates and endorsements

are to be received and approved by the County before work commences. However, failure to obtain the required documents prior to the work beginning shall not waive the Subrecipient's obligation to provide them. The County reserves the right to require complete, certified copies of all required insurance policies, including endorsements required by these specifications, at any time.

- x. **Certificates and copies** of any required endorsements shall be sent to:  
Marge Castle, Program Manager  
County of San Luis Obispo  
Department of Social Services  
P.O. Box 8119  
San Luis Obispo, CA 93403-8119
- xi. **Subcontractors:** Subrecipient shall require and verify that all subcontractors maintain insurance meeting all the requirements stated herein.
- xii. **Special Risks or Circumstances:** County reserves the right to modify these requirements, including limits, based on the nature of the risk, prior experience, insurer, coverage, or other special circumstances.

#### 14. Uniform Administrative Requirements

- a. **Compliance.** Pursuant to 24 CFR 570.502, the Subrecipient will comply with the requirements of 2 CFR part 200, except that the following provisions shall not apply: § 200.305 as modified by 24 CFR 570.502(a)(1), 200.306, 200.307 as governed by 24 CFR 570.504, 200.308, 200.311 except as provided in 24 CFR 570.200(j) and governed by 24 CFR 570.505, 200.313 except as provided in 570.502(a)(6), 200.333 except as provided in 570.502(a)(7)(ii) for subrecipients. If there is a conflict between definitions in 2 CFR part 200 and 24 CFR part 570, the definitions in 24 CFR part 570 shall govern.
- b. **Subpart K of 24 CFR Part 570.** The Subrecipient agrees to carry out each activity in compliance with all Federal laws and regulations described in subpart K of these regulations, except that:
  - i. The Subrecipient does not assume the recipient's environmental responsibilities described at 570.604; and
  - ii. The Subrecipient does not assume the recipient's responsibility for initiating the review under the provisions of 24 CFR Part 52.
- c. **Agreement Responsibility for Monitoring and Records.** HUD, the Office of the Inspector General (OIG), and the designated representatives of the Subrecipient, and other appropriate officials shall have access to all personnel records, management information, and fiscal data of the Subrecipient and any agency or contractor with whom the Subrecipient executes a subcontract necessary to carry out any CDBG program(s) for monitoring purposes (2 CFR Part 200.328, 200.327 and 200.326). The Subrecipient shall respond in a timely manner to all identified corrective action needs as a result of HUD, Recipient, or other monitoring. The Subrecipient shall submit to Recipient all required reports and monitoring corrective action plans on a timely basis, as delineated by the Recipient. Records shall be maintained as follows:
  - i. The Subrecipient agrees to retain all pertinent records under CDBG program, including financial records, until advised by the Recipient that further retention is unnecessary. Generally, records shall be retained for a period for five (5) years from the end of the fiscal year in which the last project covered by the Recipient's annual agreement with HUD is completed. Records shall be open and available for inspection by auditors and/or other staff assigned by HUD and/or the Recipient during the normal business hours of the Subrecipient. If at the end of such five (5) year period, there is ongoing litigation, claims, negotiations, audit, or other action involving the Subrecipient's or the Recipient's records, which has started before expiration of the five (5) year period, the



Subrecipient will retain the records until the completion of the action and resolution of all issues which arise from it as stated in 2 CFR Part 200.333.

- ii. Consistent with applicable state and local laws regarding privacy and obligations of confidentiality, the Subrecipient shall furnish and cause each of its own subrecipients or subcontractors to furnish all information and reports required hereunder and will permit access to its books, records and accounts to the Recipient, HUD or its agent, or other authorized Federal officials for purposes of investigation to ascertain compliance with the rules, regulations and provisions stated herein. The Subrecipient also must provide citizens with reasonable access to records on the past use of CDBG funds (24 CFR 570.508).
- iii. Records for nonexpendable property shall be retained for a period of five (5) years after final disposition of the property, if applicable.

**15. Financial Management.**

- a. **Accounting Standards.** The Subrecipient agrees to comply with 24 CFR 84.21–28 and agrees to adhere to the accounting principles and procedures required therein, utilize adequate internal controls, and maintain necessary source documentation for all costs incurred.
- b. **Cost Principles.** The Subrecipient shall administer its program in conformance with OMB Circulars A-122, “Cost Principles for Non-Profit Organizations,” or A-21, “Cost Principles for Educational Institutions,” as applicable. These principles shall be applied for all costs incurred whether charged on a direct or indirect basis.

**16. Conflict of Interest.** The Subrecipient agrees to abide by the provisions of 24 CFR 84.42 and 570.611, which include (but are not limited to) the following:

- a. The Subrecipient shall maintain a written code or standards of conduct that shall govern the performance of its officers, employees or agents engaged in the award and administration of contracts supported by Federal funds.
- b. No employee, officer, or agent of the Subrecipient shall participate in the selection, or in the award, or administration of, a contract supported by Federal funds if a conflict of interest, real or apparent, would be involved.
- c. No covered persons who exercise or have exercised any functions or responsibilities with respect to CDBG-assisted activities, or who are in a position to participate in a decision-making process or gain inside information with regard to such activities, may obtain a financial interest in any contract, or have a financial interest in any contract, subcontract, or agreement with respect to the CDBG-assisted activity, or with respect to the proceeds from the CDBG-assisted activity, either for themselves or those with whom they have business or immediate family ties, during their tenure or for a period of one (1) year thereafter. For purposes of this paragraph, a “covered person” includes any person who is an employee, agent, consultant, officer, or elected or appointed official of the Recipient, the Subrecipient, or any designated public agency.

**17. Lobbying.** The Subrecipient hereby certifies that:

- a. No Federal appropriated funds have been paid or will be paid, by or on behalf of it, to any person for influencing or attempting to influence an officer or employee of any agency, a Member of Congress, an officer or employee of Congress, or an employee of a Member of Congress in connection with the awarding of any Federal contract, the making of any Federal grant, the making of any Federal loan, the entering into of any cooperative agreement, and the extension, continuation, renewal, amendment, or modification of any Federal contract, grant, loan, or cooperative agreement.
- b. If any funds other than Federal appropriated funds have been paid or will be paid to any person for influencing or attempting to influence an officer or employee of any agency, a Member of Congress, an officer or employee of Congress, or an employee of a Member of Congress in connection with this Federal contract, grant, loan, or cooperative agreement,

it will complete and submit Standard Form-LLL, "Disclosure Form to Report Lobbying," in accordance with its instructions; and

- c. It will require that the language of paragraph (d) of this certification be included in the award documents for all subawards at all tiers (including subcontracts, subgrants, and contracts under grants, loans, and cooperative agreements) and that all Subrecipients shall certify and disclose accordingly.
- d. Lobbying Certification: This certification is a material representation of fact upon which reliance was placed when this transaction was made or entered into. Submission of this certification is a prerequisite for making or entering into this transaction imposed by section 1352, title 31, U.S.C. Any person who fails to file the required certification shall be subject to a civil penalty of not less than ten thousand dollars (\$10,000) and not more than one hundred thousand dollars (\$100,000) for each such failure.

**18. Religious Activities.** The Subrecipient agrees that funds provided under this Agreement will not be utilized for inherently religious activities prohibited by 24 CFR 570.200(j), such as worship, religious instruction, or proselytization.

**19. Copyright.** If this contract results in any copyrightable material or inventions, the Recipient and/or grantor agency reserves the right to royalty-free, non-exclusive, and irrevocable license to reproduce, publish or otherwise use and to authorize others to use, the work or materials for governmental purposes.

**EXHIBIT E**  
**SPECIAL CONDITIONS**

**1. Administrative Requirements**

**a. Documentation and Record Keeping.**

1. **Records to be Maintained.** The Subrecipient shall maintain all records required by the Federal regulations specified in 24 CFR 570.506, that are pertinent to the activities to be funded under this Agreement. Such records shall include but not be limited to:
  1. Records providing a full description of each activity undertaken;
  2. Records demonstrating that each activity undertaken meets one of the National Objectives of the CDBG program;
  3. Records required to determine the eligibility of activities;
  4. Records required to document the acquisition, improvement, use or disposition of real property acquired or improved with CDBG assistance;
  5. Records documenting compliance with the fair housing and equal opportunity components of the CDBG program;
  6. Financial records as required by 24 CFR 570.502, and 24 CFR 84.21-28; and
  7. Other records necessary to document compliance with Subpart K of 24 CFR Part 570.
2. **Retention.** The Subrecipient shall retain all financial records, supporting documents, statistical records, and all other records pertinent to the Agreement for a period of five (5) years. The retention period begins on the date of the submission of the Recipient's annual performance and evaluation report to HUD in which the activities assisted under the Agreement are reported on for the final time.
3. **Client Data.** The Subrecipient shall maintain client data demonstrating client eligibility for services provided. Such data shall include, but not be limited to, client identifier, address, income level or other basis for determining eligibility, and description of service provided. Such information shall be made available to Recipient monitors or their designees for review upon request.
4. **Disclosure.** The Subrecipient understands that client information collected under this contract is private and the use or disclosure of such information, when not directly connected with the administration of the Recipient's or Subrecipient's responsibilities with respect to services provided under this contract, is prohibited unless written consent is obtained from such person receiving service and, in the case of a minor, that of a responsible parent/guardian.
5. **Close-outs.** The Subrecipient's obligation to the Recipient shall not end until all close-out requirements are completed. Activities during this close-out period shall include, but are not limited to, making final payments, disposing of program assets (including the return of all unused materials, equipment, unspent cash advances, program income balances, and accounts receivable to the Recipient), and determining the custodianship of records. Notwithstanding the foregoing, the terms of this Agreement shall remain in effect during any period that the Subrecipient has control over CDBG funds, including program income.
6. **Audits & Inspections.** All Subrecipient records with respect to any matters covered by this Agreement shall be made available to the Recipient, grantor agency, and the Comptroller General of the United States or any of their authorized representatives, at any time during normal business hours, as often as deemed necessary, to audit, examine, and make excerpts or transcripts of all relevant data. Any deficiencies noted in audit reports must be fully cleared by the Subrecipient within thirty (30) days after receipt by the Subrecipient. Failure of the Subrecipient to comply with the above audit requirements will constitute a violation of this contract and may result in the withholding of future payments. The Subrecipient hereby agrees to have an annual agency audit

conducted in accordance with current Recipient policy concerning subrecipient audits and OMB Circular A-133.

2. **Reporting and Payment Procedures.**

- a. **Program Income.** The use of program income by the Subrecipient shall comply with the requirements set forth at 24 CFR 570.504.
- b. **Indirect Costs.** If indirect costs are charged, the Subrecipient will develop an indirect cost allocation plan for determining the appropriate Subrecipient's share of administrative costs and shall submit such plan to the Recipient for approval, in a form specified by the Recipient.
- c. **Payment Procedures.** The Recipient will pay to the Subrecipient funds available under this Agreement based upon information submitted by the Subrecipient and consistent with any approved budget and Recipient policy concerning payments. Payments will be made for eligible expenses actually incurred by the Subrecipient, and not to exceed actual award amount. The Recipient shall pay Subrecipient within thirty (30) days of receipt of a complete payment request.
- d. **Progress Reports.** The Subrecipient shall submit regular Progress Reports to the Recipient in the form, content, and frequency as required by the Recipient, set forth in Exhibit A.
- e. **Use and Reversion of Assets.** The use and disposition of real property and equipment under this Agreement shall be in compliance with the requirements of 24 CFR Part 84 and 24 CFR 570.502, 570.503, and 570.504, as applicable, which include but are not limited to the following:
  - i. The Subrecipient shall transfer to the Recipient any CDBG funds on hand and any accounts receivable attributable to the use of funds under this Agreement at the time of expiration, cancellation, or termination. Real property under the Subrecipient's control that was acquired or improved, in whole or in part, with funds under this Agreement in excess of twenty-five thousand dollars (\$25,000) shall be used to meet one of the CDBG National Objectives pursuant to 24 CFR 570.208 until five (5) years after expiration of this Agreement. If the Subrecipient fails to use CDBG-assisted real property in a manner that meets a CDBG National Objective for the prescribed period of time, the Subrecipient shall pay the Recipient an amount equal to the current fair market value of the property less any portion of the value attributable to expenditures of non-CDBG funds for acquisition of, or improvement to, the property. Such payment shall constitute program income to the Recipient. The Subrecipient may retain real property acquired or improved under this Agreement after the expiration of the five (5) year period.
  - ii. In all cases in which equipment acquired, in whole or in part, with funds under this Agreement is sold, the proceeds shall be program income (prorated to reflect the extent to funds received under this Agreement were used to acquire the equipment). Equipment not needed by the Subrecipient for activities under this Agreement shall be (a) transferred to the Recipient for the CDBG program or (b) retained after compensating the Recipient [an amount equal to the current fair market value of the equipment less the percentage of non-CDBG funds used to acquire the equipment].

3. **Civil Rights.**

- a. **Compliance.** The Subrecipient agrees to comply with local and state civil rights ordinances and with Title VI of the Civil Rights Act of 1964 as amended, Title VIII of the Civil Rights Act of 1968 as amended, Section 104(b) and Section 109 of Title I of the Housing and Community Development Act of 1974 as amended, Section 504 of the Rehabilitation Act of 1973, the Americans with Disabilities Act of 1990, the Age Discrimination Act of 1975, Executive Order 11063, and Executive Order 11246 as amended by Executive Orders 11375, 11478, 12107 and 12086.

- b. **Nondiscrimination.** The Subrecipient agrees to comply with the non-discrimination in employment and contracting opportunities laws, regulations, and executive orders referenced in 24 CFR 570.607, as revised by Executive Order 13279. The applicable non-discrimination provisions in Section 109 of the HCDA are still applicable.
  - c. **Land Covenants.** This contract is subject to the requirements of Title VI of the Civil Rights Act of 1964 (P. L. 88-352) and 24 CFR 570.601 and 570.602. In regard to the sale, lease, or other transfer of land acquired, cleared or improved with assistance provided under this contract, the Subrecipient shall cause or require a covenant running with the land to be inserted in the deed or lease for such transfer, prohibiting discrimination as herein defined, in the sale, lease or rental, or in the use or occupancy of such land, or in any improvements erected or to be erected thereon, providing that the Recipient and the United States are beneficiaries of and entitled to enforce such covenants. The Subrecipient, in undertaking its obligation to carry out the program assisted hereunder, agrees to take such measures as are necessary to enforce such covenant, and will not itself so discriminate.
  - d. **Section 504.** The Subrecipient agrees to comply with all Federal regulations issued pursuant to compliance with Section 504 of the Rehabilitation Act of 1973 (29 U.S.C. 794), which prohibits discrimination against the individuals with disabilities or handicaps in any Federally assisted program. The Recipient shall provide the Subrecipient with any guidelines necessary for compliance with that portion of the regulations in force during the term of this Agreement.
  - e. **Subcontract Provisions.** The Subrecipient will include the provisions of Civil Rights, and Affirmative Action, in every subcontract or purchase order, specifically or by reference, so that such provisions will be binding upon each of its own subrecipients or subcontractors.
4. **Affirmative Action.**
- a. **Women- and Minority-Owned Businesses (W/MBE).** The Subrecipient will use its best efforts to afford small businesses, minority business enterprises, and women's business enterprises the maximum practicable opportunity to participate in the performance of this contract. As used in this contract, the terms "small business" means a business that meets the criteria set forth in section 3(a) of the Small Business Act, as amended (15 U.S.C. 632), and "minority and women's business enterprise" means a business at least fifty-one (51) percent owned and controlled by minority group members or women.
5. **Labor Standards.** The Labor Standards Regulations set forth in Section 570.603 of 24 CFR Part 570; and HUD Handbook 1344.1. If this Agreement involves construction or facility improvements exceeding two thousand dollars (\$2,000) awarded by the Recipient, the Subrecipient agrees to comply with:
- a. **Prevailing Wages.** Subrecipient shall comply with the prevailing wage requirements of the Secretary of Labor in accordance with the Davis-Bacon Act (40 USC 276a to 276 a-7) as supplemented in the Department of Labor regulations (29 CFR Part 5). These requirements shall apply to all contracts, financed in whole or in part with assistance provided under this Agreement, that exceed two thousand dollars (\$2,000) and involve construction, renovation, or repair of any building or work. These requirements shall not apply to contracts the exceed two thousand dollars (\$2,000) that involve the rehabilitation of residential property containing less than eight (8) households, or as allowed by the Housing and Community Development Act of 1974, as amended. Contractors shall also comply regulations under 29 CFR, Parts 3, 1, 5 and 7 governing the payment of wages for apprentices and trainees to journeymen. However, if wage rates higher than those required under the regulations are imposed by state or local law, nothing hereunder is intended to relieve the Subrecipient of its obligation, if any, to require payment of the higher wage. The Subrecipient shall cause or require to be inserted in full, in all such contracts subject to such regulations, provisions meeting the requirements of this paragraph, for such contracts in excess of ten thousand dollars (\$10,000).

- b. **Copeland Anti-Kickback Act.** During the performance of this Agreement, the Subrecipient and its contractors and subcontractors agree to comply with the Copeland Anti-Kickback Act (18 USC 874) as supplemented in the Department of labor regulations (29 CFR Part 3). This act provides that the Subrecipient, its contractor and subcontractors shall be prohibited from inducing any person employed in the construction, completion, or repair of public facilities to give up any part of the compensation which they are otherwise entitled.

The Subrecipient, its contractor and subcontractors shall maintain documentation that demonstrates compliance with hour and wages requirements of this part. Such documentation shall be made available to the Recipient for review upon request. The Subrecipient's contractor and subcontractors agree to include a provision requiring such compliance in its lower tier covered contracts and transactions.

Agreements exceeding one hundred thousand dollars (\$100,000) that involve the employment of mechanics or laborers shall comply with the following:

- a. **Contract Work Hours and Safety Standards Act.** Where applicable, during the performance of this Agreement all contracts awarded by the Subrecipient, the prime contractor and subcontractors in excess of two thousand dollars (\$2,000) for construction contracts and in excess of one hundred thousand dollars (\$100,000) are required, pursuant to the Contract Work Hours and Safety Standards Act, to apply the four clauses below. These clauses shall be inserted in addition to the clauses required by 29 CFR Part 5.5(a) or 29 CFR Part 4.6. As used in this section, the terms laborers and mechanics include watchmen and guards.
- i. **Overtime requirements.** No contractor or subcontractor contracting for any part of the contract work which may require or involve the employment of laborers or mechanics shall require or permit any such laborer or mechanic in any workweek in which he or she is employed on such work to work in excess of forty (40) hours in such workweek unless such laborer or mechanic receives compensation at a rate not less than one and one-half (1.5) times the basic rate of pay for all hours worked in excess of forty (40) hours in such workweek.
  - ii. **Violation; liability for unpaid wages; liquidated damages.** In the event of any violation of the clause set forth in paragraph (a.) of this section, the contractor, and any subcontractor responsible therefore shall be liable for the unpaid wages. In addition, such contractor and subcontractor shall be liable to the United States (in the case of work done under contract for the District of Columbia or a territory, to such District or to such territory), for liquidated damages. Such liquidated damages shall be computed with respect to each individual laborer or mechanic, including watchmen and guards, employed in violation of the clause set forth in paragraph (a.) of this section, in the sum of ten dollars (\$10) for each calendar day on which such individual was required or permitted to work in excess of the standard workweek of forty (40) hours without payment of the overtime wages required by the clause set forth in paragraph (a.) of this section.
  - iii. **Withholding for unpaid wages and liquidated damages.** The Recipient shall upon its own action or upon written request of an authorized representative of the U.S. Department of Housing and Urban Development (HUD) or the U.S. Department of Labor (DOL) withhold or cause to be withheld, from any moneys payable on account of work performed by the contractor or subcontractor under any such contract or any other federal contract with the same prime contractor, or any other federally-assisted contract subject to the Contract Work Hours and Safety Standards Act, which is held by the same prime contractor, such sums as may be determined to be necessary to satisfy any liabilities of such contractor or subcontractor for unpaid wages and liquidated damages as provided in the clause set forth in paragraph (ii.) of this section.
  - iv. **Subcontracts.** The contractor or subcontractor shall insert in any subcontracts the clauses set forth in paragraphs (i.) through (iv.) of this section and a clause requiring the subcontractors

to include these clauses in any lower tier subcontracts. The prime contractor shall be responsible for compliance by any subcontractor or lower tier subcontractor with the clauses set forth in paragraphs (i.) through (iv.) of this section.

**6. Bonding Requirements.** For construction or facility improvements contracts or subcontracts exceeding the Simplified Acquisition Threshold of one hundred fifty thousand dollars (\$150,000) the Recipient may accept the bonding policy and requirements of the Subrecipient provided that the Recipient has made a determination that the CDBG funds are adequately protected. If such a determination has not been made, the minimum requirements must be as follows:

- a. **Bid Guarantee.** At the submission of a bid to the Subrecipient, the contractor shall furnish a "bid" guarantee equivalent to five percent (5%) of the bid price. The "bid guarantee" must consist of a firm commitment such as a bid bond, certified check, or other negotiable instrument accompanying a bid as assurance that the bidder will, upon acceptance of the bid, execute such contractual documents as may be required within the time specified.
- b. **Performance Bond.** At the time of execution of a contract between the Subrecipient and the contractor, the contractor shall furnish a "faithful performance" bond in the sum of one hundred percent (100%) of the contract price to guarantee the performance of the contract.
- c. **Payment Bond.** At the time of execution of the contract, the contractor shall furnish a "payment" bond in the sum of one hundred percent (100%) of the contract price to assure payment as required by law of all persons supplying labor and material in the execution of the work provided for in the contract.

**7. Section 3.** Economic Opportunities for Low- and Very Low-Income Persons (24 CFR Part 75). A project receiving HUD assistance of at least two hundred thousand dollars (**\$200,000**) involving construction, demolition, or rehabilitation is required to comply with Section 3 of the Housing and Urban Development Act of 1968, as amended, 12 U.S.C. 1701u (Section 3 Final Rule). hereinafter referred to as "Section 3".

The purpose of the Section 3 is to ensure that employment and other economic opportunities generated by the U.S. Department of Housing and Urban Development (HUD) assistance shall, to the greatest extent feasible, be directed to low and very low-income persons within the project area or to Business Concerns located in or owned in substantial part by persons residing within the area of the project (Section 3 Workers and/or Section 3 Business Concerns). Income limits defined by Section 3(b)(2) of the Housing Act of 1937.

- a. **Recordkeeping.** HUD shall have access to all records, reports, and other documents or items of the recipient that are maintained to demonstrate compliance with the requirements of this part, or that are maintained in accordance with the regulations governing the specific HUD program by which the Section 3 project is governed.

Subrecipients must maintain documentation to ensure that workers meet the definition of a Section 3 worker or Targeted Section 3 worker, at the time of hire or the first reporting period.

- b. The Subrecipient shall insure that all contracts subject to Section 3 include the following:
  - i. The Parties to this contract agree to comply with the Section 3 provisions set forth in 24 CFR Part 75. The parties to this contract certify that they are under no contractual or other impediments that would prevent them from complying with the Part 75 regulations.
  - ii. The contractor agrees to send to each labor organization or representative of workers with which the contractor has a collective bargaining agreement or other understanding, if any, a notice advising the labor organization or workers' representative of the contractor's commitments under this Section 3 clause and will post copies of the notice in conspicuous places at the work site where both employees and applicants for training and employment positions can see the notice. The notice shall describe the Section 3 preference, shall set forth minimum number and job titles subject to hire, availability of apprenticeship and training positions, the qualifications for each; and the name and location of the person(s) taking applications for each of the positions; and the anticipated date the work shall begin.
  - iii. The contractor agrees to include this Section 3 language in every subcontract subject to compliance with regulation in 24 CFR Part 75, and agrees to take appropriate action, as provided in an applicable provision of the subcontract or in this Section 3 language, upon

a finding that the subcontractor is in violation of the regulation in 24 CFR Part 75 and the associated policies and guidelines. The contractor will not subcontract with any subcontractor where the contractor has notice or knowledge that the subcontractor has been found in violation of the regulation in 24 CFR Part 75.

- iv. The contractor will certify that any vacant employment positions, including training positions, that are filled (1) after the contractor is selected but before the contract is executed, and (2) with persons other than those to whom the regulations of 24 CFR Part 135 require employment opportunities to be directed, were not filled to circumvent the contractor's obligations under 24 CFR Part 135.
- v. Noncompliance with 24 CFR Part 75 and the associated policies and guidelines may result in sanctions specified by 24 CFR 75, termination of this contract for default, or debarment or suspension from future HUD-assisted contracts.
- c. **Subcontracts.** The Subrecipient will include this Section 3 clause in every subcontract and will take appropriate action pursuant to the subcontract upon a finding that the subcontractor is in violation of regulations issued by the grantor agency. The Subrecipient will not subcontract with any entity where it has notice or knowledge that the latter has been found in violation of regulations under 24 CFR Part 135 and will not let any subcontract unless the entity has first provided it with a preliminary statement of ability to comply with the requirements of these regulations.
8. **Access to Records.** The Subrecipient shall furnish and cause each of its own subrecipients or subcontractors to furnish all information and reports required hereunder and will permit access to its books, records and accounts by the Recipient, HUD or its agent, or other authorized Federal officials for purposes of investigation to ascertain compliance with the rules, regulations and provisions stated herein.
9. **Equal Employment Opportunity and Affirmative Action (EEO/AA) Statement.** The Subrecipient will, in all solicitations or advertisements for employees placed by or on behalf of the Subrecipient, state that it is an Equal Opportunity or Affirmative Action employer.
10. **Employment Restrictions.** The Subrecipient is prohibited from using funds provided herein or personnel employed in the administration of the program for: political activities; inherently religious activities; lobbying; political patronage; and nepotism activities.
11. **Conduct.**
  - a. **Assignability.** The Subrecipient shall not assign or transfer any interest in this Agreement without the prior written consent of the Recipient thereto; provided, however, that claims for money due or to become due to the Subrecipient from the Recipient under this contract may be assigned to a bank, trust company, or other financial institution without such approval. Notice of any such assignment or transfer shall be furnished promptly to the Recipient.
  - b. **Subcontracts**
    - i. **Approvals**  
The Subrecipient shall not enter into any subcontracts with any agency or individual in the performance of this contract without the written consent of the Recipient prior to the execution of such agreement.
    - ii. **Monitoring**  
The Subrecipient will monitor all subcontracted services on a regular basis to assure contract compliance. Results of monitoring efforts shall be summarized in written reports and supported with documented evidence of follow-up actions taken to correct areas of noncompliance.
    - iii. **Content**  
The Subrecipient shall cause all of the provisions of this contract in its entirety to be included in and made a part of any subcontract executed in the performance of this Agreement.
    - iv. **Selection Process**  
The Subrecipient shall undertake to ensure that all subcontracts let in the performance of this Agreement shall be awarded on a fair and open competition basis in accordance with



applicable procurement requirements. Executed copies of all subcontracts shall be forwarded to the Recipient along with documentation concerning the selection process.

12. **Hatch Act.** The Subrecipient agrees that no funds provided, nor personnel employed under this Agreement, shall be in any way or to any extent engaged in the conduct of political activities in violation of Chapter 15 of Title V of the U.S.C.

13. **Environmental Conditions**

- a. **Air and Water.** The Subrecipient agrees to comply with the following requirements insofar as they apply to the performance of this Agreement:
  - i. Clean Air Act, 42 U.S.C., 7401, et seq.;
  - ii. Federal Water Pollution Control Act, as amended, 33 U.S.C., 1251, et seq., as amended, 1318 relating to inspection, monitoring, entry, reports, and information, as well as other requirements specified in said Section 114 and Section 308, and all regulations and guidelines issued thereunder;
  - iii. Environmental Protection Agency (EPA) regulations pursuant to 40 CFR Part 50, as amended.
- b. **Flood Disaster Protection.** In accordance with the requirements of the Flood Disaster Protection Act of 1973 (42 U.S.C. 4001), the Subrecipient shall assure that for activities located in an area identified by the Federal Emergency Management Agency (FEMA) as having special flood hazards, flood insurance under the National Flood Insurance Program is obtained and maintained as a condition of financial assistance for acquisition or construction purposes (including rehabilitation).
- c. **Lead-Based Paint.** The Subrecipient agrees that any construction or rehabilitation of residential structures with assistance provided under this Agreement shall be subject to HUD Lead-Based Paint Regulations at 24 CFR 570.608, and 24 CFR Part 35, Subpart B. Such regulations pertain to all CDBG-assisted housing and require that all owners, prospective owners, and tenants of properties constructed prior to 1978 be properly notified that such properties may include lead-based paint. Such notification shall point out the hazards of lead-based paint and explain the symptoms, treatment and precautions that should be taken when dealing with lead-based paint poisoning and the advisability and availability of blood lead level screening for children under seven (7) years old. The notice should also point out that if lead-based paint is found on the property, abatement measures may be undertaken. The regulations further require that, depending on the amount of Federal funds applied to a property, paint testing, risk assessment, treatment and/or abatement may be conducted.
- d. **Historic Preservation.** The Subrecipient agrees to comply with the Historic Preservation requirements set forth in the National Historic Preservation Act of 1966, as amended (16 U.S.C. 470) and the procedures set forth in 36 CFR Part 800, Advisory Council on Historic Preservation Procedures for Protection of Historic Properties, insofar as they apply to the performance of this agreement.

In general, this requires concurrence from the State Historic Preservation Officer for all rehabilitation and demolition of historic properties that are fifty (50) years old or older or that are included on a Federal, state, or local historic property list.

**A. APPLICABILITY**

The Project or Program to which the construction work covered by this Contract pertains is being assisted by the United States of America, and the following Federal Labor Standards Provisions are included in this Contract pursuant to the provisions applicable to such Federal assistance.

**(1) MINIMUM WAGES**

- (i) All laborers and mechanics employed or working upon the site of the work will be paid unconditionally and not less often than once a week, and without subsequent deduction or rebate on any account (except such payroll deductions as are permitted by regulations issued by the Secretary of Labor under the Copeland Act (29 CFR Part 3)), the full amount of wages and bona fide fringe benefits (or cash equivalents thereof) due at time of payment, computed at rates not less than those contained in the wage determination of the Secretary of Labor (which is attached hereto and made a part hereof), regardless of any contractual relationship which may be alleged to exist between the contractor and such laborers and mechanics. Contributions made or costs reasonably anticipated for bona fide fringe benefits under Section 1(b)(2) of the Davis-Bacon Act on behalf of laborers or mechanics are considered wages paid to such laborers or mechanics, subject to the provisions of 29 CFR 5.5(a)(1)(iv); also, regular contributions made or costs incurred for more than a weekly period (but not less often than quarterly) under plans, funds, or programs, which cover the particular weekly period, are deemed to be constructively made or incurred during such weekly period.

Such laborers and mechanics shall be paid the appropriate wage rate and fringe benefits on the wage determination for the classification of work actually performed, without regard to skill, except as provided in 29 CFR 5.5(a)(4). Laborers or mechanics performing work in more than one classification may be compensated at the rate specified for each classification for the time actually worked therein: Provided, that the employer's payroll records accurately set forth the time spent in each classification in which work is performed. The wage determination (including any additional classification and wage rates conformed under 29 CFR 5.5(a)(1)(ii) and the Davis-Bacon poster (WH1321)) shall be posted at all times by the contractor and its subcontractors at the site of the work in a prominent and accessible place, where it can be easily seen by the workers.

**(ii) Additional Classifications.**

- (A) Any class of laborers or mechanics which is not listed in the wage determination and which is to be employed under the contract shall be classified in conformance with the wage determination. HUD shall approve an additional classification and wage rate and fringe benefits therefor only when the following criteria have been met:
- (1) The work to be performed by the classification requested is not performed by a classification in the wage determination;
  - (2) The classification is utilized in the area by the construction industry; and
  - (3) The proposed wage rate, including any bona fide fringe benefits, bears a reasonable relationship to the wage rates contained in the wage determination.
- (B) If the contractor, the laborers and mechanics to be employed in the classification (if known), or their representatives, and HUD or its designee agree on the proposed classification and wage rate (including the amount designated for fringe benefits, where appropriate), a report of the action taken shall be sent by HUD or its designee to the Administrator of the Wage and Hour Division ("Administrator"), Employment Standards Administration, U.S. Department of Labor, Washington, D.C. 20210. The Administrator, or an authorized representative, will approve, modify, or disapprove every additional classification action within 30 days of receipt and so advise HUD or its designee or will notify HUD or its designee within the 30-day period that additional time is necessary. (Approved by the Office of Management and Budget ("OMB") under OMB control number 1235-0023.)
- (C) In the event the contractor, the laborers or mechanics to be employed in the classification or their representatives, or HUD or its designee do not agree on the proposed classification and wage rate (including the amount designated for fringe benefits, where appropriate), HUD or its designee shall refer the questions, including the views of all interested parties and the recommendation of HUD or its designee, to the Administrator for determination. The Administrator, or an authorized representative, will issue a determination within 30 days of receipt and so advise HUD or its designee or will notify HUD or its designee within the 30-day period that additional time is necessary. (Approved by the Office of Management and Budget under OMB Control Number 1235-0023.)

(D) The wage rate (including fringe benefits, where appropriate) determined pursuant to subparagraphs (1)(ii)(B) or (C) of this paragraph, shall be paid to all workers performing work in the classification under this Contract from the first day on which work is performed in the classification.

(iii) Whenever the minimum wage rate prescribed in the contract for a class of laborers or mechanics includes a fringe benefit which is not expressed as an hourly rate, the contractor shall either pay the benefit as stated in the wage determination or shall pay another bona fide fringe benefit or an hourly cash equivalent thereof.

(iv) If the contractor does not make payments to a trustee or other third person, the contractor may consider as part of the wages of any laborer or mechanic the amount of any costs reasonably anticipated in providing bona fide fringe benefits under a plan or program, Provided, that the Secretary of Labor has found, upon the written request of the contractor, that the applicable standards of the Davis-Bacon Act have been met. The Secretary of Labor may require the contractor to set aside in a separate account assets for the meeting of obligations under the plan or program. (Approved by the Office of Management and Budget under OMB Control Number 1235-0023.)

(2) **Withholding.** HUD or its designee shall, upon its own action or upon written request of an authorized representative of the U.S. Department of Labor, withhold or cause to be withheld from the contractor under this contract or any other Federal contract with the same prime contractor, or any other Federally-assisted contract subject to Davis-Bacon prevailing wage requirements which is held by the same prime contractor, so much of the accrued payments or advances as may be considered necessary to pay laborers and mechanics, including apprentices, trainees and helpers, employed by the contractor or any subcontractor the full amount of wages required by the contract. In the event of failure to pay any laborer or mechanic, including any apprentice, trainee or helper, employed or working on the site of the work, all or part of the wages required by the contract, HUD or its designee may, after written notice to the contractor, sponsor, applicant, or owner, take such action as may be necessary to cause the suspension of any further payment, advance, or guarantee of funds until such violations have ceased. HUD or its designee may, after written notice to the contractor, disburse such amounts withheld for and on account of the contractor or subcontractor to the respective employees to whom they are due. The Department of Labor shall make such disbursements in the case of direct Davis-Bacon Act contracts.

(3) **Payrolls and basic records.**

(i) **Maintaining Payroll Records.** Payrolls and basic records relating thereto shall be maintained by the contractor during the course of the work and preserved for a period of three years thereafter for all laborers and mechanics working at the site of the work. Such records shall contain the name, address, and social security number of each such worker, his or her correct classification(s), hourly rates of wages paid (including rates of contributions or costs anticipated for bona fide fringe benefits or cash equivalents thereof of the types described in Section 1(b)(2)(B) of the Davis-Bacon Act), daily and weekly number of hours worked, deductions made, and actual wages paid.

Whenever the Secretary of Labor has found, under 29 CFR 5.5(a)(1)(iv), that the wages of any laborer or mechanic include the amount of any costs reasonably anticipated in providing benefits under a plan or program described in Section 1(b)(2)(B) of the Davis-Bacon Act, the contractor shall maintain records which show that the commitment to provide such benefits is enforceable, that the plan or program is financially responsible, and that the plan or program has been communicated in writing to the laborers or mechanics affected, and records which show the costs anticipated or the actual cost incurred in providing such benefits.

Contractors employing apprentices or trainees under approved programs shall maintain written evidence of the registration of apprenticeship programs and certification of trainee programs, the registration of the apprentices and trainees, and the ratios and wage rates prescribed in the applicable programs. (Approved by the Office of Management and Budget under OMB Control Numbers 1235-0023 and 1215-0018)

(ii) **Certified Payroll Reports.**

(A) The contractor shall submit weekly, for each week in which any contract work is performed, a copy of all payrolls to HUD or its designee if the agency is a party to the contract, but if the agency is not such a party, the contractor will submit the payrolls to the applicant sponsor, or owner, as the case may be, for transmission to HUD or its designee. The payrolls submitted shall set out accurately and completely all of the information required to be maintained under 29 CFR 5.5(a)(3)(i), except that full social security numbers and home addresses shall not be included on weekly transmittals. Instead, the payrolls only need to include an individually identifying number for each employee (e.g., the last four digits of the employee's social security number). The required weekly payroll information may be submitted in any form desired. Optional Form WH-347 is available for this purpose from the Wage and Hour Division Web site at <https://www.dol.gov/agencies/whd/forms> or its successor site. The prime contractor is responsible for the submission of copies of payrolls by all subcontractors.

Contractors and subcontractors shall maintain the full social security number and current address of each covered worker, and shall provide them upon request to HUD or its designee if the agency is a party to the contract, but if the agency is not such a party, the contractor will submit the payrolls to the applicant sponsor, or owner, as the case may be, for transmission to HUD or its designee, the contractor, or the Wage and Hour Division of the U.S. Department of Labor for purposes of an investigation or audit of compliance with prevailing wage requirements. It is not a violation of this subparagraph for a prime contractor to require a subcontractor to provide addresses and social security numbers to the prime contractor for its own records, without weekly submission to HUD or its designee. (Approved by the Office of Management and Budget under OMB Control Number 1235-0008.)

- (B)** Each payroll submitted shall be accompanied by a “Statement of Compliance,” signed by the contractor or subcontractor or his or her agent who pays or supervises the payment of the persons employed under the contract and shall certify the following:
- (1)** That the payroll for the payroll period contains the information required to be provided under 29 CFR 5.5(a)(3)(ii), the appropriate information is being maintained under 29 CFR 5.5(a)(3)(i), and that such information is correct and complete;
  - (2)** That each laborer or mechanic (including each helper, apprentice, and trainee) employed on the contract during the payroll period has been paid the full weekly wages earned, without rebate, either directly or indirectly, and that no deductions have been made either directly or indirectly from the full wages earned, other than permissible deductions as set forth in 29 CFR Part 3;
  - (3)** That each laborer or mechanic has been paid not less than the applicable wage rates and fringe benefits or cash equivalents for the classification of work performed, as specified in the applicable wage determination incorporated into the contract; and
- (C)** The weekly submission of a properly executed certification set forth on the reverse side of Optional Form WH-347 shall satisfy the requirement for submission of the “Statement of Compliance” required by subparagraph (a)(3)(ii)(b).
- (D)** The falsification of any of the above certifications may subject the contractor or subcontractor to civil or criminal prosecution under Section 1001 of Title 18 and Section 3729 of Title 31 of the United States Code.

**(iii)** The contractor or subcontractor shall make the records required under subparagraph (a)(3)(i) available for inspection, copying, or transcription by authorized representatives of HUD or its designee or the U.S. Department of Labor, and shall permit such representatives to interview employees during working hours on the job. If the contractor or subcontractor fails to submit the required records or to make them available, HUD or its designee may, after written notice to the contractor, sponsor, applicant, or owner, take such action as may be necessary to cause the suspension of any further payment, advance, or guarantee of funds. Furthermore, failure to submit the required records upon request or to make such records available may be grounds for debarment action pursuant to 29 CFR 5.12.

#### **(4) Apprentices and Trainees.**

**(i) Apprentices.** Apprentices will be permitted to work at less than the predetermined rate for the work they performed when they are employed pursuant to and individually registered in a bona fide apprenticeship program registered with the U.S. Department of Labor, Employment and Training Administration, Office of Apprenticeship Training, Employer and Labor Services, or with a State Apprenticeship Agency recognized by the Office, or if a person is employed in his or her first 90 days of probationary employment as an apprentice in such an apprenticeship program, who is not individually registered in the program, but who has been certified by the Office of Apprenticeship Training, Employer and Labor Services, or a State Apprenticeship Agency (where appropriate), to be eligible for probationary employment as an apprentice.

The allowable ratio of apprentices to journeymen on the job site in any craft classification shall not be greater than the ratio permitted to the contractor as to the entire work force under the registered program. Any worker listed on a payroll at an apprentice wage rate, who is not registered or otherwise employed as stated above, shall be paid not less than the applicable wage rate on the wage determination for the classification of work actually performed. In addition, any apprentice performing work on the job site in excess of the ratio permitted under the registered program shall be paid not less than the applicable wage rate on the wage determination for the work actually performed. Where a contractor is performing construction on a project in a locality other than that in which its program is registered, the ratios and wage rates (expressed in percentages of the journeyman’s hourly rate) specified in the contractor’s or subcontractor’s registered program shall be observed.

Every apprentice must be paid at not less than the rate specified in the registered program for the apprentice’s level of progress, expressed as a percentage of the journeymen hourly rate specified in the applicable wage determination.

Apprentices shall be paid fringe benefits in accordance with the provisions of the apprenticeship program.

If the apprenticeship program does not specify fringe benefits, apprentices must be paid the full amount of fringe benefits listed on the wage determination for the applicable classification. If the Administrator determines that a different practice prevails for the applicable apprentice classification, fringe benefits shall be paid in accordance with that determination. In the event the Office of Apprenticeship Training, Employer and Labor Services, or a State Apprenticeship Agency recognized by the Office, withdraws approval of an apprenticeship program, the contractor will no longer be permitted to utilize apprentices at less than the applicable predetermined rate for the work performed until an acceptable program is approved.

- (ii) **Trainees.** Except as provided in 29 CFR 5.16, trainees will not be permitted to work at less than the predetermined rate for the work performed, unless they are employed pursuant to and individually registered in a program which has received prior approval, evidenced by formal certification by the U.S. Department of Labor, Employment and Training Administration. The ratio of trainees to journeymen on the job site shall not be greater than permitted under the plan approved by the Employment and Training Administration. Every trainee must be paid at not less than the rate specified in the approved program for the trainee's level of progress, expressed as a percentage of the journeyman hourly rate specified in the applicable wage determination. Trainees shall be paid fringe benefits in accordance with the provisions of the trainee program. If the trainee program does not mention fringe benefits, trainees shall be paid the full amount of fringe benefits listed on the wage determination unless the Administrator of the Wage and Hour Division determines that there is an apprenticeship program associated with the corresponding journeyman wage rate on the wage determination which provides for less than full fringe benefits for apprentices. Any employee listed on the payroll at a trainee rate who is not registered and participating in a training plan approved by the Employment and Training Administration shall be paid not less than the applicable wage rate on the wage determination for the work actually performed.

In addition, any trainee performing work on the job site in excess of the ratio permitted under the registered program shall be paid not less than the applicable wage rate on the wage determination for the work actually performed. In the event the Employment and Training Administration withdraws approval of a training program, the contractor will no longer be permitted to utilize trainees at less than the applicable predetermined rate for the work performed until an acceptable program is approved.

- (iii) **Equal employment opportunity.** The utilization of apprentices, trainees, and journeymen under 29 CFR Part 5 shall be in conformity with the equal employment opportunity requirements of Executive Order 11246, as amended, and 29 CFR Part 30.

- (5) **Compliance with Copeland Act requirements.** The contractor shall comply with the requirements of 29 CFR Part 3, which are incorporated by reference in this Contract.
- (6) **Subcontracts.** The contractor or subcontractor will insert in any subcontracts the clauses contained in subparagraphs (1) through (11) in this paragraph (a) and such other clauses as HUD or its designee may, by appropriate instructions, require, and a copy of the applicable prevailing wage decision, and also a clause requiring the subcontractors to include these clauses in any lower tier subcontracts. The prime contractor shall be responsible for the compliance by any subcontractor or lower tier subcontractor with all the contract clauses in this paragraph.
- (7) **Contract termination; debarment.** A breach of the contract clauses in 29 CFR 5.5 may be grounds for termination of the contract and for debarment as a contractor and a subcontractor as provided in 29 CFR 5.12.
- (8) **Compliance with Davis-Bacon and Related Act Requirements.** All rulings and interpretations of the Davis-Bacon and Related Acts contained in 29 CFR Parts 1, 3, and 5 are herein incorporated by reference in this Contract.
- (9) **Disputes concerning labor standards.** Disputes arising out of the labor standards provisions of this Contract shall not be subject to the general disputes clause of this Contract. Such disputes shall be resolved in accordance with the procedures of the U.S. Department of Labor set forth in 29 CFR Parts 5, 6, and 7. Disputes within the meaning of this clause include disputes between the contractor (or any of its subcontractors) and HUD or its designee, the U.S. Department of Labor, or the employees or their representatives.
- (10) **Certification of Eligibility.**
- (i) By entering into this Contract, the contractor certifies that neither it (nor he or she) nor any person or firm who has an interest in the contractor's firm is a person or firm ineligible to be awarded Government contracts by virtue of Section 3(a) of the Davis-Bacon Act or 29 CFR 5.12(a)(1) or to be awarded HUD contracts or participate in HUD programs pursuant to 24 CFR Part 24.

(ii) No part of this Contract shall be subcontracted to any person or firm ineligible for award of a Government contract by virtue of Section 3(a) of the Davis-Bacon Act or 29 CFR 5.12(a)(1) or to be awarded HUD contracts or participate in HUD programs pursuant to 24 CFR Part 24.

(iii) Anyone who knowingly makes, presents, or submits a false, fictitious, or fraudulent statement, representation or certification is subject to criminal, civil and/or administrative sanctions, including fines, penalties, and imprisonment (e.g., 18 U.S.C. §§ 287, 1001, 1010, 1012; 31 U.S.C. §§ 3729, 3802).

**(11) Complaints, Proceedings, or Testimony by Employees.** No laborer or mechanic, to whom the wage, salary, or other labor standards provisions of this Contract are applicable, shall be discharged or in any other manner discriminated against by the contractor or any subcontractor because such employee has filed any complaint or instituted or caused to be instituted any proceeding or has testified or is about to testify in any proceeding under or relating to the labor standards applicable under this Contract to his employer.

## **B. CONTRACT WORK HOURS AND SAFETY STANDARDS ACT**

The provisions of this paragraph (b) are applicable where the amount of the prime contract exceeds **\$100,000**. As used in this paragraph, the terms “laborers” and “mechanics” include watchmen and guards.

**(1) Overtime requirements.** No contractor or subcontractor contracting for any part of the contract work, which may require or involve the employment of laborers or mechanics, shall require or permit any such laborer or mechanic in any workweek in which the individual is employed on such work to work in excess of 40 hours in such workweek, unless such laborer or mechanic receives compensation at a rate not less than one and one-half times the basic rate of pay for all hours worked in excess of 40 hours in such workweek.

**(2) Violation; liability for unpaid wages; liquidated damages.** In the event of any violation of the clause set forth in subparagraph B(1) of this paragraph, the contractor, and any subcontractor responsible therefor, shall be liable for the unpaid wages. In addition, such contractor and subcontractor shall be liable to the United States (in the case of work done under contract for the District of Columbia or a territory, to such District or to such territory) for liquidated damages. Such liquidated damages shall be computed with respect to each individual laborer or mechanic, including watchmen and guards, employed in violation of the clause set forth in subparagraph B(1) of this paragraph, in the sum of **\$27** for each calendar day on which such individual was required or permitted to work in excess of the standard workweek of 40 hours without payment of the overtime wages required by the clause set forth in subparagraph B(1) of this paragraph. In accordance with the Federal Civil Penalties Inflation Adjustment Act of 1990 (28 U.S.C. § 2461 Note), the Department of Labor adjusts this civil monetary penalty for inflation no later than January 15 each year.

**(3) Withholding for unpaid wages and liquidated damages.** HUD or its designee shall, upon its own action or upon written request of an authorized representative of the U.S. Department of Labor, withhold or cause to be withheld from any moneys payable on account of work performed by the contractor or subcontractor under any such contract, or any other Federal contract with the same prime contract, or any other Federally-assisted contract subject to the Contract Work Hours and Safety Standards Act which is held by the same prime contractor, such sums as may be determined to be necessary to satisfy any liabilities of such contractor or subcontractor for unpaid wages and liquidated damages, as provided in the clause set forth in subparagraph B(2) of this paragraph.

**(4) Subcontracts.** The contractor or subcontractor shall insert in any subcontracts the clauses set forth in subparagraph B(1) through (4) of this paragraph and also a clause requiring the subcontractors to include these clauses in any lower tier subcontracts. The prime contractor shall be responsible for compliance by any subcontractor or lower tier subcontractor with the clauses set forth in subparagraphs B(1) through (4) of this paragraph.

## **C. HEALTH AND SAFETY**

The provisions of this paragraph (c) are applicable where the amount of the prime contract exceeds **\$100,000**.

**(1)** No laborer or mechanic shall be required to work in surroundings or under working conditions which are unsanitary, hazardous, or dangerous to his or her health and safety, as determined under construction safety and health standards promulgated by the Secretary of Labor by regulation.

**(2)** The contractor shall comply with all regulations issued by the Secretary of Labor pursuant to 29 CFR Part 1926 and failure to comply may result in imposition of sanctions pursuant to the Contract Work Hours and Safety Standards Act, (Public Law 91-54, 83 Stat 96), 40 U.S.C. § 3701 et seq.

**(3)** The contractor shall include the provisions of this paragraph in every subcontract, so that such provisions will be binding on each subcontractor. The contractor shall take such action with respect to any subcontractor as the Secretary of Housing and Urban Development or the Secretary of Labor shall direct as a means of enforcing such provisions.

# Contract Work Hours and, Safety Standards Act, as Amended

---



U.S. Department of Labor  
Employment Standards Administration  
Wage and Hour Division

WH Publication 1432  
(Revised April 2009)

Materials contained in this publication is in the public domain and may be reproduced, fully or partially, without permission of the federal Government. Source credit is requested but not required. Permission is required only to reproduce any copyrighted material contained herein.

This material will be made available to Sensory impaired individuals upon request. Voice phone: 202-693-0675 TDD\* phone: 202-523-9530

PUBLIC LAW 107–217—AUG. 21, 2002 [as amended<sup>1</sup>]

## An Act

To revise, codify, and enact without substantive change certain general and permanent laws, related to public buildings, property, and works, as title 40, United States Code, “Public Buildings, Property, and Works”.

*Be it enacted by the Senate and House of Representatives of the United States of America in Congress assembled,*

### SECTION 1. TITLE 40, UNITED STATES CODE.

Certain general and permanent laws of the United States, related to public buildings, property, and works, are revised, codified, and enacted as title 40, United States Code, “Public Buildings, Property, and Works”, as follows:

#### TITLE 40—PUBLIC BUILDINGS, PROPERTY, AND WORKS

\* \* \* \*

#### SUBTITLE II—PUBLIC BUILDINGS AND WORKS

#### PART A—GENERAL

\* \* \* \*

#### CHAPTER 37 – CONTRACT WORK HOURS AND SAFETY STANDARDS

\* \* \* \*

#### Sec. 3141. Definitions

(a) Definition.— In this chapter, the term “Federal Government” has the same meaning that the term “United States” had in the Contract Work Hours and Safety Standards Act (Public Law 87–581, 76 Stat. 357).

(b) Application.—

(1) Contracts.— This chapter applies to—

<sup>1</sup>Pub. L. 109-284 Sec. 6(14), (15), (16), and (17) made minor technical corrections in Secs 3701, 3702, and 3704 (Sept. 27, 2006, 120 Stat. 1213.)

<sup>2</sup>The Contract Work Hours and Safety Standards Act, referred to in subsec. (a), is title I of Pub. L. 87–581, Aug. 13, 1962, 76 Stat. 357, as amended, which was classified generally to subchapter II (Sec. 327 et seq.) of chapter 5 of former Title 40, Public Buildings, Property, and Works, prior to repeal and reenactment as this chapter by Pub. L. 107–217, Secs. 1, 6 (b), Aug. 21, 2002, 116 Stat. 1062, 1304. Section 101 of title I of Pub. L. 87–581 was classified to section 327 of former Title 40 and was repealed and not reenacted by Pub. L. 107–217.



(A) any contract that may require or involve the employment of laborers or mechanics on a public work of the Federal Government, a territory of the United States,

or the District of Columbia; and

(B) any other contract that may require or involve the employment of laborers or mechanics if the contract is one—

(i) to which the Government, an agency or instrumentality of the Government, a territory, or the District of Columbia is a party;

(ii) which is made for or on behalf of the Government, an agency or instrumentality, a territory, or the District of Columbia; or

(iii) which is a contract for work financed at least in part by loans or grants from, or loans insured or guaranteed by, the Government or an agency or instrumentality under any federal law providing wage standards for the work.

(2) Laborers and mechanics.— This chapter applies to all laborers and mechanics employed by a contractor or subcontractor in the performance of any part of the work under the contract—

(A) including watchmen, guards, and workers performing services in connection with dredging or rock excavation in any river or harbor of the United States, a territory,

or the District of Columbia; but

(B) not including an employee employed as a seaman.

(3) Exceptions.—

(A) This chapter.— This chapter does not apply to—

(i) a contract for—

(I) transportation by land, air, or water;

(II) the transmission of intelligence; or

(III) the purchase of supplies or materials or articles ordinarily available in the open market;

(ii) any work required to be done in accordance with the provisions of the Walsh-Healey Act (41 U.S.C. 35 et seq.); and

(iii) a contract in an amount that is not greater than \$100,000.

(B) Section 3702.— Section 3702 of this title does not apply to work where the assistance described in paragraph (1)(B)(iii) from the Government or an agency or instrumentality is only a loan guarantee or insurance.

### **3702. Work hours.**

(a) Standard Workweek.— The wages of every laborer and mechanic employed by any contractor or subcontractor in the performance of work on a contract described in section 3701 of this title shall be computed on the basis of a standard workweek of 40 hours. Work in excess of the standard workweek is permitted subject to this section. For each workweek in which the laborer or mechanic is so employed, wages include compensation, at a rate not less than one and one-half times the basic rate of pay, for all hours worked in excess of 40 hours in the workweek.

(b) Contract Requirements.— A contract described in section 3701 of this title, and any obligation of the Federal Government, a territory of the United States, or the District of Columbia in connection with that contract, must provide that—

(1) a contractor or subcontractor contracting for any part of the contract work which may require or involve the employment of laborers or mechanics shall not require or permit any laborer or mechanic, in any workweek in which the laborer or mechanic is employed on that work, to work more than 40 hours in that workweek, except as provided in this chapter; and

(2) when a violation of clause (1) occurs, the contractor and any subcontractor responsible for the violation are liable—

(A) to the affected employee for the employee's unpaid wages; and

(B) to the Government, the District of Columbia, or a territory for liquidated damages as provided in the contract.

(c) Liquidated Damages.— Liquidated damages under subsection (b)(2)(B) shall be computed for each individual employed as a laborer or mechanic in violation of this chapter and shall be equal to \$10 for each calendar day on which the individual was required or permitted to work in excess of the standard workweek without payment of the overtime wages required by this chapter.

(d) Amounts Withheld to Satisfy Liabilities.— Subject to section 3703 of this title, the governmental agency for which the contract work is done or which is providing financial assistance for the work may withhold, or have withheld, from money payable because of work performed by a contractor or subcontractor, amounts administratively determined to be necessary to satisfy the liabilities of the contractor or subcontractor for unpaid wages and liquidated damages as provided in this section.

### **3703. Report of violations and withholding of amounts for unpaid wages and liquidated damages.**

(a) Reports of Inspectors.— An officer or individual designated as an inspector of the work to be performed under a contract described in section 3701 of this title, or to aid in the enforcement or fulfillment of the contract, on observation or after investigation immediately shall report to the proper officer of the Federal Government, a territory of the United States, or the District of Columbia all violations of this chapter occurring in the performance of the work, together with the name of each laborer or mechanic who was required or permitted to work in violation of this chapter and the day the violation occurred.

(b) Withholding Amounts.—

(1) Determining amount.— The amount of unpaid wages and liquidated damages owing under this chapter shall be determined administratively.

(2) Amount directed to be withheld.— The officer or individual whose duty it is to approve the payment of money by the Government, territory, or District of Columbia in connection with the performance of the contract work shall direct the amount of—

(A) liquidated damages to be withheld for the use and benefit of the Government, territory, or District; and

(B) unpaid wages to be withheld for the use and benefit of the laborers and mechanics who were not compensated as required under this chapter.

(3) Payment.— The Comptroller General shall pay the amount administratively determined to be due directly to the laborers and mechanics from amounts withheld on account of underpayments of wages if the amount withheld is adequate. If the amount withheld is not adequate, the Comptroller General shall pay an equitable proportion of the amount due.

(c) Right of Action and Intervention Against Contractors and Sureties.— If the accrued payments withheld under the terms of the contract are insufficient to reimburse all the laborers and mechanics who have not been paid the wages required under this chapter, the laborers and mechanics, in the case of a department or agency of the Government, have the same right of action and intervention against the contractor and the contractor's sureties as is conferred by law on persons furnishing labor or materials. In those proceedings it is not a defense that the laborers and mechanics accepted or agreed to accept less than the required rate of wages or voluntarily made refunds.

(d) Review Process.—

(1) Time limit for appeal.— Within 60 days after an amount is withheld as liquidated damages, any contractor or subcontractor aggrieved by the withholding may appeal to the head of the agency of the Government or territory for which the contract work is done or which is providing financial assistance for the work, or to the Mayor of the District of Columbia in the case of liquidated damages withheld for the use and benefit of the District.

(2) Review by agency head or mayor.— The agency head or Mayor may review the administrative determination of liquidated damages. The agency head or Mayor may issue a final order affirming the determination or may recommend to the Secretary of Labor that an appropriate adjustment in liquidated damages be made, or that the contractor or subcontractor be relieved of liability for the liquidated damages, if it is found that the amount is incorrect or that the contractor or subcontractor violated this chapter inadvertently, notwithstanding the exercise of due care by the contractor or subcontractor and the agents of the contractor or subcontractor.

(3) Review by secretary.— The Secretary shall review all pertinent facts in the matter and may conduct any investigation the Secretary considers necessary in order to affirm or reject the recommendation. The decision of the Secretary is final.

(4) Judicial action.— A contractor or subcontractor aggrieved by a final order for the withholding of liquidated damages may file a claim in the United States Court of Federal Claims within 60 days after the final order. A final order of the agency head, Mayor, or Secretary is conclusive with respect to findings of fact if supported by substantial evidence.

(e) Applicability of Other Laws.—

(1) Reorganization plan.— Reorganization Plan Numbered 14 of 1950 (eff. May 24, 1950, 64 Stat. 1267) applies to this chapter.

(2) Section 3145.— Section 3145 of this title applies to contractors and subcontractors referred to in section 3145 who are engaged in the performance of contracts subject to this chapter.

### **3704. Health and safety standards in building trades and construction industry.**

(a) Condition of Contracts.—

(1) In general.— Each contract in an amount greater than \$100,000 that is entered into under legislation subject to Reorganization Plan Numbered 14 of 1950 (eff. May 24, 1950, 64 Stat. 1267) and is for construction, alteration, and repair, including painting and decorating, must provide that no contractor or subcontractor contracting for any part of the contract work shall require any laborer or mechanic employed in the performance of the contract to work in surroundings or under working conditions that are unsanitary, hazardous, or dangerous to health or safety, as established under construction safety and health standards the Secretary of Labor prescribes by regulation based on proceedings pursuant to section 553 of title 5, provided that the proceedings include a hearing similar in nature to that authorized by section 553 of title 5.

(2) Consultation.— In formulating standards under this section, the Secretary shall consult with the Advisory Committee created by subsection (d).

(b) Compliance.—

(1) Actions to gain compliance.— The Secretary may make inspections, hold hearings, issue orders, and make decisions based on findings of fact as the Secretary considers necessary to gain compliance with this section and any health and safety standard the Secretary prescribes under subsection (a). For those purposes the Secretary and the United States district courts have the authority and jurisdiction provided by sections 4 and 5 of the Walsh-Healey Act (41 U.S.C. 38, 39).

(2) Remedy when noncompliance found.— When the Secretary, after an opportunity for an adjudicatory hearing by the Secretary, establishes noncompliance under this section of any condition of a contract described in—

(A) section 3701 (b)(1)(B)(i) or (ii) of this title, the governmental agency for which the contract work is done may cancel the contract and make other contracts for the completion of the contract work, charging any additional cost to the original contractor; or

(B) section 3701 (b)(1)(B)(iii) of this title, the governmental agency which is providing the financial guarantee, assistance, or insurance for the contract work may withhold the guarantee, assistance, or insurance attributable to the performance of the contract.

(3) Nonapplicability.— Section 3703 of this title does not apply to the enforcement of this section.

(c) Repeated Violations.—

(1) Transmittal of names of repeat violators to comptroller general.— When the Secretary, after an opportunity for an agency hearing, decides on the record that, by repeated willful or grossly negligent violations of this chapter, a contractor or subcontractor has demonstrated that subsection (b) is not effective to protect the safety and health of the employees of the contractor or subcontractor, the Secretary shall make a finding to that effect and, not sooner than 30 days after giving notice of the finding to all interested persons, shall transmit the name of the contractor or subcontractor to the Comptroller General.

(2) Ban on awarding contracts.— The Comptroller General shall distribute each name transmitted under paragraph (1) to all agencies of the Federal Government. Unless the Secretary otherwise recommends, the contractor, subcontractor, or any person in which the contractor or subcontractor has a substantial interest may not be awarded a contract subject to this section until three years have elapsed from the date the name is transmitted to the Comptroller General. The Secretary shall terminate the ban if, before the end of the three-year period, the Secretary, after affording interested persons due notice and an opportunity for a hearing, is satisfied that a contractor or subcontractor whose name was transmitted to the Comptroller General will comply responsibly with the requirements of this section. The Comptroller General shall inform all Government agencies after being informed of the Secretary's action.

(3) Judicial review.— A person aggrieved by the Secretary's action under this subsection or subsection (b) may file with the appropriate United States court of appeals a petition for review of the Secretary's action within 60 days after receiving notice of the Secretary's action. The clerk of the court immediately shall send a copy of the petition to the Secretary. The Secretary then shall file with the court the record on which the action is based. The findings of fact by the Secretary, if supported by substantial evidence, are final. The court may enter a decree enforcing, modifying, modifying and enforcing, or setting aside any part of, the order of the Secretary or the appropriate Government agency. The judgment of the court may be reviewed by the Supreme Court as provided in section 1254 of title 28.

(d) Advisory Committee on Construction Safety and Health.—

(1) Establishment.— There is an Advisory Committee on Construction Safety and Health in the Department of Labor.

(2) Composition.— The Committee is composed of nine members appointed by the Secretary, without regard to chapter 33 of title 5, as follows:

(A) Three members shall be individuals representative of contractors to whom this section applies.

(B) Three members shall be individuals representative of employees primarily in the building trades and construction industry engaged in carrying out contracts to which this section applies.

(C) Three members shall be public representatives who shall be selected on the basis of their professional and technical competence and experience in the construction health and safety field.

(3) Chairman.— The Secretary shall appoint one member as Chairman.

(4) Duties.— The Committee shall advise the Secretary—

(A) in formulating construction safety and health standards and other regulations; and

(B) on policy matters arising in carrying out this section.

(5) Experts and Consultants.— The Secretary may appoint special advisory and technical experts or consultants as may be necessary to carry out the functions of the Committee.

(6) Compensation and expenses.— Committee members are entitled to receive compensation at rates the Secretary fixes, but not more than \$100 a day, including traveltime, when performing Committee business, and expenses under section 5703 of title 5.

### **3705. Safety programs.**

The Secretary of Labor shall—

(1) provide for the establishment and supervision of programs for the education and training of employers and employees in the recognition, avoidance, and prevention of unsafe working conditions in employment covered by this chapter; and

(2) collect reports and data and consult with and advise employers as to the best means of preventing injuries.

### **3706. Limitations, variations, tolerances, and exemptions.**

The Secretary of Labor may provide reasonable limitations to, and may prescribe regulations allowing reasonable variations to, tolerances from, and exemptions from, this chapter that the Secretary may find necessary and proper in the public interest to prevent injustice or undue hardship or to avoid serious impairment of the conduct of Federal Government business.

### **3707. Contractor certification or contract clause in acquisition of commercial items not required.**

In a contract to acquire a commercial item (as defined in section 4 of the Office of Federal Procurement Policy Act (41 U.S.C. 403)), a certification by a contractor or a contract clause may not be required to implement a prohibition or requirement in this chapter.

### **3708. Criminal penalties.**

A contractor or subcontractor having a duty to employ, direct, or control a laborer or mechanic employed in the performance of work contemplated by a contract to which this chapter applies that intentionally violates this chapter shall be fined under title 18, imprisoned for not more than six months, or both.

## **Copeland "Anti-kickback" Act**

### **TITLE 18, U.S.C.**

#### **Sec. 874. Kickbacks from public works employees**

Whoever, by force, intimidation, or threat of procuring dismissal from employment, or by any other manner whatsoever induces any person employed in the construction, prosecution, completion or repair of any public building, public work, or building or work financed in whole or in part by loans or grants from the United States, to give up any part of the compensation to which he is entitled under his contract of employment, shall be fined under this title or imprisoned not more than five years, or both.

[18 U.S.C. 874 (June 25, 1948, ch. 645, Sec. 1, 62 Stat. 740 and 862, eff. Sept. 1, 1948) replaced the former sec. 1 of the Copeland Act of June 13, 1934 (48 Stat. 948). Prior to 1948, Section 1 of the Copeland Act was codified as 40 U.S.C. 276b. P.L. 103-322, (Sept. 13, 1994, 108 Stat. 2147), substituted "fined under this title" for "fined not more than \$5,000".]

### **TITLE 40, U.S.C.**

#### **Sec. 3145. Regulations governing contractors and subcontractors**

(a) In General.—The Secretary of Labor shall prescribe reasonable regulations for contractors and subcontractors engaged in constructing, carrying out, completing, or repairing public buildings, public works, or buildings or works that at least partly are financed by a loan or grant from the Federal Government. The regulations shall include a provision that each contractor and subcontractor each week must furnish a statement on the wages paid each employee during the prior week.

(b) Application.—Section 1001 of title 18 applies to the statements.

[Section 2 of the original Act of June 13, 1934, as amended prior to 2002, and codified as 40 U.S.C. 276c, was repealed, revised and codified as 40 U.S.C. 3145 by P.L. 107-217 (Aug. 21, 2002, 116 Stat. 1152, 1304, 1309, 1313, 1315).]

## CODE OF FEDERAL REGULATIONS

### Title 24 - Housing and Urban Development

Volume: 3 Date: 2010-04-01 Original Date: 2010-04-01

Context: Title 24 - Housing and Urban Development. Subtitle B - Regulations Relating to Housing and Urban Development

CHAPTER V - OFFICE OF ASSISTANT SECRETARY FOR COMMUNITY PLANNING AND DEVELOPMENT, DEPARTMENT OF HOUSING AND URBAN DEVELOPMENT.  
SUBCHAPTER C - COMMUNITY FACILITIES.

PART 570 - COMMUNITY DEVELOPMENT BLOCK GRANTS. Subpart K - Other Program Requirements.

#### **§ 570.603 Labor standards** ([eCFR :: 24 CFR 570.603 -- Labor standards.](#))

(a) Section 110(a) of the Act contains labor standards that apply to nonvolunteer labor financed in whole or in part with assistance received under the Act. In accordance with section 110(a) of the Act, the Contract Work Hours and Safety Standards Act (40 U.S.C. 327 *et seq.*) also applies. However, these requirements apply to the rehabilitation of residential property only if such property contains not less than 8 units. (b) The regulations in 24 CFR part 70 apply to the use of volunteers.

[61 FR 11477, Mar. 20, 1996]

#### **§ 570.609 Use of debarred, suspended or ineligible contractors or subrecipients** ([eCFR :: 24 CFR 570.609 -- Use of debarred, suspended or ineligible contractors or subrecipients.](#))

The requirements set forth in 24 CFR part 5 apply to this program.

[61 FR 5209, Feb. 9, 1996]

**REQUIREMENT FOR AFFIRMATIVE ACTION TO ENSURE  
EQUAL EMPLOYMENT OPPORTUNITY (EXECUTIVE ORDER 11246)**

The Executive Order 11246 (E.O 11246), found at: [Executive Order 11246 – Equal Employment Opportunity | U.S. Department of Labor \(dol.gov\)](#), prohibits federal contractors and subcontractors and federally-assisted construction contractors and subcontractors that generally have contracts that exceed \$10,000 from discriminating in employment decisions on the basis of race, color, religion, sex, or national origin. It also requires covered contractors to take affirmative action to ensure that equal opportunity is provided in all aspects of their employment.

The E.O. 11246 is administered by the Office of Federal Contract Compliance Programs (OFCCP) within the U.S. Department of Labor. The OFCCP regulations implementing the E.O. 11246 can be found at 41 CFR Parts 60-1 through 60-50 at:

[eCFR :: 41 CFR Chapter 60 -- Office of Federal Contract Compliance Programs, Equal Employment Opportunity, Department of Labor](#)

Construction compliance FAQs: [Construction Compliance Frequently Asked Questions | U.S. Department of Labor \(dol.gov\)](#)

1. The Offeror's or Bidder's attention is called to the “Equal Opportunity Clause” and the “Standard Federal Equal Employment Specifications” set forth herein.
2. The OFCCP establishes goals and specifies affirmative action which must be undertaken by Federal and federally assisted construction contractors per Appendix P: Participation Goals for Minorities and Females ([U. S. Department of Labor; Office of Federal Contract Compliance Programs Construction Contractors Technical Assistance Guide \(dol.gov\)](#)). The goals and timetables for minority and female participation, expressed in percentage terms for the Contractor's aggregate workforce in each trade on all construction work in the covered area, are as follows per Appendix P:

Timetables	Goals for minority participation in each trade	Goals for female participation in each trade
	24.6%	6.9%

These goals are applicable to all the Contractor's construction work (whether or not it is Federal or federally assisted) performed in the covered area. If the contractor performs construction work in a geographical area located outside of the covered area, it shall apply the goals established for such geographical area where the work is actually performed. With regard to this second area, the contractor also is subject to the goals for both its federally involved and non-federally involved construction.

**AFFIRMATIVE ACTION REQUIREMENTS**

The Contractor's compliance with the Executive Order and the regulations in 41 CFR Part 60-4 (regulations issued by the Office of Federal Contract Compliance Programs implementing Executive Order 11246) shall be based on its implementation of the Equal Opportunity Clause, specific affirmative action obligations required by the specifications set forth in 41 CFR 60-4.3(a), and its efforts to meet the goals. The hours of minority and female employment and training must be substantially uniform throughout the length of the contract, and in each trade, and the contractor shall make a good faith effort to employ minorities and women evenly on each of its projects. The transfer of minority or female employees or trainees from Contractor to Contractor or from project to project for the sole purpose of meeting the Contractor's goals shall be a violation of the contract, the Executive Order and the regulations in 41 CFR Part 60-4. Compliance with the goals will be measured against the total work hours performed. Further information may be found in the Federal Contract Compliance Manual (FCCM), found at

[Federal Contract Compliance Manual \(FCCM\) \(dol.gov\)](https://www.dol.gov/eoc/fccm/)

3. The Contractor shall provide written notification to the Director of the Office of Federal Contract Compliance Programs within 10 working days of award of any construction subcontract in excess of \$10,000 at any tier for construction work under the contract resulting from this solicitation. The notification shall list the name, address and telephone number of the subcontractor; employer identification number of the subcontractor; estimated dollar amount of the subcontract; estimated starting and completion dates of the subcontract; and the geographical area in which the subcontract is to be performed.

**STANDARD FEDERAL EQUAL EMPLOYMENT OPPORTUNITY  
CONSTRUCTION CONTRACT SPECIFICATIONS (EXECUTIVE ORDER 11246)**

1. As used in these specifications:
  - a. "Covered area" means the geographical area described in the solicitation from which this contract resulted;
  - b. "Director" means Director, Office of Federal Contract Compliance Programs, United States Department of Labor, or any person to whom the Director delegates authority;
  - c. "Employer identification number" means the Federal Social Security number used on the Employer's Quarterly Federal Tax Return, U.S. Treasury Department Form 941.
  - d. "Minority" includes:
    - (i) Black (all persons having origins in any of the Black African racial groups not of Hispanic origin);

AFFIRMATIVE ACTION REQUIREMENTS

Page 2 of 10

- (ii) Hispanic (all persons of Mexican, Puerto Rican, Cuban, Central or South American or other Spanish Culture or origin, regardless of race);
  - (iii) Asian and Pacific Islander (all persons having origins in any of the original peoples of the Far East, Southeast Asia, the Indian Subcontinent, or the Pacific Islands); and
  - (iv) American Indian or Alaskan Native (all persons having origins in any of the original peoples of North America and maintaining identifiable tribal affiliations through membership and participation or community identification).
2. Whenever the Contractor, or any Subcontractor at any tier, subcontracts a portion of the work involving any construction trade, it shall physically include in each subcontract in excess of \$10,000 the provisions of these specifications and the Notice which contains the applicable goals for minority and female participation and which is set forth in the solicitations from which this contract resulted.
  3. If the Contractor is participating (pursuant to 41 CFR 60-4.5) in a Hometown Plan approved by the U.S. Department of Labor in the covered area either individually or through an association, its affirmative action obligations on all work in the Plan area (including goals and timetables) shall be in accordance with that Plan for those trades which have unions participating in the Plan. Contractors must be able to demonstrate their participation in and compliance with the provisions of any such Hometown Plan. Each Contractor or Subcontractor participating in an approved Plan is individually required to comply with its obligations under the EEO clause, and to make a good faith effort to achieve each goal under the Plan in each trade in which it has employees. The overall good faith performance by other Contractors or Subcontractors toward a goal in an approved Plan does not excuse any covered Contractor's or Subcontractor's failure to take good faith efforts to achieve the Plan goals and timetables.
  4. The Contractor shall implement the specific affirmative action standards provided in paragraphs 7 a through p of these specifications. The goals set forth in the solicitation from which this contract resulted are expressed as percentages of the total hours of employment and training of minority and female utilization the Contractor should reasonably be able to achieve in each construction trade in which it has employees in the covered area. Covered Construction contractors performing construction work in geographical areas where they do not have a Federal or federally assisted construction contract shall apply the minority and female goals established for the geographical area where the work is being performed. Goals are published periodically in the Federal Register in notice form, and such notices may be obtained from any Office of Federal Contract Compliance Programs office or from Federal procurement contracting officers. The Contractor is expected to make substantially uniform progress in meeting its goals in each craft during the period specified.
  5. Neither the provisions of any collective bargaining agreement, nor the failure by a union with whom the Contractor has a collective bargaining agreement, to refer either minorities

#### AFFIRMATIVE ACTION REQUIREMENTS



or women shall excuse the Contractor's obligations under these specifications, Executive Order 11246, or the regulations promulgated pursuant thereto.

6. In order for the nonworking training hours of apprentices and trainees to be counted in meeting the goals, such apprentices and trainees must be employed by the Contractor during the training period, and the Contractor must have made a commitment to employ the apprentices and trainees at the completion of their training, subject to the availability of employment opportunities. Trainees must be trained pursuant to training programs approved by the U.S. Department of Labor.
7. The Contractor shall take specific affirmative actions to ensure equal employment opportunity. The evaluation of the Contractor's compliance with these specifications shall be based upon its effort to achieve maximum results from its actions. The Contractor shall document these efforts fully, and shall implement affirmative action steps at least as extensive as the following:
  - a. Ensure and maintain a working environment free of harassment, intimidation, and coercion at all sites, and in all facilities at which the Contractor's employees are assigned to work. The Contractor, where possible, will assign two or more women to each construction project. The Contractor shall specifically ensure that all foremen, superintendents, and other on-site supervisory personnel are aware of and carry out the Contractor's obligation to maintain such a working environment, with specific attention to minority or female individuals working at such sites or in such facilities.
  - b. Establish and maintain a current list of minority and female recruitment sources, provide written notification to minority and female recruitment sources and to community organizations when the Contractor or its unions have employment opportunities available, and maintain a record of the organizations' responses.
  - c. Maintain a current file of the names, addresses and telephone numbers of each minority and female off-the-street applicant and minority or female referral from a union, a recruitment source or community organization and of what action was taken with respect to each such individual. If such individual was sent to the union hiring hall for referral and was not referred back to the Contractor by the union or, if referred, not employed by the Contractor, this shall be documented in the file with the reason therefore, along with whatever additional actions the Contractor may have taken.
  - d. Provide immediate written notification to the Director when the union or unions with which the Contractor has a collective bargaining agreement has not referred to the Contractor a minority person or woman sent by the Contractor, or when the Contractor has other information that the union referral process has impeded the Contractor's efforts to meet its obligations.
  - e. Develop on-the-job training opportunities and/or participate in training programs for the area which expressly include minorities and women, including upgrading programs and apprenticeship and trainee programs relevant to the Contractor's employment needs,

#### AFFIRMATIVE ACTION REQUIREMENTS

especially those programs funded or approved by the Department of Labor. The Contractor shall provide notice of these programs to the sources compiled under 7b above.

- f. Disseminate the Contractor's EEO policy by providing notice of the policy to unions and training programs and requesting their cooperation in assisting the Contractor in meeting its EEO obligations; by including it in any policy manual and collective bargaining agreement; by publicizing it in the company newspaper, annual report, etc.; by specific review of the policy with all management personnel and with all minority and female employees at least once a year; and by posting the company EEO policy on bulletin boards accessible to all employees at each location where construction work is performed.
- g. Review, at least annually, the company's EEO policy and affirmative action obligations under these specifications with all employees having any responsibility for hiring, assignment, layoff, termination or other employment decisions including specific review of these items with onsite supervisory personnel such as Superintendents, General Foremen, etc., prior to the initiation of construction work at any job site. A written record shall be made and maintained identifying the time and place of these meetings, persons attending, subject matter discussed, and disposition of the subject matter.
- h. Disseminate the Contractor's EEO policy externally by including it in any advertising in the news media, specifically including minority and female news media, and providing written notification to and discussing the Contractor's EEO policy with other Contractors and Subcontractors with whom the Contractor does or anticipates doing business.
- i. Direct its recruitment efforts, both oral and written, to minority, female and community organizations, to schools with minority and female students and to minority and female recruitment and training organizations serving the Contractor's recruitment area and employment needs. Not later than one month prior to the date for the acceptance of applications for apprenticeship or other training by any recruitment source, the Contractor shall send written notification to organizations such as the above, describing the openings, screening procedures, and tests to be used in the selection process.
- j. Encourage present minority and female employees to recruit other minority persons and women and, where reasonable, provide after school, summer and vacation employment to minority and female youth both on the site and in other areas of a Contractor's work force.
- k. Validate all tests and other selection requirements where there is an obligation to do so under 41 CFR Part 60-3.

#### AFFIRMATIVE ACTION REQUIREMENTS

- l. Conduct, at least annually, an inventory and evaluation at least of all minority and female personnel for promotional opportunities and encourage these employees to seek or to prepare for, through appropriate training, etc., such opportunities.
  - m. Ensure that seniority practices, job classifications, work assignments and other personnel practices, do not have a discriminatory effect by continually monitoring all personnel and employment related activities to ensure that the EEO policy and the Contractor's obligations under these specifications are being carried out.
  - n. Ensure that all facilities and company activities are non-segregated except that separate or single-user toilet and necessary changing facilities shall be provided to assure privacy between the sexes.
  - o. Document and maintain a record of all solicitations of offers for subcontracts from minority and female construction contractors and suppliers, including circulation of solicitations to minority and female contractor associations and other business associations.
  - p. Conduct a review, at least annually, of all supervisors' adherence to and performance under the Contractor's EEO policies and affirmative action obligations.
8. Contractors are encouraged to participate in voluntary associations which assist in fulfilling one or more of their affirmative action obligations (7a through p). The efforts of a contractor association, joint contractor-union, contractor-community, or other similar group of which the contractor is a member and participant, may be asserted as fulfilling any one or more of its obligations under 7a through p of these Specifications provided that the contractor actively participates in the group, makes every effort to assure that the group has a positive impact on the employment of minorities and women in the industry, ensures that the concrete benefits of the program are reflected in the Contractor's minority and female workforce participation, makes a good faith effort to meet its individual goals and timetables, and can provide access to documentation which demonstrates the effectiveness of actions taken on behalf of the Contractor. The obligation to comply, however, is the Contractor's and failure of such a group to fulfill an obligation shall not be a defense for the Contractor's noncompliance.
9. A single goal for minorities and a separate single goal for women have been established. The Contractor, however, is required to provide equal employment opportunity and to take affirmative action for all minority groups, both male and female, and all women, both minority and non-minority. Consequently, the Contractor may be in violation of the Executive Order if a particular group is employed in a substantially disparate manner (for example, even though the Contractor has achieved its goals for women generally, the Contractor may be in violation of the Executive Order if a specific minority group of women is underutilized).

#### AFFIRMATIVE ACTION REQUIREMENTS

10. The Contractor shall not use the goals and timetables or affirmative action standards to discriminate against any person because of race, color, religion, sex, age, national origin, familial status, or disability.
11. The Contractor shall not enter into any Subcontract with any person or firm debarred from Government contracts pursuant to Executive Order 11246.
12. The Contractor shall carry out such sanctions and penalties for violation of these specifications and of the Equal Opportunity Clause, including suspension, termination and cancellation of existing subcontracts as may be imposed or ordered pursuant to Executive Order 11246, as amended, and its implementing regulations, by the Office of Federal Contract Compliance Programs. Any Contractor who fails to carry out such sanctions and penalties shall be in violation of these specifications and Executive Order 11246, as amended.
13. The Contractor, in fulfilling its obligations under these specifications, shall implement specific affirmative action steps, at least as extensive as those standards prescribed in paragraph 7 of these specifications, so as to achieve maximum results from its efforts to ensure equal employment opportunity. If the Contractor fails to comply with the requirements of the Executive Order, the implementing regulations, or these specifications, the Director shall proceed in accordance with 41 CFR 60-4.8.
14. The Contractor shall designate a responsible official to monitor all employment related activity to ensure that the company EEO policy is being carried out, to submit reports relating to the provisions hereof as may be required by the Government and to keep records. Records shall at least include for each employee the name, address, telephone numbers, construction trade, union affiliation if any, employee identification number when assigned, social security number, race, sex, status (e.g., mechanic, apprentice trainee, helper, or laborer), dates of changes in status, hours worked per week in the indicated trade, rate of pay, and locations at which the work was performed. Records shall be maintained in an easily understandable and retrievable form; however, to the degree that existing records satisfy this requirement, contractors shall not be required to maintain separate records.
15. Nothing herein provided shall be construed as a limitation upon the application of other laws which establish different standards of compliance or upon the application of requirements for the hiring of local or other area residents (e.g., those under the Public Works Employment Act of 1977 and the Community Development Block Grant Program).

#### AFFIRMATIVE ACTION REQUIREMENTS

## SPECIAL EQUAL OPPORTUNITY PROVISIONS FOR CONTRACTORS

Certain Federal contracts are exempt from coverage under the laws enforced by OFCCP.

A. Activities and Contracts Not Subject to Executive Order 11246, as Amended

Federal assisted construction contracts and related subcontracts valued at \$10,000 and under are exempt from coverage under the laws enforced by the OFCCP.

The applicant hereby agrees to incorporate or cause to be incorporated in any contract or subcontract the following equal opportunity clause:

During the performance of this contract, the contractor agrees as follows:

- (1) The Contractor shall not discriminate against any employee or applicant for employment because of race, color, religion, sex, age, national origin, familial status, or disability. The Contractor shall take affirmative action to ensure that applicants for employment are employed, and that employees are treated during employment, without regard to their race, color, religion, sex, age, national origin, familial status, or disability. Such action shall include, but not be limited to, the following: employment, upgrading, demotion, or transfer; recruitment or recruitment advertising; layoff or termination; rates of pay or other forms of compensation; and selection for training, including apprenticeship.
- (2) **The Contractor shall post in conspicuous places, available to employees and applicants for employment, notices to be provided by Contracting Officer setting forth the provisions of this non-discrimination clause.** The Contractor shall state that all qualified applicants will receive consideration for employment without regard to race, color, religion, sex, age, national origin, familial status, or disability.
- (3) Contractors shall incorporate foregoing requirements in all subcontracts.

B. Activities and Contracts subject to Executive Order (E.O.) 11246, as Amended

Federally assisted construction contractors are required by E.O. 11246 to take specific “good faith” affirmative action steps to increase the utilization of minorities and women in skilled trades. The following requirements are applicable to federally assisted construction contracts and related subcontracts above \$10,000.

The applicant hereby agrees to incorporate or cause to be incorporated in any contract or subcontract the following equal opportunity clause:

During the performance of this contract, the contractor agrees as follows:

### AFFIRMATIVE ACTION REQUIREMENTS

- (1) The contractor will not discriminate against any employee or applicant for employment because of race, color, religion, sex, age, national origin, familial status, or disability. The contractor will take affirmative action to ensure that applicants are employed, and that employees are treated during employment, without regard to their race, color, religion, sex, age, national origin, familial status, or disability. Such action shall include, but not be limited to the following: Employment, upgrading, demotion, or transfer; recruitment, or recruitment advertising; layoff or termination, rates of pay or other forms of compensation; and selection for training, including apprenticeship. The contractor agrees to post in conspicuous places, available to employees and applicants for employment, notices to be provided setting forth the provisions of this nondiscrimination clause.
- (2) The contractor will, in all solicitations or advertisements for employees placed by or on behalf of the contractor, state that all qualified applicants will receive consideration without regard to race, color, religion, sex, age, national origin, familial status, or disability.
- (3) The contractor will send to each labor union or representative of workers with which he has a collective bargaining agreement or other contract or understanding, a notice to be provided by the Contract Compliance Officer advising the said labor union or workers' representatives of the contractor's commitment under this section, and shall post copies of the notice in conspicuous places available to employees and applicants for employment.
- (4) The contractor will comply with all provisions of Executive Order 11246 of September 24, 1965, and of the rules, regulations, and relevant orders of the Secretary of Labor.
- (5) The contractor will furnish all information and reports required by Executive Order 11246 of September 24, 1965, and by rules, regulations, and orders of the Secretary of Labor, or pursuant thereto, and will permit access to his books, records, and accounts by the Department and the Secretary of Labor for purposes of investigation to ascertain compliance with such rules, regulations, and others.
- (6) In the event of the contractor's non-compliance with the non-discrimination clauses of this contract or with any of the said rules, regulations, or orders, this contract may be canceled, terminated, or suspended in whole or in part and the contractor may be declared ineligible for further Government contracts in accordance with procedures authorized in Executive Order 11246 of September 24, 1965, or by rule, regulation, or order of the Secretary of Labor, or as otherwise provided by law.
- (7) The contractor will include the provisions of the sentence immediately preceding paragraph (1) and the provisions of paragraphs (1) through (7) in every subcontract or purchase order unless exempted by rules, regulations, or orders of the Secretary of Labor issued pursuant to Section 204 of Executive Order 11246 of September 24, 1965, so that such provisions will be binding upon each subcontractor or vendor.

#### AFFIRMATIVE ACTION REQUIREMENTS

The contractor will take such action with respect to any subcontract or purchase order as the Department may direct as a means of enforcing such provisions, including sanctions for non-compliance. Provided, however, that in the event a contractor becomes involved in, or is threatened with, litigation with a subcontractor or vendor as a result of such direction by the Department, the contractor may request the United States to enter into such litigation to protect the interest of the United States.

The applicant further agrees that it will be bound by the above equal opportunity clause with, respect to its own employment practices when it participates in federally assisted construction work: Provided, that if the applicant so participating is a State or local government, the above equal opportunity clause is not applicable to any agency, instrumentality or subdivision of such government which does not participate in work on or under the contract.

The applicant agrees that it will assist and cooperate actively with the administering agency and the Secretary of Labor in obtaining the compliance of contractors and subcontractors with the equal opportunity clause and the rules, regulations, and relevant orders of the Secretary of Labor, that it will furnish the administering agency and the Secretary of Labor in obtaining the compliance of contractors and subcontractors with the equal opportunity clause and the rules, regulations, and relevant orders of the Secretary of Labor, that it will furnish the administering agency and the Secretary of Labor such information as they may require for the supervision of such compliance, and that it will otherwise assist the administering agency in the discharge of the agency's primary responsibility for securing compliance.

The applicant further agrees that it will refrain from entering into any contract or contract modification subject to Executive Order 11246 of September 24, 1965, with a contractor debarred from, or who has not demonstrated eligibility for Government contracts and federally assisted construction contracts pursuant to the Executive Order and will carry out such sanctions and penalties for violation of the equal opportunity clause as may be imposed upon contractors and subcontractors by the administering agency or the Secretary of Labor pursuant to Part II, Subpart D of the Executive Order. In addition, the applicant agrees that if it fails or refuses to comply with these undertakings, the administering agency may take any or all of the following actions: Cancel, terminate, or suspend in whole or in part this grant (contract, loan, insurance, guarantee), refrain from extending any further assistance to the applicant under the program with respect to which the failure or refund occurred until satisfactory assurance of future compliance has been received from such applicant, and refer the case to the Department of Justice for appropriate legal proceedings.

#### AFFIRMATIVE ACTION REQUIREMENTS

## **Civil Rights, Employment and Contracting Opportunities, and Other Federal Requirements**

**Americans with Disabilities Act of 1990 (ADA):** This Act modifies and expands the Rehabilitation Act of 1973 to prohibit discrimination against “a qualified individual with a disability” in employment and public accommodations. The ADA requires that an individual with a physical or mental impairment who is otherwise qualified to perform the essential functions of a job, with or without reasonable accommodation, be afforded equal employment opportunity in all phases of employment.

**Architectural Barriers Act of 1968 (ABA) - (42 U.S.C. 4151-4157):** This Act requires that certain buildings financed with Federal funds must be designed, constructed, or altered in accordance with standards that ensure accessibility for persons with physical disabilities. The ABA covers any building or facility financed in whole or in part with Federal funds, except privately owned residential structures. Covered buildings and facilities designed, constructed, or altered with CDBG funds are subject to the ABA and must comply with the Uniform Federal Accessibility Standards.

**Disadvantaged Business Enterprises (DBE):** It is the policy of HUD to encourage the award of prime contracts valued at \$100,000 or more to small disadvantaged business (SDB) concerns (other than certified 8(a) firms) that are at least 51 percent owned and controlled by socially and economically disadvantaged individuals.

**Fair Labor Standards Act (FLSA) [as amended] - 29 U.S.C. 201 et seq.:** The U.S. Department of Labor (DOL) administers and enforces the minimum wage, overtime pay, recordkeeping, and youth employment standards affecting employees in the private sector and in Federal, State, and local governments.

**Immigration Reform and Control Act (IRCA) of 1986:** Employers may hire only persons who may legally work in the U.S., i.e., citizens and nationals of the U.S. and aliens authorized to work in the U.S. The employer must verify the identity and employment eligibility of anyone to be hired, which includes completing the Employment Eligibility Verification Form (I-9).

**Minority and Women-Owned Business Enterprises (MBE/WBE) - 24CFR Part 85.36 (e) (1):** It is the policy of HUD to actively encourage contractors to take all necessary affirmative steps to assure that small and minority firms, Women’s business enterprise and labor surplus area firms as used as subcontractors when possible. A minority or women-owned



small business concern is defined as owned by at least 51 percent minority group members or women.

**Section 109 of Title 1 of the Housing and Community Development Act of 1974, as amended (42 U.S.C. 5301 et. seq., particularly 42 U.S.C. 6101 et. seq., and 29 U.S.C. 794):** This section provides that no person shall be excluded from participation (including employment), denied program benefits, or subject to discrimination on the basis of race, color, national origin, or sex under any program or activity funded in whole or in part under Title 1 of the Act.

**Section 504 of the Rehabilitation Act of 1973, as amended (implemented at 24 CFR Part 135):** It is unlawful to discriminate based on disability in federally assisted programs. This section provides that no otherwise qualified individual shall, solely by reason of his or her disability, be excluded from participation (including employment), denied program benefits, or subjected to discrimination under any program or activity receiving Federal funding assistance. Section 504 also contains design and construction accessibility provisions for multi-family dwellings developed or substantially rehabilitated for first occupancy on or after March 13, 1991.

**Uniform Guidelines on Employee Selection Procedures adopted by the Equal Employment Opportunity Commission in 1978:** This manual applies to employee selection procedures in the areas of hiring, retention, promotions, transfer, demotions, dismissal, and referral. It is designed to assist employers, labor organizations, employment agencies, licensing and certification boards in complying with the requirements of Federal laws prohibiting discriminatory employment.

**Vietnam Era Veterans' Readjustment Act of 1974 (revised Jobs for Veterans Act of 2002):** This Act was passed to ensure equal employment opportunity for qualified disabled veterans and veterans of the Vietnam War. Affirmative action is required in the hiring and promotion of veterans.

**Violation or Breach of Contract:** Contracts for more than the simplified acquisition threshold currently set at \$150,000, which is the inflation adjusted amount determined by the Civilian Agency Acquisition Council and the Defense Acquisition Regulations Council (Councils) as authorized by 41 U.S.C. 1908, must address administrative, contractual, or legal remedies in instances where contractors violate or breach contract terms, and provide for such sanctions and penalties as appropriate.

**Termination for Cause and for Convenience:** All contracts in excess of \$10,000 must address termination for cause and for convenience by the

non-Federal entity including the manner by which it will be effected and the basis for settlement.

**Rights to Inventions Made Under a Contract or Agreement:** If the agreement with the contractor is for the performance of experimental, developmental, or research work, including any assignment, substitution of parties, or subcontract of any type entered into for such purpose, the recipient or subrecipient must comply with the requirements of 37 CFR Part 401, “Rights to Inventions Made by Nonprofit Organizations and Small Business Firms Under Government Grants, Contracts and Cooperative Agreements,” and any implementing regulations issued by the awarding agency.

**Clean Air Act (42 U.S.C. 7401-7671q.) and the Federal Water Pollution Control Act (33 U.S.C. 1251-1387), as amended:** Contracts and subgrants of amounts in excess of \$150,000 must contain a provision that requires the non-Federal award to agree to comply with all applicable standards, orders or regulations issued pursuant to the Clean Air Act (42 U.S.C. 7401-7671q) and the Federal Water Pollution Control Act as amended (33 U.S.C. 1251-1387). Violations must be reported to the Federal awarding agency and the Regional Office of the Environmental Protection Agency (EPA).

**Procurement of Recovered Materials:** A non-Federal entity that is a state agency or agency of a political subdivision of a state and its contractors must comply with section 6002 of the Solid Waste Disposal Act, as amended by the Resource Conservation and Recovery Act. The requirements of Section 6002 include procuring only items designated in guidelines of the Environmental Protection Agency (EPA) at 40 CFR part 247 that contain the highest percentage of recovered materials practicable, consistent with maintaining a satisfactory level of competition, where the purchase price of the item exceeds \$10,000 or the value of the quantity acquired during the preceding fiscal year exceeded \$10,000; procuring solid waste management services in a manner that maximizes energy and resource recovery; and establishing an affirmative procurement program for procurement of recovered materials identified in the EPA guidelines.

# The Davis-Bacon Act, as Amended



---

U.S. Department of Labor  
Employment Standards Administration  
Wage and Hour Division

WH Publication 1246  
(Revised April 2009)

Materials contained in this publication is in the public domain and may be reproduced, fully or partially, without permission of the federal Government. Source credit is requested but not required. Permission is required only to reproduce any copyrighted material contained herein.

This material will be made available to Sensory impaired individuals upon request. Voice phone: 202-693-0675 TDD\* phone: 202-523-9530

An Act

To revise, codify, and enact without substantive change certain general and permanent laws, related to public buildings, property, and works, as title 40, United States Code, “Public Buildings, Property, and Works”.

Be it enacted by the Senate and House of Representatives of the United States of America in Congress assembled,

SECTION 1. TITLE 40, UNITED STATES CODE.

Certain general and permanent laws of the United States, related to public buildings, property, and works, are revised, codified, and enacted as title 40, United States Code, “Public Buildings, Property, and Works”, as follows:

TITLE 40—PUBLIC BUILDINGS, PROPERTY, AND WORKS

\* \* \* \*

SUBTITLE II—PUBLIC BUILDINGS AND WORKS

PART A—GENERAL

\* \* \* \*

CHAPTER 31 – GENERAL

\* \* \* \*

SUBCHAPTER IV - WAGE RATE REQUIREMENTS

Sec. 3141. Definitions

In this subchapter, the following definitions apply:

- (1) Federal government.— The term “Federal Government” has the same meaning that the term “United States” had in the Act of March 3, 1931 (ch. 411, 46 Stat. 1494) (known as the Davis-Bacon Act).<sup>2</sup>
(2) Wages, scale of wages, wage rates, minimum wages, and prevailing wages.— The terms “wages”, “scale of wages”, “wage rates”, “minimum wages”, and “prevailing wages” include—
(A) the basic hourly rate of pay; and

<sup>1</sup>Pub. L. 109-284 Sec. 6(11), (12), and (13) made three minor technical corrections in Secs 3141(1), and 3142(d) and (e). (Sept. 27, 2006, 120 Stat.1213.)
<sup>2</sup>The Davis-Bacon Act, referred to in par. (1), is act of Mar. 3, 1931, ch. 411, 46 Stat. 1494, as amended, which was classified generally to sections 276a to 276a-5 of former Title 40, Public Buildings, Property, and Works, and was repealed and reenacted as sections 3141-3144, 3146, and 3147 of this title by Pub. L. 107-217, Secs. 1, 6(b), Aug. 21, 2002, 116 Stat. 1062, 1304.

(B) for medical or hospital care, pensions on retirement or death, compensation for injuries or illness resulting from occupational activity, or insurance to provide any of the forgoing, for unemployment benefits, life insurance, disability and sickness insurance, or accident insurance, for vacation and holiday pay, for defraying the costs of apprenticeship or other similar programs, or for other bona fide fringe benefits, but only where the contractor or subcontractor is not required by other federal, state, or local law to provide any of those benefits, the amount of—

(i) the rate of contribution irrevocably made by a contractor or subcontractor to a trustee or to a third person under a fund, plan, or program; and

(ii) the rate of costs to the contractor or subcontractor that may be reasonably anticipated in providing benefits to laborers and mechanics pursuant to an enforceable commitment to carry out a financially responsible plan or program which was communicated in writing to the laborers and mechanics affected.

### **Sec. 3142. Rate of wages for laborers and mechanics**

(a) Application.— The advertised specifications for every contract in excess of \$2,000, to which the Federal Government or the District of Columbia is a party, for construction, alteration, or repair, including painting and decorating, of public buildings and public works of the Government or the District of Columbia that are located in a State or the District of Columbia and which requires or involves the employment of mechanics or laborers shall contain a provision stating the minimum wages to be paid various classes of laborers and mechanics.

(b) Based on Prevailing Wage.— The minimum wages shall be based on the wages the Secretary of Labor determines to be prevailing for the corresponding classes of laborers and mechanics employed on projects of a character similar to the contract work in the civil subdivision of the State in which the work is to be performed, or in the District of Columbia if the work is to be performed there.

(c) Stipulations Required in Contract.— Every contract based upon the specifications referred to in subsection (a) must contain stipulations that—

(1) the contractor or subcontractor shall pay all mechanics and laborers employed directly on the site of the work, unconditionally and at least once a week, and without subsequent deduction or rebate on any account, the full amounts accrued at time of payment, computed at wage rates not less than those stated in the advertised specifications, regardless of any contractual relationship which may be alleged to exist between the contractor or subcontractor and the laborers and mechanics;

(2) the contractor will post the scale of wages to be paid in a prominent and easily accessible place at the site of the work; and

(3) there may be withheld from the contractor so much of accrued payments as the contracting officer considers necessary to pay to laborers and mechanics employed by the contractor or any subcontractor on the work the difference between the rates of wages required by the contract to be paid laborers and mechanics on the work and the rates of wages received by the laborers and mechanics and not refunded to the contractor or subcontractors or their agents.

(d) Discharge of Obligation.— The obligation of a contractor or subcontractor to make payment in accordance with the prevailing wage determinations of the Secretary of Labor, under this subchapter and other laws incorporating this subchapter by reference, may be discharged by making payments in cash, by making contributions described in section 3141(2)(B)(i) of this title, by assuming an enforceable commitment to bear the costs of a plan or program referred to in section 3141(2)(B)(ii) of this title, or by any combination of payment, contribution, and assumption, where the aggregate of the payments, contributions, and costs is not less than the basic hourly rate of pay plus the amount referred to in section 3141(2)(B) of this title.

(e) Overtime Pay.— In determining the overtime pay to which a laborer or mechanic is entitled under any federal law, the regular or basic hourly rate of pay (or other alternative rate on which premium rate of overtime compensation is computed) of the laborer or mechanic is deemed to be the rate computed under section 3141(2)(A) of this title, except that where the amount of payments, contributions, or costs incurred with respect to the laborer or mechanic exceeds the applicable prevailing wage, the regular or basic hourly rate of pay (or other alternative rate) is the amount of payments, contributions, or costs actually incurred with respect to the laborer or mechanic minus the greater of the amount of contributions or costs of the types described in section 3141(2)(B) of this title actually incurred with respect to the laborer or mechanic or the amount determined under section 3141(2)(B) of this title but not actually paid.

### **Sec.3143. Termination of work on failure to pay agreed wages**

Every contract within the scope of this subchapter shall contain a provision that if the contracting officer finds that any laborer or mechanic employed by the contractor or any subcontractor directly on the site of the work covered by the contract has been or is being paid a rate of wages less than the rate of wages required by the contract to be paid, the Federal Government by written notice to the contractor may terminate the contractor's right to proceed with the work or the part of the work as to which there has been a failure to pay the required wages. The Government may have the work completed, by contract or otherwise, and the contractor and the contractor's sureties shall be liable to the Government for any excess costs the Government incurs.

### **Sec. 3144. Authority of Comptroller General to pay wages and list contractors violating contracts**

(a) Payment of Wages.—

(1) In general.— The Comptroller General shall pay directly to laborers and mechanics from any accrued payments withheld under the terms of a contract any wages found to be due laborers and mechanics under this subchapter.

(2) Right of action.— If the accrued payments withheld under the terms of the contract are insufficient to reimburse all the laborers and mechanics who have not been paid the wages required under this subchapter, the laborers and mechanics have the same right to bring a civil action and intervene against the contractor and the contractor's sureties as is conferred by law on persons furnishing labor or materials. In those proceedings it is not a

defense that the laborers and mechanics accepted or agreed to accept less than the required rate of wages or voluntarily made refunds.

(b) List of Contractors Violating Contracts.—

(1) In general.— The Comptroller General shall distribute to all departments of the Federal Government a list of the names of persons whom the Comptroller General has found to have disregarded their obligations to employees and subcontractors.

(2) Restriction on awarding contracts.— No contract shall be awarded to persons appearing on the list or to any firm, corporation, partnership, or association in which the persons have an interest until three years have elapsed from the date of publication of the list.

\* \* \* \*

**Sec. 3146. Effect on other federal laws**

This subchapter does not supersede or impair any authority otherwise granted by federal law to provide for the establishment of specific wage rates.

**Sec. 3147. Suspension of this subchapter during a national emergency**

The President may suspend the provisions of this subchapter during a national emergency.

**Sec. 3148. Application of this subchapter to certain contracts**

This subchapter applies to a contract authorized by law that is made without regard to section 3709 of the Revised Statutes (41 U.S.C. 5), or on a cost-plus-a-fixed-fee basis or otherwise without advertising for proposals, if this subchapter otherwise would apply to the contract.

## DAVIS-BACON REQUIREMENT

### POSTING THE WAGE DECISION AND NOTICE TO EMPLOYEES

The Contractor is required to display on the job site a copy of the applicable Davis-Bacon wage decision and the form WH-1321 ([fedprojc.pdf \(dol.gov\)](#)). *Notice to Employees*.

The purpose of this posting is to provide information to the construction laborers and mechanics working on the project about their entitlement to the prevailing wage rate for their trade and to inform them of who to contact (the contract administrator) if they have any questions or want to file a complaint. The Department of Housing and Urban Development (HUD) also has prepared a pamphlet explaining the rights of workers to be paid prevailing wages in which you may make available to laborers and mechanics on the job site or through mailings.

The wage decision and form WH-1321 must be posted in a location readily accessible to all employees, i.e., not inside a construction trailer or vehicle.

# EMPLOYEE RIGHTS

## UNDER THE DAVIS-BACON ACT

### FOR LABORERS AND MECHANICS EMPLOYED ON FEDERAL OR FEDERALLY ASSISTED CONSTRUCTION PROJECTS

#### PREVAILING WAGES

You must be paid not less than the wage rate listed in the Davis-Bacon Wage Decision posted with this Notice for the work you perform.

#### OVERTIME

You must be paid not less than one and one-half times your basic rate of pay for all hours worked over 40 in a work week. There are few exceptions.

#### ENFORCEMENT

Contract payments can be withheld to ensure workers receive wages and overtime pay due, and liquidated damages may apply if overtime pay requirements are not met. Davis-Bacon contract clauses allow contract termination and debarment of contractors from future federal contracts for up to three years. A contractor who falsifies certified payroll records or induces wage kickbacks may be subject to civil or criminal prosecution, fines and/or imprisonment.

#### APPRENTICES

Apprentice rates apply only to apprentices properly registered under approved Federal or State apprenticeship programs.

#### PROPER PAY

If you do not receive proper pay, or require further information on the applicable wages, contact the Contracting Officer listed below:

or contact the U.S. Department of Labor's Wage and Hour Division.



WAGE AND HOUR DIVISION  
UNITED STATES DEPARTMENT OF LABOR

1-866-487-9243  
TTY: 1-877-889-5627  
[www.dol.gov/whd](http://www.dol.gov/whd)





# DERECHOS DEL EMPLEADO BAJO LA LEY DAVIS-BACON

## PARA OBREROS Y MECÁNICOS EMPLEADOS EN PROYECTOS DE CONSTRUCCIÓN FEDERAL O CON ASISTENCIA FEDERAL

### **SALARIOS PREVALECIENTES**

No se le puede pagar menos de la tasa de pago indicada en la Decisión de Salarios Davis-Bacon fijada con este Aviso para el trabajo que Ud. desempeña.

### **SOBRETIEMPO**

Se le ha de pagar no menos de tiempo y medio de su tasa básica de pago por todas las horas trabajadas en exceso de 40 en una semana laboral. Existen pocas excepciones.

### **CUMPLIMIENTO**

Se pueden retener pagos por contratos para asegurarse que los obreros reciban los salarios y el pago de sobretiempo debidos, y se podría aplicar daños y perjuicios si no se cumple con las exigencias del pago de sobretiempo. Las cláusulas contractuales de Davis-Bacon permiten la terminación y exclusión de contratistas para efectuar futuros contratos federales hasta tres años. El contratista que falsifique los registros certificados de las nóminas de pago o induzca devoluciones de salarios puede ser sujeto a procesamiento civil o criminal, multas y/o encarcelamiento.

### **APRENDICES**

Las tasas de aprendices sólo se aplican a aprendices correctamente inscritos bajo programas federales o estatales aprobados.

### **PAGO APROPIADO**

Si Ud. no recibe el pago apropiado, o precisa de información adicional sobre los salarios aplicables, póngase en contacto con el Contratista Oficial que aparece abajo:

o póngase en contacto con la División de Horas y Salarios del Departamento de Trabajo de los EE.UU.



**DIVISIÓN DE HORAS Y SALARIOS**  
DEPARTAMENTO DE TRABAJO DE LOS EE.UU.

1-866-487-9243  
TTY: 1-877-889-5627  
[www.dol.gov/whd](http://www.dol.gov/whd)





U.S. Department of Housing  
and Urban Development

Labor Relations Desk Guide  
LR01.DG

# DAVIS-BACON

## LABOR STANDARDS

*A Contractor's Guide  
to Prevailing Wage Requirements  
for Federally-Assisted Construction Projects*

*January 2012  
Previous versions obsolete*





---

## INTRODUCTION

This Guide has been prepared for you as a contractor performing work on construction projects that are assisted by the Department of Housing and Urban Development and subject to Davis-Bacon prevailing wage requirements. This Guide does not address contractor requirements involved in direct Federal contracting where HUD or another Federal agency enters into a procurement contract. In this latter case, the Federal Acquisition Regulations (FAR) are applicable. While the guidance contained in this Guide is generally applicable to any Davis-Bacon covered project, specific questions pertaining to direct Federal contracts should be addressed to the Contracting Officer who signed the contract for the Federal agency.

Our objective here is to provide you with a guide which is simple and non-bureaucratic yet comprehensive and which will help you better understand and comply with Davis-Bacon labor standards. HUD's Office of Labor Relations worked closely with the Department of Labor's Wage and Hour Division to make sure that the labor standards provisions in your contract and the specifics of complying with them represent the latest information. It is the Department of Labor which has general administrative oversight of all Federal contracting agencies, such as HUD, which administer the day-to-day responsibilities of enforcing Davis-Bacon provisions in construction contracts they either fund or assist in funding.

There are three chapters in this Guide. The first chapter offers a brief description of the laws and regulations associated with Federal labor standards administration and enforcement and discusses both what's in your contract that requires Davis-Bacon compliance and your responsibilities. The second chapter deals with labor standards and payroll reporting requirements. The third chapter discusses what can happen in the event there is a dispute about the wage rates that should be (or have been) paid and any back wages that may be due.

Finally, not all HUD construction projects are covered by Davis-Bacon wage rates. For the purpose of this Guide, we are assuming that a determination has already been made that Davis-Bacon wage rates are applicable. Should you wish assistance in determining whether Davis-Bacon wage rates apply to a particular project or if you need other related technical assistance, please consult with the HUD Labor Relations Field staff for your area. If you don't know which staff to contact, a list of Labor Relations field offices and their geographic areas and telephone numbers can be found on HUD's Home Page at the address below.

**Visit the Office of Labor Relations on-line:**

<http://www.hud.gov/offices/olr>

Obtain additional copies of this Guide and other publications at our website or by telephone from HUD's Customer Service Center at (800)767-7468.



---

# TABLE OF CONTENTS

**INTRODUCTION** ..... i

**CHAPTER 1 LAWS, REGULATIONS, CONTRACTS AND RESPONSIBILITIES** ..... 1-1

**1-1 DAVIS-BACON AND OTHER LABOR LAWS** ..... 1-1

    a. The Davis-Bacon Act (DBA) ..... 1-1

    b. The Contract Work Hours and Safety Standards Act (CWHSSA) ..... 1-1

    c. The Copeland Act (Anti-Kickback Act) ..... 1-2

    d. The Fair Labor Standards Act (FLSA) ..... 1-2

**1-2 DAVIS-BACON REGULATIONS** ..... 1-2

**1-3 CONSTRUCTION CONTRACT PROVISIONS** ..... 1-2

**1-4 RESPONSIBILITY OF THE PRINCIPAL CONTRACTOR** ..... 1-3

**1-5 RESPONSIBILITY OF THE CONTRACT ADMINISTRATOR** ..... 1-4

**CHAPTER 2 HOW TO COMPLY WITH LABOR STANDARDS AND PAYROLL REPORTING REQUIREMENTS** ..... 2-1

## SECTION - I THE BASICS

**2-1 THE WAGE DECISION** ..... 2-1

    a. The work classifications and wage rates ..... 2-1

    b. Posting the wage decision ..... 2-2

**2-2 ADDITIONAL “TRADE” CLASSIFICATIONS AND WAGE RATES** ..... 2-2

    a. Additional classification rules ..... 2-2

    b. Making the request ..... 2-3

    c. HUD review ..... 2-3

    d. DOL decision ..... 2-3

**2-3 CERTIFIED PAYROLL REPORTS** ..... 2-4

    a. Payroll formats ..... 2-4

    b. Payroll certifications ..... 2-4

    c. “No work” payrolls ..... 2-4

    d. Payroll review and submission ..... 2-5

    e. Payroll retention ..... 2-5

    f. Payroll inspection ..... 2-5

**2-4 DAVIS-BACON DEFINITIONS** ..... 2-5

    a. Laborer or mechanic ..... 2-5

    b. Employee ..... 2-6

    c. Apprentices and trainees ..... 2-6

    d. Prevailing wages or wage rates ..... 2-7

    e. Fringe benefits ..... 2-7

    f. Overtime ..... 2-7

    g. Deductions ..... 2-8

    h. Proper designation of trade ..... 2-8

    i. Site of work ..... 2-8

---

## SECTION - II REPORTING REQUIREMENT

<b>2-5</b>	<b>COMPLETING A PAYROLL REPORT</b> .....	2-9
	a. Project and contractor/subcontractor information.....	2-9
	b. Employee information.....	2-9
	c. Work classification.....	2-9
	d. Hours worked .....	2-10
	e. Rate of pay .....	2-10
	f. Gross wages earned .....	2-10
	g. Deductions .....	2-11
	h. Net pay .....	2-11
	i. Statement of compliance.....	2-11
	j. Signature .....	2-11

## SECTION III - PAYROLL REVIEWS AND CORRECTIONS

<b>2-6</b>	<b>COMPLIANCE REVIEWS</b> .....	2-12
	a. On-site interviews.....	2-12
	b. Project payroll reviews .....	2-12
<b>2-7</b>	<b>TYPICAL PAYROLL ERRORS AND REQUIRED CORRECTIONS</b> .....	2-12
	a. Inadequate payroll information .....	2-12
	b. Missing identification numbers .....	2-12
	c. Incomplete payrolls .....	2-13
	d. Classifications .....	2-13
	e. Wage Rates.....	2-13
	f. Apprentices and trainees.....	2-13
	g. Overtime.....	2-13
	h. Computations .....	2-13
	i. Deductions .....	2-13
	j. Fringe benefits.....	2-14
	k. Signature .....	2-14
	l. On-site interview comparisons .....	2-14
	m. Correction certified payroll.....	2-14
<b>2-8</b>	<b>RESTITUTION FOR UNDERPAYMENT OF WAGES</b> .....	2-14
	a. Notification.....	2-14
	b. Computing wage restitution.....	2-15
	c. Correction certified payrolls.....	2-15
	d. Review of correction CPR .....	2-15
	e. Unfound workers .....	2-15

---

**CHAPTER 3      LABOR STANDARDS DISPUTES, ADMINISTRATIVE  
REVIEWS, WITHHOLDING, DEPOSITS AND ESCROW  
ACCOUNTS, AND SANCTIONS ..... 3-1**

**3-1    INTRODUCTION ..... 3-1**  
**3-2    ADMINISTRATIVE REVIEW ON LABOR STANDARDS DISPUTES ..... 3-1**  
    a. Additional classifications and wage rates ..... 3-1  
    b. Findings of underpayment ..... 3-2  
**3-3    WITHHOLDING ..... 3-2**  
**3-4    DEPOSITS AND ESCROWS ..... 3-3**  
**3-5    ADMINISTRATIVE SANCTIONS ..... 3-4**  
    a. DOL debarment ..... 3-4  
    b. HUD sanctions ..... 3-4  
**3-6    FALSIFICATION OF CERTIFIED PAYROLL REPORTS ..... 3-5**

**APPENDICIES**

**ACRONYMS AND SYMBOLS ..... A-1**  
**DAVIS-BACON - RELATED WEB SITES\* ..... A-2**  
**HUD-4720, Project Wage Rate Sheet ..... A-3**  
**WH-347, Payroll Form/Statement of Compliance ..... A-4**





---

## CHAPTER 1 LAWS, REGULATIONS, CONTRACTS AND RESPONSIBILITIES

The following paragraphs describe what the labor standards laws and regulations actually say and what they mean to you on HUD projects:

### 1-1 DAVIS-BACON AND OTHER LABOR LAWS.

- a. **The Davis-Bacon Act (DBA).** The Davis-Bacon Act requires the payment of prevailing wage rates (which are determined by the U.S. Department of Labor) to all laborers and mechanics on Federal government and District of Columbia construction projects in excess of \$2,000. Construction includes alteration and/or repair, including painting and decorating, of public buildings or public works.

Most HUD construction work is not covered by the DBA itself since HUD seldom contracts directly for construction services. Most often, if Davis-Bacon wage rates apply to a HUD project it is because of a labor provision contained in one of HUD's "Related Acts" such as the U. S. Housing Act of 1937, the National Housing Act, the Housing and Community Development Act of 1974, the National Affordable Housing Act of 1990, and the Native American Housing Assistance and Self-Determination Act of 1996. The Related Acts are often referred to as the Davis-Bacon and Related Acts or DBRA.

- b. **The Contract Work Hours and Safety Standards Act (CWHSSA).** CWHSSA requires time and one-half pay for overtime (O/T) hours (over 40 in any workweek) worked on the covered project. The CWHSSA applies to both direct Federal contracts and to indirect Federally-assisted contracts **except** where the assistance is solely in the nature of a loan guarantee or insurance. CWHSSA violations carry a liquidated damages penalty (\$10/day per violation). Intentional violations of CWHSSA standards can be considered for Federal criminal prosecution.

CWHSSA does not apply to prime contracts of \$100,000 or less. In addition, some HUD projects are not covered by CWHSSA because some HUD programs only provide loan guarantees or insurance. CWHSSA also does not apply to construction or rehabilitation contracts that are not subject to Federal prevailing wage rates (e.g., Davis-Bacon wage rates, or HUD-determined rates for operation of public housing and Indian block grant-assisted housing). However, even though CWHSSA overtime pay is not required, Fair Labor Standards Act (FLSA) overtime pay is probably still applicable. (See also Labor Relations Letter SL-95-01, CWHSSA Coverage threshold for overtime and health and safety provision, available on-line at the HUD Labor Relations Library at: [www.hud.gov/offices/olr/library.cfm](http://www.hud.gov/offices/olr/library.cfm))

- 
- c. **The Copeland Act (Anti-Kickback Act).** The Copeland Act makes it a Federal crime for anyone to require any laborer or mechanic (employed on a Federal or Federally-assisted project) to kickback (i.e., give up or pay back) any part of their wages. The Copeland Act requires every employer (contractors and subcontractors) to submit weekly certified payroll reports (CPRs) and regulates permissible payroll deductions.
  - d. **The Fair Labor Standards Act (FLSA).** The FLSA contains Federal minimum wage rates, overtime (O/T), and child labor requirements. These requirements generally apply to any labor performed. The DOL has the authority to administer and enforce FLSA. HUD will refer to the DOL any possible FLSA violations that are found on HUD projects.

## **1-2 DAVIS-BACON REGULATIONS.**

The Department of Labor (DOL) has published rules and instructions concerning Davis-Bacon and other labor laws in the Code of Federal Regulations (CFR). These regulations can be found in ***Title 29 CFR Parts 1, 3, 5, 6 and 7.*** Part 1 explains how the DOL establishes and publishes DBA wage determinations (aka wage decisions) and provides instructions on how to use the determinations. Part 3 describes Copeland Act requirements for payroll deductions and the submission of weekly certified payroll reports. Part 5 covers the labor standards provisions that are in your contract relating to Davis-Bacon Act wage rates and the responsibilities of contractors and contracting agencies to administer and enforce the provisions. Part 6 provides for administrative proceedings enforcing Federal labor standards on construction and service contracts. Last, Part 7 sets parameters for practice before the Administrative Review Board. These regulations are used as the basis for administering and enforcing the laws.

DOL Regulations are available on-line on the World Wide Web:  
[http://www.dol.gov/dol/allcfr/Title\\_29.htm](http://www.dol.gov/dol/allcfr/Title_29.htm)

## **1-3 CONSTRUCTION CONTRACT PROVISIONS**

Each contract subject to Davis-Bacon labor standards requirements must contain labor standards clauses and a Davis-Bacon wage decision. These documents are normally bound into the contract specifications.

- a. The labor standards clauses. The labor standards clauses describe the responsibilities of the contractor concerning Davis-Bacon wages and obligate the contractor to comply with the labor requirements. The labor standards clauses also provide for remedies in the event of violations, including withholding from payments due to the contractor to ensure the payment of wages or liquidated damages which may be found due. These contract clauses enable the contract administrator to enforce the Federal labor standards applicable to the project. HUD has standard forms that contain contract clauses. For example, the HUD-2554, Supplementary Conditions to the Contract for Construction, which is issued primarily for FHA multifamily housing and other construction projects

---

administered by HUD; the HUD-4010, Federal Labor Standards Provisions, which is used for CDBG and HOME projects, and the HUD-5370, General Conditions of the Contract for Construction or the HUD-5370-EZ (construction contracts ≤\$100,000) which are used for Public and Indian Housing projects.

HUD program labor standards forms are available on-line at:  
[www.hud.gov/offices/adm/hudclips/index.cfm](http://www.hud.gov/offices/adm/hudclips/index.cfm)

- b. Davis-Bacon Wage Decisions. The Davis-Bacon wage decision (or wage determination) is a listing of various construction work classifications, such as Carpenter, Electrician, Plumber and Laborer, and the minimum wage rates (and fringe benefits, where prevailing) that people performing work in those classifications must be paid.

Davis-Bacon wage decisions are established by the DOL for various types of construction (e.g., residential, heavy, highway) and apply to specific geographic areas, usually a county or group of counties. Wage decisions are modified from time to time to keep them current. In most cases, when the contract is awarded or when construction begins, the wage decision is “locked-in” and no future modifications are applicable to the contract or project involved.

All current Davis-Bacon wage decisions can be accessed on-line at no cost at:  
<http://www.wdol.gov>

#### **1-4 RESPONSIBILITY OF THE PRINCIPAL CONTRACTOR**

The principal contractor (also referred to as the ***prime*** or ***general contractor***) is responsible for the full compliance of all employers (the contractor, subcontractors and any lower-tier subcontractors) with the labor standards provisions applicable to the project. Because of the contractual relationship between a prime contractor and his/her subcontractors, subcontractors generally should communicate with the contract administrator only through the prime contractor. (See Contract Administrator, below.)

To make this Guide easier to understand, the term “prime contractor” will mean the principal contractor; “subcontractor” will mean all subcontractors including lower-tier subcontractors; and the term “employer” will mean all contractors as a group, including the prime contractor and any subcontractors and lower-tier subcontractors.

---

## 1-5 RESPONSIBILITY OF THE CONTRACT ADMINISTRATOR.

The **contract administrator** is responsible for the proper administration and enforcement of the Federal labor standards provisions on contracts covered by Davis-Bacon requirements. We use this term to represent the person (or persons) who will provide labor standards advice and support to you and other project principals (e.g., the owner, sponsor, architect), including providing the proper Davis-Bacon wage decision (see 2-1, **The Wage Decision**) and ensuring that the wage decision and contract clauses are incorporated into the contract for construction. The contract administrator also monitors labor standards compliance (see 2-6, **Compliance Reviews**) by conducting interviews with construction workers at the job site and reviewing payroll reports, and oversees any enforcement actions that may be required.

The contract administrator could be an employee or agent of HUD, or of a city or county or public housing agency. For HUD projects administered directly by HUD staff, usually FHA-insured multifamily projects, the contract administrator will be the HUD Labor Relations field staff. But many HUD-assisted projects are administered by local contracting agencies such as Public Housing Agencies (PHAs), Indian tribes and tribally-designated housing entities (TDHEs), and States, cities and counties under HUD's Community Development Block Grant (CDBG) and HOME programs. In these cases, the contract administrator will likely be local agency staff. In either case, the guidance for you remains essentially the same.

The DOL also has a role in monitoring Davis-Bacon administration and enforcement. In addition, DOL has independent authority to conduct investigations. A DOL investigator or other DOL representative may visit Davis-Bacon construction sites to interview construction workers or review payroll information.

---

## CHAPTER 2    HOW TO COMPLY WITH LABOR STANDARDS AND PAYROLL REPORTING REQUIREMENTS

**WHERE TO START?**    Now that you know you're on a Davis-Bacon project and you know some of the legal and practical implications, what's next?

### SECTION I - THE BASICS

#### 2-1    **THE WAGE DECISION.**

Davis-Bacon labor standards stipulate the wage payment requirements for Carpenters, Electricians, Plumbers, Roofers, Laborers, and other construction work classifications that may be needed for the project. The Davis-Bacon wage decision that applies to the project contains a schedule of work classifications and wage rates that must be followed. If you don't have it already (and by now you should), you'll want to get a copy of the applicable Davis-Bacon wage decision.

Remember, the wage decision is contained in the contract specifications along with the labor standards clauses. See 1-3, Construction Contract Provisions.

- a. **The work classifications and wage rates.** A Davis-Bacon wage decision is simply a listing of different work classifications and the minimum wage rates that must be paid to anyone performing work in those classifications. You'll want to make sure that the work classification(s) you need are contained in the wage decision and make certain you know exactly what wage rate(s) you will need to pay. Some wage decisions cover several counties and/or types of construction work (for example, residential and commercial work) and can be lengthy and difficult to read. Contact the contract administrator (HUD Labor Relations field staff or local agency staff) if you have any trouble reading the wage decision or finding the work classification(s) you need.

To make reading lengthy wage decisions easier for you, the contract administrator may prepare a Project Wage Rate Sheet (HUD-4720). This Sheet is a one-page transcript that will show only the classifications and wage rates for a particular project. A blank copy of a Project Wage Rate Sheet is provided for you in the appendix. Also, a fillable version of this form is available on-line at HUDClips (see web address in the Appendix). Contact the contract administrator monitoring your project for assistance with a Project Wage Rate Sheet.

- 
- b. **Posting the wage decision.** If you are the prime contractor, you will be responsible for posting a copy of the wage decision (or the Project Wage Rate Sheet) and a copy of the DOL Davis-Bacon poster titled Employee Rights under the Davis-Bacon Act (Form WH-1321) at the job site in a place that is easily accessible to all of the construction workers employed at the project and where the wage decision and poster won't be destroyed by wind or rain, etc. The Employee Rights under the Davis-Bacon Act poster is available in English and Spanish on-line at HUDClips (see address in the Appendix).

The Employee Rights under the Davis-Bacon Act poster (WH-1321) replaces the Notice to all Employees. The new poster is available in English and Spanish on-line at HUDClips (see address in the Appendix).

## 2-2 **ADDITIONAL "TRADE" CLASSIFICATIONS AND WAGE RATES.**

What if the work classification you need isn't on the wage decision? If the work classification(s) that you need doesn't appear on the wage decision, you will need to request an additional classification and wage rate. This process is usually very simple and you'll want to start the request right away. Basically, you identify the classification you need and recommend a wage rate for DOL to approve for the project. There are a few rules about additional classifications; you'll find these rules in the DOL regulations, Part 5, and in the labor clauses in your contract. The rules are summarized for you here:

- a. **Additional classification rules.** Additional classifications and wage rates can be approved if:
1. The requested classification is used by construction contractors in the area of the project. (The area is usually defined as the county where the project is located).
  2. The work that will be performed by the requested classification is not already performed by another classification that is already on the wage decision. (In other words, if there already is an Electrician classification and wage rate on the wage decision you can't request another Electrician classification and rate.)
  3. The proposed wage rate for the requested classification "fits" with the other wage rates already on the wage decision. (For example, the wage rate proposed for a trade classification such as Electrician must be at least as much as the lowest wage rate for other trade classifications already contained in the wage decision.)  
And,
  4. The workers that will be employed in the added classification (if it is known who the workers are/will be), or the workers' representatives, must agree with the proposed wage rate.

- 
- b. **Making the request.** A request for additional classification and wage rate must be made in writing through the contract administrator. (If the contract administrator is a local agency, the agency will send the request to the HUD Labor Relations staff.) If you are a subcontractor, your request should also go through the prime contractor. All you need to do is identify the work classification that is missing and recommend a wage rate (usually the rate that employer is already paying to the employees performing the work) for that classification. You may also need to describe the work that the new classification will perform.
- c. **HUD review.** The HUD Labor Relations field staff will review the requested classification and wage rate to determine whether the request meets the DOL rules outlined in paragraph 2-2(a), above. If additional information or clarification is needed, the staff will contact the prime contractor (or contract administrator for local agency projects) for more information, etc. If the Labor Relations review finds that the request meets the rules, the staff will give preliminary approval on the request and refer it to the DOL for final approval. The staff will send to you a copy of the preliminary approval/referral letter to the DOL.

If the HUD Labor Relations staff doesn't think the request meets the rules and if agreement can't be reached on the proper classification or wage rate for the work described, the HUD Labor Relations staff will not approve the request. In this case, the staff will send your request to the DOL with an explanation why HUD believes that the request shouldn't be approved. The DOL still has final decision authority. You will receive a copy of the disapproval/referral letter to the DOL.

- d. **DOL decision.** The DOL will respond to HUD Labor Relations in writing about the additional classification and wage rate request. HUD Labor Relations will notify you of the DOL decision in writing. If the DOL approves the request, the prime contractor must post the approval notice on the job site with the wage decision.

If the DOL does not approve the request, you will be notified about what classification and wage rate should be used for the work in question. You will also receive instructions about how to ask for DOL reconsideration if you still want to try to get your recommendation approved.

It's always a good idea to talk to the contract administrator before submitting an additional classification and wage rate request. The contract administrator can offer suggestions and advice that may save you time and increase the likelihood that DOL will approve your request. Usually, the contract administrator can give you an idea about what the DOL will finally decide.



---

## 2-3 **CERTIFIED PAYROLL REPORTS.**

You'll need to submit a weekly certified payroll report (CPR) beginning with the first week that your company works on the project and for every week afterward until your firm has completed its work. It's always a good idea to number the payroll reports beginning with #1 and to clearly mark your last payroll for the project "Final."

- a. **Payroll formats.** The easiest form to use is DOL's WH-347, Payroll. A sample copy of the WH-347 is included in the back of this Guide. You may access a fillable version of the WH-347 on-line at HUDClips (see web address in the Appendix). Also, the contract administrator can provide a few copies of the WH-347 that you can reproduce.

You are not required to use Payroll form WH-347. You are welcome to use any other type of payroll, such as computerized formats, as long as it contains all of the information that is required on the WH-347.

- b. **Payroll certifications.** The weekly payrolls are called certified because each payroll is signed and contains language certifying that the information is true and correct. The payroll certification language is on the reverse side of the WH-347. If you are using another type of payroll format you may attach the certification from the back of the WH-347, or any other format which contains the same certification language on the WH-347 (reverse).

DOL's website has Payroll Instructions and the Payroll form WH-347 in a "fillable" PDF format at this address:  
[www.dol.gov/whd/forms/wh347.pdf](http://www.dol.gov/whd/forms/wh347.pdf)

- c. **"No work" payrolls.** "No work" payrolls may be submitted whenever there is a temporary break in your work on the project, for example, if your firm is not needed on the project right now but you will be returning to the job in a couple of weeks. (See tip box, for "no work" payroll exemption!) However, if you know that your firm will not be working on the project for an extended period of time, you may wish to send a short note to the contract administrator to let them know about the break in work and to give an approximate date when your firm will return to the project. If you number payrolls consecutively or if you send a note, you do not need to send "no work" payrolls.

If you number your payroll reports consecutively, you do not need to submit "no work" payrolls!

- 
- d. **Payroll review and submission.** The prime contractor should review each subcontractor’s payroll reports for compliance prior to submitting the reports to the contract administrator. Remember, the prime contractor is responsible for the full compliance of all subcontractors on the contract and will be held accountable for any wage restitution that may be found due to any laborer or mechanic that is underpaid and for any liquidated damages that may be assessed for overtime violations. All of the payroll reports for any project must be submitted to the contract administrator through the prime contractor.

An alert prime contractor that reviews subcontractor payroll submissions can detect any misunderstandings early, prevent costly underpayments and protect itself from financial loss should underpayments occur.

- e. **Payroll retention.** Every contractor (including every subcontractor) must keep a complete set of their own payrolls and other basic records such as employee addresses and full SSNs, time cards, tax records, evidence of fringe benefit payments, for a Davis-Bacon project for at least 3 years after the project is completed. The prime contractor must keep a complete set of all of the payrolls for every contractor (including subcontractors) for at least 3 years after completion of the project.
- f. **Payroll inspection.** In addition to submitting payrolls to the contract administrator, every contractor (including subcontractors) must make their own copy of the payrolls and other basic records available for review or copying to any authorized representative from HUD or from DOL.

## 2-4 **DAVIS-BACON DEFINITIONS.**

Before we discuss how to complete the weekly payroll forms, we need to review a couple of definitions. These definitions can help you understand what will be required of you:

- a. **Laborer or mechanic.** “Laborers” and “mechanics” mean anyone who is performing construction work on the project, including trade journeymen (carpenters, plumbers, sheet metal workers, etc.), apprentices, and trainees and, for CWHSSA purposes, watchmen and guards. “Laborers” and “mechanics” are the two groups of workers that must be paid not less than Davis-Bacon wage rates.
1. **Working foremen.** Foremen or supervisors that regularly spend more than 20% of their time performing construction work and do not meet the exclusions in paragraph 2 below are covered “laborers” and “mechanics” for labor standards purposes for the time spent performing construction work.
  2. **Exclusions.** People whose duties are primarily administrative, executive or clerical are not laborers or mechanics. Examples include superintendents, office staff, timekeepers, messengers, etc. (Contact the contract administrator if you have any questions about whether a particular employee is excluded.)

- 
- b. **Employee.** Every person who performs the work of a laborer or mechanic is “employed” regardless of any contractual relationship which may be alleged to exist between a contractor or subcontractor and such person. This means that even if there is a contract between a contractor and a worker, the contractor must make sure that the worker is paid at least as much as the wage rate on the wage decision for the classification of work they perform. Note that there are no exceptions to the prevailing wage requirements for relatives or for self-employed laborers and mechanics.

For more information about working subcontractors, ask the contract administrator or your HUD Labor Relations Field Staff for a copy of Labor Relations Letter LR-96-01, Labor standards compliance requirements for self-employed laborers and mechanics. Labor Relations Letters and other helpful Labor Relations publications are available at HUD’s Labor Relations web site (see the list of web site addresses in the Appendix).

- c. **Apprentices and trainees.** The only workers who can be paid less than the wage rate on the wage decision for their work classification are “apprentices” and “trainees” registered in approved apprenticeship or training programs. Approved programs are those which have been registered with the DOL or a DOL-recognized State Apprenticeship Council (SAC). Apprentices and trainees are paid wage rates in accordance with the wage schedule in the approved program.

Most often, the apprentice/trainee wage rate is expressed as a series of percentages tied to the amount of time spent in the program. For example, 0-6 months: 65%; 6 months - 1 year: 70%; etc. The percentage is applied to the journeyman’s wage rate. On Davis-Bacon projects, the percentage must be applied to the journeyman’s wage rate on the applicable wage decision for that craft.

1. **Probationary apprentice.** A “probationary apprentice” can be paid as an apprentice (less than the rate on the wage decision) if the DOL or SAC has certified that the person is eligible for probationary employment as an apprentice.
2. **Pre-apprentice.** A “pre-apprentice”, that is, someone who is not registered in a program and who hasn’t been DOL- or SAC-certified for probationary apprenticeship is not considered to be an “apprentice” and must be paid the full journeyman’s rate on the wage decision for the classification of work they perform.
3. **Ratio of apprentices and trainees to journeymen.** The maximum number of apprentices or trainees that you can use on the job site cannot exceed the ratio of apprentices or trainees to journeymen allowed in the approved program.

- 
- d. **Prevailing wages or wage rates.** Prevailing wage rates are the wage rates listed on the wage decision for the project. The wage decision will list a minimum basic hourly rate of pay for each work classification. Some wage decisions include fringe benefits which are usually listed as an hourly fringe rate. If the wage decision includes a fringe benefit rate for a classification, you will need to add the fringe benefit rate to the basic hourly rate unless you provide bona fide fringe benefits for your employees.
1. **Piece-work.** Some employees are hired on a piece-work basis, that is, the employee's earnings are determined by a factor of work produced. For example, a Drywall Hanger's earnings may be calculated based upon the square feet of sheetrock actually hung, a Painter's earnings may be based upon the number of units painted. Employers may calculate weekly earnings based upon piece rates provided the weekly earnings are sufficient to satisfy the wage rate requirement based upon actual hours, including any overtime, worked. Accurate time records must be maintained for any piece-work employees. If the weekly piece rate earnings are not sufficient, the employer must recompute weekly earnings based upon the actual hours worked and the rate on the wage decision for the work classification(s) involved.
- e. **Fringe benefits** Fringe benefits can include health insurance premiums, retirement contributions, life insurance, vacation and other paid leave as well as some contributions to training funds. Fringe benefits do not include employer payments or contributions required by other Federal, State or local laws, such as the employer's contribution to Social Security or some disability insurance payments.

Note that the total hourly wage rate paid to any laborer or mechanic (basic wage or basic wage plus fringe benefits) may be no less than the total wage rate (basic wage or basic wage plus fringe benefits) on the wage decision for their craft. If the value of the fringe benefit(s) you provide is less than the fringe benefit rate on the wage decision, you will need to add the balance of the wage decision fringe benefit rate to the basic rate paid to the employee. For example, if the wage decision requires \$10/hour basic rate plus \$5/hour fringe benefits, you must pay no less than that total (\$15/hour) in the basic rate or basic rate plus whatever fringe benefit you may provide. You can meet this obligation in several ways: you could pay the base wage and fringe benefits as stated in the wage decision, or you could pay \$15 in base wage with no fringe benefits, or you could pay \$12 basic plus \$3 fringe benefits. You can also off-set the amount of the base wage if you pay more in fringe benefits such as by paying or \$9 basic plus \$6 fringe benefits; as long as you meet the total amount. The amount of the base wage that you may off-set with fringe benefits is limited by certain IRS and FLSA requirements.

- f. **Overtime.** Overtime hours are defined as all hours worked on the contract in excess of 40 hours in any work week. Overtime hours must be paid at no less than one and one-half times the regular rate of basic pay plus the straight-time rate of any required fringe benefits.

- 
- g. **Deductions.** You may make payroll deductions as permitted by DOL Regulations 29 CFR Part 3. These regulations prohibit the employer from requiring employees to “kick-back” (i.e., give up) any of their earnings. Allowable deductions which do not require prior DOL permission include employee obligations for income taxes, Social Security payments, insurance premiums, retirement, savings accounts, and any other legally-permissible deduction authorized by the employee. Deductions may also be made for payments on judgments and other financial obligations legally imposed against the employee.

Referring, again, to our example above where the wage decision requiring a \$15 total wage obligation (\$10 basic wage plus \$5 fringe benefits) was met by paying \$9 base wage plus \$6 fringe benefits: Note that overtime rates must be based on one and one-half times the basic rate as stated on the wage decision. In the above example, the employer must pay for overtime: \$15/hr (\$9 basic + \$6 fringe) plus \$5 (one-half of \$10, the wage decision basic rate) for a total of \$20 per hour.

- h. **Proper designation of trade.** You must select a work classification on the wage decision for each worker based on the actual type of work he/she performed and you must pay each worker no less than the wage rate on the wage decision for that classification regardless of their level of skill. In other words, if someone is performing carpentry work on the project, they must be paid no less than the wage rate on the wage decision for Carpenters even if they aren’t considered by you to be fully trained as a Carpenter. Remember, the only people who can be paid less than the rate for their craft are apprentices and trainees registered in approved programs.
1. **Split-classification.** If you have employees that perform work in more than one trade during a work week, you can pay the wage rates specified for each classification in which work was performed only if you maintain accurate time records showing the amount of time spent in each classification of work. If you do not maintain accurate time records, you must pay these employees the highest wage rate of all of the classifications of work performed.
- i. **Site of work.** The “site of work” is where the Davis-Bacon wage rates apply. Usually, this means the boundaries of the project. “Site of work” can also include other adjacent or virtually adjacent property used by a contractor or subcontractor in the construction of the project, like a fabrication site that is dedicated exclusively, or nearly so, to the project.

---

## SECTION II - REPORTING REQUIREMENTS

### 2-5 COMPLETING A PAYROLL REPORT.

What information has to be reported on the payroll form? The weekly payroll form doesn't ask for any information that you don't already need to keep for wage payment and tax purposes. For example, you need to know each employee's name; his or her work classification (who is working for you and what do they do?), the hours worked during the week, his or her rate of pay, the gross amount earned (how much did they earn?), the amounts of any deductions for taxes, etc., and the net amount paid (how much should the paycheck be made out for?). No more information than you need to know in order to manage your work crew and make certain they are paid properly. And, certainly, no more information than you need to keep for IRS, Social Security and other tax and employment purposes.

For many contractors, the Weekly Certified Payroll is the only Davis-Bacon paperwork you need to submit!

You are required to submit certified payrolls to illustrate and document that you have complied with the prevailing wage requirements. The purpose of the contract administrator's review of your payrolls is to verify your compliance. Clearer and complete payroll reports will permit the contract administrator to complete reviews of your payroll reports quickly.

- a. **Project and contractor/subcontractor information.** Each payroll must identify the contractor or subcontractor's name and address, the project name and number, and the week ending date. Indicate the week dates in the spaces provided. Numbering payrolls is optional but strongly recommended.
- b. **Employee information.** Effective January 18, 2009, payrolls shall not report employee addresses or full Social Security Numbers (SSNs). Instead, the first payroll on which each employee appears shall include the employee's name and an individually identifying number, usually the last 4 digits of the employee's SSN. Afterward, the identifying number does not need to be reported unless it is necessary to distinguish between employees, e.g., if two employees have the same name.

Employers (prime contractors and subcontractors) must maintain the current address and full SSN for each employee and must provide this information upon request to the contracting agency or other authorized representative responsible for federal labor standards compliance monitoring. Prime contractors may require a subcontractor(s) to provide this information for the prime contractor's records. DOL has modified form WH-347, Payroll, to accommodate these reporting requirements.

- c. **Work classification.** Each employee must be classified in accordance with the wage decision based on the type of work they actually perform.

- 
1. **Apprentices or trainees.** The first payroll on which any apprentice or trainee appears must be accompanied by a copy of that apprentice's or trainee's registration in a registered or approved program. A copy of the portions of the registered or approved program pertaining to the wage rates and ratios shall also accompany the first payroll on which the first apprentice or trainee appears.
  2. **Split classifications.** For an employee that worked in a split classification, make a separate entry for each classification of work performed distributing the hours of work to each classification, accordingly, and reflecting the rate of pay and gross earnings for each classification. Deductions and net pay may be based upon the total gross amount earned for all classifications.
- d. **Hours worked.** The payroll should show ONLY the regular and overtime hours worked on this project. Show both the daily and total weekly hours for each employee. If an employee performs work at job sites other than the project for which the payroll is prepared, those "other job" hours should not be reported on the payroll. In these cases, you should list the employee's name, classification, hours for this project only, the rate of pay and gross earnings for this project, and the gross earned for all projects. Deductions and net pay may be based upon the employee's total earnings (for all projects) for the week.
- e. **Rate of pay.** Show the basic hourly rate of pay for each employee for this project. If the wage decision includes a fringe benefit and you do not participate in approved fringe benefit programs, add the fringe benefit rate to the basic hourly rate of pay. Also list the overtime rate if overtime hours were worked.
1. **Piece-work.** For any piece-work employees, the employer must compute an effective hourly rate for each employee each week based upon the employee's piece-work earnings for that week. To compute the effective hourly rate, divide the piece-work earnings by the total number of hours worked, including consideration for any overtime hours.

The effective hourly rate must be reflected on the certified payroll and this hourly rate may be no less than the wage rate (including fringe benefits, if any) on the wage decision for the classification of work performed. It does not matter that the effective hourly rate changes from week-to-week, only that the rate is no less than the rate on the wage decision for the classification of work performed.

Remember, the overtime rate is computed at one and one-half times the basic rate of pay plus any fringe benefits. For example, if the wage decision requires \$10/hour basic plus \$5/hour fringe benefits, the overtime rate would be:  $(\$10 \times 1 \frac{1}{2}) + \$5 = \$20/\text{hour}$ .

- f. **Gross wages earned.** Show the gross amount of wages earned for work performed on this project. Note: For employees with work hours and earnings on other projects, you may show gross wages for this project over gross earnings all projects (for example, \$425.40/\$764.85) and base deductions and net pay on the "all projects" earnings.

- 
- g. **Deductions.** Show the amounts of any deductions from the gross earnings. “Other” deductions should be identified (for example, Savings Account or Loan Repayment). Any voluntary deduction (that is, not required by law or by an order of a proper authority) must be authorized in writing by the employee or provided for in a collective bargaining (union) agreement. A short note signed by the employee is all that is needed and should accompany the first payroll on which the other deduction appears.

Only one employee authorization is needed for recurring (e.g., weekly) other deductions. Written employee authorization is not required for income tax and Social Security deductions.

- h. **Net pay.** Show the net amount of wages paid.
- i. **Statement of compliance.** The Statement of Compliance is the certification. It is located on the reverse side of a standard payroll form (WH-347). Be sure to complete the identifying information at the top, particularly if you are attaching the Statement of Compliance to an alternate payroll form such as a computer payroll. Also, you must check either 4(a) or 4(b) if the wage decision contains a fringe benefit. Checking 4(a) indicates that you are paying required fringe benefits to approved plans or programs; and 4(b) indicates that you are paying any required fringe benefit amounts directly to the employee by adding the fringe benefit rate to the basic hourly rate of pay. If you are paying a portion of the required fringe benefit to programs and the balance directly to the employee, explain those differences in box 4(c).

Only one Statement of Compliance is required for each employer’s weekly payroll no matter how many pages are needed to report the employee data.

- j. **Signature.** Make sure the payroll is signed with an original signature in ink. The payroll must be signed by a principal of the firm (owner or officer such as the president, treasurer or payroll administrator) or by an authorized agent (a person authorized by a principal in writing to sign the payroll reports). Signature authorization (for persons other than a principal) should be submitted with the first payroll signed by such an agent. Signatures in pencil; signature stamps; xerox, pdf and other facsimiles are not acceptable.



---

## SECTION III - PAYROLL REVIEWS AND CORRECTIONS

### 2-6 COMPLIANCE REVIEWS.

The contract administrator or other inspector may visit the project site and interview some of the workers concerning their employment on the project. The DOL may also independently conduct its own reviews (see 1-5). In addition, the contract administrator will periodically review payrolls and related submissions, comparing the interview information to the payrolls, to ensure that the labor standards requirements have been met. You will be notified by the contract administrator if these reviews find any discrepancies or errors. You will be given instructions about what steps must be taken to correct any problems.

- a. **On-site interviews.** Every employer (contractor, subcontractor, etc.) must make their employees available for interview at the job site with the contract administrator or other agency representative, or HUD or DOL representative. The interviews are confidential and the employee will be asked about the kind of work they perform and their rate of pay. Every effort will be made to ensure that these interviews cause as little disruption as possible to the on-going work. The interviewer will record the interview information, usually on a form HUD-11, Record of Employee Interview, and forward the interviews to the contract administrator.
- b. **Project payroll reviews.** The contract administrator will compare the information on the interview forms to the corresponding payrolls to ensure that the workers are properly listed on the payrolls for the days and hours worked on the job site, work classification and rate of pay. The contract administrator will also review the payroll submissions to make certain that the payrolls are complete and signed; that employees are paid no less than the wage rate for the work classification shown; apprentice and trainee certifications are submitted (where needed); employee or other authorizations for other deductions are submitted (where needed); etc.

### 2-7 TYPICAL PAYROLL ERRORS AND REQUIRED CORRECTIONS.

The following paragraphs describe common payroll errors and the corrective steps you must take.

- a. **Inadequate payroll information.** If an alternate payroll format used by an employer (such as some computer payrolls) is inadequate, e.g., does not contain all of the necessary information that would be on the optional form WH-347, the employer will be asked to resubmit the payrolls on an acceptable form.
- b. **Missing identification numbers.** If the first payroll on which an employee appears does not contain the employee's individually identifying number, the employer will be asked to supply the missing information. This information can be reported on the next payroll submitted by the employer if the employer is still working on the project. Otherwise, the employer will be asked to submit a correction certified payroll.

- 
- c. **Incomplete payrolls.** If the information on the payroll is not complete, for example, if work classifications or rates of pay are missing, the employer will be asked to send a correction certified payroll.
- d. **Classifications.** If the payrolls show work classifications that do not appear on the wage decision, the employer will be asked to reclassify the employees in accordance with the wage decision or the employer may request an additional classification and wage rate (see 2-2). If reclassification results in underpayment (i.e., the wage rate reported on the payroll is less than the rate required for the new classification), the employer will be asked to pay wage restitution to all affected reclassified employees. (see 2-8 for instructions about wage restitution.)
- e. **Wage rates.** If the wage rates on the payroll are less than the wage rates on the wage decision for the work classifications reported, the employer will be asked to pay wage restitution to all affected employees.
- f. **Apprentices and trainees.** If a copy of the employee's registration or the approved program ratio and wage schedule are not submitted with the first payroll on which an apprentice or trainee appears, the employer will be asked to submit a copy of each apprentice's or trainee's registration and/or the approved program ratio and wage schedule. If the ratio of apprentices or trainees to journeymen on the payroll is greater than the ratio in the approved program, the employer will be asked to pay wage restitution to any excess apprentices or trainees. Also, any apprentice or trainee that is not registered in an approved program must receive the journeyman's wage rate for the classification of work they performed.
- g. **Overtime.** If the employees did not receive at least time and one-half for any overtime hours worked on the project, the following will occur:
1. If the project is subject to CWHSSA overtime requirements, the employer will be asked to pay wage restitution for all overtime hours worked on the project. The employer may also be liable to the United States for liquidated damages computed at \$10 per day per violation. Or,
  2. If the project is not subject to CWHSSA, the employer will be notified of the possible FLSA overtime violations. Also, the contract administrator may refer the matter to the DOL for further review.
- h. **Computations.** If the payroll computations (hours worked times rate of pay) or extensions (deductions, net pay) show frequent errors, the employer will be asked to take greater care. Wage restitution may be required if underpayments resulted from the errors.
- i. **Deductions.** If there are any "Other" deductions that are not identified, or if employee authorization isn't provided, or if there is any unusual (very high, or large number) deduction activity, the employer will be asked to identify the deductions, provide employee authorization or explain unusual deductions, as necessary.

---

HUD does not enforce or attempt to provide advice on employer obligations to make deductions from employee earnings for taxes or Social Security. However, HUD may refer to the IRS or other responsible agency copies of certified payroll reports that show wages paid in gross amounts (i.e., without tax deduction) for its review and appropriate action.

- j. **Fringe benefits.** If the wage decision contains fringe benefits but the payroll does not indicate how fringe benefits were paid [neither 4(a) nor 4(b) is marked on the Statement of Compliance], the employer may be asked to submit correction certified payrolls and will be required to pay wage restitution if underpayments occurred. However, if the basic hourly rates for the employees are at least as much as the total wage rate on the wage decision (basic hourly rate plus the fringe benefit rate), no correction is necessary.
- k. **Signature.** If the payroll Statement of Compliance is not signed or is missing, the employer will be asked to submit a signed Statement of Compliance for each payroll affected. If the Statement of Compliance is signed by a person who is not a principle of the firm and that person has not been authorized by principle to sign, the employer will be asked to provide an authorization or to resubmit the Statement(s) of Compliance bearing the signature of a principle or other authorized signatory.
- l. **On-site interview comparisons.** If the comparison of on-site interviews to the payrolls indicates any discrepancies (for example, the employee does not appear on the payroll for the date of the interview), the employer will be asked to submit a correction certified payroll report.
- m. **Correction certified payroll.** Any and all changes to data on a submitted payroll report must be reported on a certified correction payroll. In no case will a payroll report be returned to the prime contractor or employer for revision.

## 2-8 **RESTITUTION FOR UNDERPAYMENT OF WAGES.**

Where underpayments of wages have occurred, the employer will be required to pay wage restitution to the affected employees. Wage restitution must be paid promptly in the full amounts due, less permissible and authorized deductions. All wages paid to laborers and mechanics for work performed on the project, including wage restitution, must be reported on a certified payroll report.

- a. **Notification** to the Employer/Prime contractor. The contract administrator will notify the employer and/or prime contractor in writing of any underpayments that are found during payroll or other reviews. The contract administrator will describe the underpayments and provide instructions for computing and documenting the restitution to be paid. The employer/prime contractor is allowed 30 days to correct the underpayments. Note that the prime contractor is responsible to the contract administrator for ensuring that restitution is paid. If the employer is a subcontractor, the subcontractor will usually make the computations and restitution payments and furnish the required documentation through the prime contractor.

---

The contract administrator may communicate directly with a subcontractor when the underpayments are plainly evident and the subcontractor is cooperative. It is best to work through the prime contractor when the issues are complex, when there are significant underpayments and/or the subcontractor is not cooperative. In all cases, the subcontractor must ensure that the prime contractor receives a copy of the required corrective documentation.

- b. **Computing wage restitution.** Wage restitution is simply the difference between the wage rate paid to each affected employee and the wage rate required on the wage decision for all hours worked where underpayments occurred. The difference in the wage rates is called the adjustment rate. The adjustment rate times the number of hours involved equals the gross amount of restitution due. You may also compute wage restitution by calculating the total amount of Davis-Bacon wages earned and subtracting the total amount of wages paid. The difference is the amount of back wages due.
- c. **Correction certified payrolls.** The employer will be required to report the restitution paid on a correction certified payroll. The correction payroll will reflect the period of time for which restitution is due (for example, Payrolls #1 through #6; or a beginning date and ending date). The correction payroll will list each employee to whom restitution is due and their work classification; the total number of work hours involved (daily hours are usually not applicable for wage restitution); the adjustment wage rate (the difference between the required wage rate and the wage rate paid); the gross amount of restitution due; deductions and the net amount actually paid. A properly signed Statement of Compliance must accompany the correction payroll.

HUD no longer requires the signature of the employee on the correction payroll to evidence employee receipt of restitution payment. In addition, except in the most extraordinary cases, HUD no longer requires employers to submit copies of restitution checks (certified, cashiers, canceled or other), or employee-signed receipts or waivers.

- d. **Review of correction CPR.** The contract administrator will review the correction certified payroll to ensure that full restitution was paid. The prime contractor shall be notified in writing of any discrepancies and will be required to make additional payments, if needed, documented on a correction certified payroll within 30 days.
- e. **Unfound workers.** Sometimes, wage restitution cannot be paid to an affected employee because, for example, the employee has moved and can't be located. After wage restitution has been paid to all of the workers who could be located, the employer must submit a list of any workers who could not be found and paid (i.e., unfound workers) providing their names, Social Security Numbers, last known addresses and the gross amount due. In such cases, at the end of the project the prime contractor will be required

---

to place in a deposit or escrow account an amount equal to the total gross amount of restitution that could not be paid because the employee(s) could not be located. The contract administrator will continue attempts to locate the unfound workers for 3 years after the completion of the project. After 3 years, any amount remaining in the account for unfound workers will be credited and/or forwarded by the contract administrator to HUD.

---

## CHAPTER 3    LABOR STANDARDS DISPUTES, ADMINISTRATIVE REVIEWS, WITHHOLDING, DEPOSITS AND ESCROW ACCOUNTS, AND SANCTIONS

### WHAT HAPPENS WHEN THINGS GO WRONG?

#### **3-1    INTRODUCTION.**

Even in the best of circumstances, things can go wrong. In a Davis-Bacon context, “things going wrong” usually means there’s a difference of opinion or a dispute about whether and to what extent underpayments have occurred. These disputes are usually between the contract administrator and one or more employers (the prime contractor and/or a subcontractor). The dispute may involve something simple such as an additional classification request that is pending before the DOL; or something as significant as investigative findings following a complaint of underpayment. This chapter discusses some of what you may expect and what you can do to make your views known and to lessen any delays in resolving the problem or issue.

#### **3-2    ADMINISTRATIVE REVIEW ON LABOR STANDARDS DISPUTES.**

As mentioned in the Introduction above, a dispute about labor standards and compliance can arise for a number of reasons. The labor standards clauses in your contract and DOL regulations provide for administrative review of issues where there is a difference of views between the contract administrator and any employer. The most common circumstances include:

- a. **Additional classifications and wage rates.** Additional classification and wage rate requests are sometimes denied by the DOL. An employer that is dissatisfied with the denial can request reconsideration by the DOL Wage and Hour Administrator. The employer may continue to pay the wage rate, as requested, until a final decision is rendered on the matter. When the final decision is known, the employer will be required to pay any additional wages that may be necessary to satisfy the wage rate that is established.
  1. **Reconsideration.** The DOL normally identifies the reasons for denial in its response to the request. Any interested person (for example, the contract administrator, employer, representatives of the employees) may request reconsideration of the decision on the additional classification request. The request for reconsideration must be made in writing and must thoroughly address the denial reasons identified by the DOL. Employer requests for reconsideration should be made through the contract administrator but may be made directly to the DOL. (See 2-2(d), and also DOL Regulations 29 CFR 1.8.) All requests initiated by or made through the contract administrator or HUD must be submitted through the HUD Headquarters Office of Labor Relations.

---

2. **Administrative Review Board.** Any interested party may request a review of the Administrator's decision on reconsideration by the DOL's Administrative Review Board. DOL regulations 29 CFR Part 7 explain the procedures for such reviews. (See also 29 CFR 1.9.)

b. **Findings of underpayment.** Compliance reviews and other follow-up enforcement actions may result in findings of underpayment. The primary goal in every case and at every step in this process is to reach agreements about who may have been underpaid and how much wage restitution may be due and, of course, to promptly deliver restitution to any underpaid workers. The contract administrator will usually work informally with you to reach such agreements. You will have an opportunity to provide additional information to the contract administrator that may explain apparent inconsistencies and/or resolve the discrepancies.

If informal exchanges do not result in agreement, the final determination and schedule of back wages due will be presented to you in writing and you will be permitted 30 days in which to correct the underpayment(s) or to request a hearing on the matter before the DOL. The request for hearing must be made in writing through the contract administrator and must explain what findings are in dispute and the reasons. In such cases, HUD is required to submit a report to DOL for review and further consideration. All requests for DOL hearing must be submitted through the HUD Headquarters Office of Labor Relations.

1. **DOL review.** The DOL will review the contract administrator's report and the arguments against the findings presented in the hearing request. The DOL may affirm or modify the findings based upon the materials presented. You will be notified in writing by the DOL of the results of its review. If DOL concludes that violations have occurred, you will be given an opportunity to correct any underpayments or to request a hearing before a DOL Administrative Law Judge (ALJ). (See DOL Regulations 29 CFR 5.11 (b) and 29 CFR Part 6, Rules of Practice for Administrative Proceedings.)

2. **Administrative Review Board.** Contractors and/or subcontractors may request a review by the Administrative Review Board of the decision(s) rendered by the DOL ALJ in the administrative hearing process. See DOL regulations 29 CFR Part 7 for more information about this proceeding.

### **3-3 WITHHOLDING.**

The contract administrator shall cause withholding from payments due to the prime contractor to ensure the payment of wages which are believed to be due and unpaid, for example, if wage underpayments or other violations are not corrected within 30 days after written notification to the prime contractor. DOL may also direct the withholding of contract payments for alleged wage underpayments. Withholding is considered to be serious and is not taken unless warranted. If withholding is deemed necessary, you will be notified in writing. Only the amounts needed to meet the contractor's (and/or subcontractors') liability shall be withheld.

---

### 3-4 **DEPOSITS AND ESCROWS.**

In every case, we attempt to complete compliance actions and resolve any disputes before the project is completed and final payments are made. Sometimes, corrective actions or disputes continue after completion and provisions must be made to ensure that funds are available to pay any wage restitution that is ultimately found due. In these cases, we allow projects to proceed to final closing and final payments provided the prime contractor deposits an amount equal to the potential liability for wage restitution and liquidated damages, if necessary, in a special account. The deposit or escrow account is controlled by the contract administrator. When a final decision is rendered, the contract administrator makes disbursements from the account in accordance with the decision. Deposit/escrow accounts are established for one or more of the following reasons:

Remember, the prime contractor is responsible and will be held liable for any wage restitution that is due to any worker employed in the construction of the project, including workers employed by subcontractors and any lower-tier subcontractors. See 1-4, Responsibility of the Principal Contractor, and 2-8, Restitution for Underpayment of Wages.

- a. **Where the parties have agreed to amounts of wage restitution that are due** but the employer hasn't furnished evidence yet that all of the underpaid workers have received their back wages, e.g., some of the workers have moved and could not be located. The amount of the deposit is equal to the total gross amount of restitution due to workers lacking payment evidence. As these workers are paid and proper documentation is provided to the contract administrator, amounts corresponding to the documented payments are returned to the depositor. Amounts for any workers who cannot be located are held in the deposit/escrow account for three years and disposed as described in 2-8(f) of this Guide.
- b. **Where underpayments are suspected or alleged and an investigation has not yet been completed.** The deposit is equal to the amount of wage restitution and any liquidated damages, if applicable, that are estimated to be due. If the final determination of wages due is less than the amount estimated and placed in the escrow account, the escrow will be reduced to the final amount and the difference will be returned to the depositor.

If the parties agree to the investigative findings, the amounts due to the workers will be paid by the employer. As these workers are paid and proper documentation is provided to the contract administrator, the gross amounts corresponding to the documented payments are returned to the depositor.

1. If the employer is unable to make the payments to the workers, e.g., lacks the funds necessary, the contract administrator may make disbursements directly to the workers in the net amounts calculated by the employer. The amounts withheld from the workers for tax deduction will be returned to the employer as payments to workers are made. The employer shall be responsible for reporting and transmitting withholdings to the appropriate agencies.



- 
2. If the employer is not cooperating in the resolution, the contract administrator shall make disbursements to the workers in accordance with the schedule of wages due. Amounts for unfound workers will be retained as described above (See 2-8(f) and 3-4(a)).

If the parties do not agree and an administrative hearing is requested, the escrow will be maintained as explained in 3-4(c), below.

Remember, if you have any questions or need assistance concerning labor standards requirements help is always available. Contact the contract administrator for the project you're working on or the HUD Field Labor Relations staff in your area.

- c. **Where the parties are waiting for the outcome of an administrative hearing** that has been or will be requested contesting a final determination of wages due. The deposit shall be equal to the amount of wage restitution and liquidated damages, if applicable, that have been determined due. Once a final decision is rendered, disbursements from the escrow account are made in accordance with the decision.

### **3-5 ADMINISTRATIVE SANCTIONS.**

Contractors and/or subcontractors that violate the labor standards provisions may face administrative sanctions imposed by HUD and/or DOL.

- a. **DOL debarment.** Contractors and/or subcontractors that are found by the Secretary of Labor to be in aggravated or willful violation of the labor standards provisions of the Davis-Bacon and Related Acts (DBRA) will be ineligible (debarred) to participate in any DBRA or Davis-Bacon Act contracts for up to 3 years. Debarment includes the contractor or subcontractor and any firm, corporation, partnership or association in which the contractor or subcontractor has a substantial interest. Debarment proceedings can be recommended by the contract administrator or can be initiated by the DOL. Debarment proceedings are described in DOL regulations 29 CFR 5.12.
- b. **HUD sanctions.** HUD sanctions may include Limited Denials of Participation (LDPs), debarments and suspensions.
  1. **Limited Denial of Participation.** HUD may issue to the employer a limited denial of participation (LDP) which prohibits the employer from further participation in HUD programs for a period up to one year. The LDP is usually effective for the HUD program in which the violation occurred and for the geographic jurisdiction of the issuing HUD Office. HUD regulations concerning LDP's are found at 24 CFR 24.700-24.714.

- 
2. **Debarment and suspensions.** In certain circumstances, HUD may initiate its own debarment or suspension proceedings against a contractor and/or subcontractor in connection with improper actions regarding Davis-Bacon obligations. For example, HUD may initiate debarment where a contractor has been convicted for making false statements (such as false statements on certified payrolls or other prevailing wage certifications) or may initiate suspension where a contractor has been indicted for making false statements. HUD regulations concerning debarment and suspension are found at 24 CFR Part 24.

### **3-6 FALSIFICATION OF CERTIFIED PAYROLL REPORTS.**

Contractors and/or subcontractors that are found to have willfully falsified payroll reports (Statements of Compliance), including correction certified payroll reports, may be subject to civil or criminal prosecution. Penalties may be imposed of \$1,000 and/or one year in prison for each false statement (see Section 1001 of Title 18 and Section 231 of Title 31 of the United States Code).

Remember, if you have any questions or need assistance concerning labor standards requirements help is always available. Contact the contract administrator for the project you're working on or the HUD Field Labor Relations staff in your area.

---

## ACRONYMS AND SYMBOLS

CDBG -	Community Development Block Grant
CFR -	Code of Federal Regulations
CPR -	Certified Payroll Report
CWHSSA -	Contract Work Hours and Safety Standards Act
DBA -	Davis-Bacon Act
DBRA -	Davis-Bacon and Related Acts
DOL -	Department of Labor
FHA -	Federal Housing Administration
FLSA -	Fair Labor Standards Act
HUD -	Housing and Urban Development (Department of)
IHA -	Indian Housing Authority
LCA -	Local Contracting Agency
LDP -	Limited Denial of Participation
O/T -	Overtime
PHA -	Public Housing Agency
S/T -	Straight-time
SAC -	State Apprenticeship Council/Agency
TDHE -	Tribally-Designated Housing Entity
§ -	Section
¶ -	Paragraph

---

## DAVIS-BACON - RELATED WEB SITES\*

HUD Office of Labor Relations:  
[www.hud.gov/offices/olr](http://www.hud.gov/offices/olr)

HUD Regulations:  
<http://www.gpo.gov/fdsys/browse/collectionCfr.action?collectionCode=CFR>

HUDClips (HUD Forms and Publications):  
[www.hud.gov/offices/adm/hudclips/index.cfm](http://www.hud.gov/offices/adm/hudclips/index.cfm)

DOL Davis-Bacon and Related Acts Homepage:  
<http://www.dol.gov/whd/contracts/dbra.htm>

DOL Regulations:  
<http://www.gpo.gov/fdsys/browse/collectionCfr.action?collectionCode=CFR>

Davis-Bacon Wage Decisions:  
[www.wdol.gov](http://www.wdol.gov)

DOL Forms:  
[www.dol.gov/whd/programs/dbra/forms.htm](http://www.dol.gov/whd/programs/dbra/forms.htm)

**\*Web addresses active as of January 2012**

<b>Project Wage Rate Sheet</b>	U.S. Department of Housing and Urban Development Office of Labor Relations	
--------------------------------	---	--

Project Name:	Wage Decision Number/Modification Number:
---------------	---

Project Number:	Project County:
-----------------	-----------------

Work Classification	Basic Hourly Rate (BHR)	Fringe Benefits	Total Hourly Wage Rate	Laborers Fringe Benefits		\$
				Group #	BHR	
Bricklayers			\$	Group #	BHR	Total Wage
Carpenters			\$			\$
Cement Masons			\$			\$
Drywall Hangers			\$			\$
Electricians			\$			\$
Iron Workers			\$			\$
Painters			\$	Operators Fringe Benefits:		\$
Plumbers			\$	Group #	BHR	Total Wage
Roofers			\$			\$
Sheet Metal Workers			\$			\$
Soft Floor Workers			\$			\$
Tapers			\$			\$
Tile Setters			\$	Truck Drivers Fringe Benefits:		\$
<b>Other Classifications</b>				<b>Group #</b>	<b>BHR</b>	<b>Total Wage</b>
			\$			
			\$			
			\$			

**Additional Classifications (HUD Form 4230-A)**

Work Classification	Basic Hourly Rate (BHR)	Fringe Benefits	Total Hourly Wage Rate	Date of HUD Submission to DOL	Date of DOL Approval
			\$		
			\$		
			\$		



**U.S. Department of Labor**  
Wage and Hour Division

**PAYROLL**  
**(For Contractor's Optional Use; See Instructions at [www.dol.gov/whd/forms/wh347instr.htm](http://www.dol.gov/whd/forms/wh347instr.htm))**

Rev. Dec. 2008

OMB No.: 1215-0149  
Expires: 12/31/2011

Persons are not required to respond to the collection of information unless it displays a currently valid OMB control number.

NAME OF CONTRACTOR  OR SUBCONTRACTOR  ADDRESS PROJECT OR CONTRACT NO.

PAYROLL NO. PROJECT AND LOCATION

(1) NAME AND INDIVIDUAL IDENTIFYING NUMBER (e.g., LAST FOUR DIGITS OF SOCIAL SECURITY NUMBER) OF WORKER	(2) NO OF WITHOLDING EXEMPTIONS	(3) WORK CLASSIFICATION	(4) DAY AND DATE							(5) TOTAL HOURS	(6) RATE OF PAY	(7) GROSS AMOUNT EARNED	(8) DEDUCTIONS			(9) NET WAGES PAID FOR WEEK
			MON	TUE	WED	THUR	FRI	SAT	SUN				FICA	WITH- HOLDING TAX	OTHER	

While completion of Form WH-347 is optional, it is mandatory for covered contractors and subcontractors performing work on Federally financed or assisted construction contracts to respond to the information collection contained in 29 C.F.R. §§ 3.3, 5.5(a). The Copeland Act (40 U.S.C. § 3145) contractors and subcontractors performing work on Federally financed or assisted construction contracts to "furnish weekly a statement with respect to the wages paid each employee during the preceding week." U.S. Department of Labor (DOL) regulations at 29 C.F.R. § 5.5(a)(3)(i) require contractors to submit weekly a copy of all payrolls to the Federal agency contracting for financing the construction project, accompanied by a signed "Statement of Compliance" indicating that the payrolls are correct and complete and that each laborer or mechanic has been paid not less than the proper Davis-Bacon prevailing wage rate for the work performed. DOL and federal contracting agencies receiving this information review the information to determine if employees have received legally required wages and fringe benefits.

**Public Burden Statement**

We estimate that it will take an average of 55 minutes to complete this collection, including time for reviewing instructions, searching existing data sources, gathering and maintaining the data needed, and completing and reviewing the collection of information. If you have any comments regarding these estimates or any other aspect of this collection, including suggestions for reducing this burden, send them to the Administrator, Wage and Hour Division, U.S. Department of Labor, Room S3502, 200 Constitution Avenue, N.W., Washington, D.C. 20210

Date \_\_\_\_\_

I, \_\_\_\_\_ (Name of Signatory Party) \_\_\_\_\_ (Title)

do hereby state:

(1) That I pay or supervise the payment of the persons employed by

\_\_\_\_\_ (Contractor or Subcontractor) \_\_\_\_\_ on the \_\_\_\_\_ (Building or Work) \_\_\_\_\_; that during the payroll period commencing on the \_\_\_\_\_ day of \_\_\_\_\_, and ending the \_\_\_\_\_ day of \_\_\_\_\_

all persons employed on said project have been paid the full weekly wages earned, that no rebates have been or will be made either directly or indirectly to or on behalf of said \_\_\_\_\_ (Contractor or Subcontractor) \_\_\_\_\_ from the full

weekly wages earned by any person and that no deductions have been made either directly or indirectly from the full wages earned by any person, other than permissible deductions as defined in Regulations, Part 3 (29 C.F.R. Subtitle A), issued by the Secretary of Labor under the Copeland Act, as amended (48 Stat. 948, 63 Stat. 108, 72 Stat. 967; 76 Stat. 357; 40 U.S.C. § 3145), and described below:

\_\_\_\_\_  
 \_\_\_\_\_  
 \_\_\_\_\_  
 \_\_\_\_\_

(2) That any payrolls otherwise under this contract required to be submitted for the above period are correct and complete; that the wage rates for laborers or mechanics contained therein are not less than the applicable wage rates contained in any wage determination incorporated into the contract; that the classifications set forth therein for each laborer or mechanic conform with the work he performed.

(3) That any apprentices employed in the above period are duly registered in a bona fide apprenticeship program registered with a State apprenticeship agency recognized by the Bureau of Apprenticeship and Training, United States Department of Labor, or if no such recognized agency exists in a State, are registered with the Bureau of Apprenticeship and Training, United States Department of Labor.

(4) That:

(a) WHERE FRINGE BENEFITS ARE PAID TO APPROVED PLANS, FUNDS, OR PROGRAMS

— in addition to the basic hourly wage rates paid to each laborer or mechanic listed in the above referenced payroll, payments of fringe benefits as listed in the contract have been or will be made to appropriate programs for the benefit of such employees, except as noted in section 4(c) below.

(b) WHERE FRINGE BENEFITS ARE PAID IN CASH

— Each laborer or mechanic listed in the above referenced payroll has been paid, as indicated on the payroll, an amount not less than the sum of the applicable basic hourly wage rate plus the amount of the required fringe benefits as listed in the contract, except as noted in section 4(c) below.

(c) EXCEPTIONS

EXCEPTION (CRAFT)	EXPLANATION

REMARKS:

NAME AND TITLE

SIGNATURE

THE WILLFUL FALSIFICATION OF ANY OF THE ABOVE STATEMENTS MAY SUBJECT THE CONTRACTOR OR SUBCONTRACTOR TO CIVIL OR CRIMINAL PROSECUTION. SEE SECTION 1001 OF TITLE 18 AND SECTION 231 OF TITLE 31 OF THE UNITED STATES CODE





U.S. Department of Housing and Urban Development  
Office of Departmental Operations and Coordination  
Washington, DC 20410

---

Email: [www.OfficeofLaborRelations@hud.gov](mailto:www.OfficeofLaborRelations@hud.gov)

**Labor Relations Desk Guide  
LR01.DG**



"General Decision Number: CA20230012 10/06/2023

Superseded General Decision Number: CA20220012

State: California

Construction Types: Building, Heavy (Heavy and Dredging) and Highway

County: San Luis Obispo County in California.

BUILDING, DREDGING (does not include hopper dredge work), HEAVY (does not include water well drilling, AND HIGHWAY CONSTRUCTION PROJECTS

Note: Contracts subject to the Davis-Bacon Act are generally required to pay at least the applicable minimum wage rate required under Executive Order 14026 or Executive Order 13658. Please note that these Executive Orders apply to covered contracts entered into by the federal government that are subject to the Davis-Bacon Act itself, but do not apply to contracts subject only to the Davis-Bacon Related Acts, including those set forth at 29 CFR 5.1(a)(2)-(60).

<p>If the contract is entered into on or after January 30, 2022, or the contract is renewed or extended (e.g., an option is exercised) on or after January 30, 2022:</p>	<ul style="list-style-type: none"> <li>. Executive Order 14026 generally applies to the contract.</li> <li>. The contractor must pay all covered workers at least \$16.20 per hour (or the applicable wage rate listed on this wage determination, if it is higher) for all hours spent performing on the contract in 2023.</li> </ul>
<p>If the contract was awarded on or between January 1, 2015 and January 29, 2022, and the contract is not renewed or extended on or after January 30, 2022:</p>	<ul style="list-style-type: none"> <li>. Executive Order 13658 generally applies to the contract.</li> <li>. The contractor must pay all covered workers at least \$12.15 per hour (or the applicable wage rate listed on this wage determination, if it is higher) for all hours spent performing on that contract in 2023.</li> </ul>

The applicable Executive Order minimum wage rate will be adjusted annually. If this contract is covered by one of the Executive Orders and a classification considered necessary for performance of work on the contract does not appear on this wage determination, the contractor must still submit a conformance request.

Additional information on contractor requirements and worker protections under the Executive Orders is available at <http://www.dol.gov/whd/govcontracts>.

0	01/06/2023
1	01/13/2023
2	02/10/2023
3	03/17/2023
4	04/07/2023
5	06/30/2023
6	08/11/2023
7	08/18/2023
8	09/08/2023
9	10/06/2023

ASBE0005-002 07/04/2022

	Rates	Fringes
Asbestos Workers/Insulator (Includes the application of all insulating materials, protective coverings, coatings, and finishes to all types of mechanical systems).....	\$ 49.58	25.27
Fire Stop Technician (Application of Firestopping Materials for wall openings and penetrations in walls, floors, ceilings and curtain walls).....	\$ 32.09	19.66

ASBE0005-004 07/04/2022

	Rates	Fringes
Asbestos Removal worker/hazardous material handler (Includes preparation, wetting, stripping, removal, scrapping, vacuuming, bagging and disposing of all insulation materials from mechanical systems, whether they contain asbestos or not)....	\$ 23.52	13.37

BOIL0092-004 01/01/2021

Area within a 25 mile radius of City of Santa Maria

	Rates	Fringes
BOILERMAKER.....	\$ 46.03	38.81

BOIL0549-007 01/01/2021

Remainder of County outside a 25 mile radius of City of Santa Maria

	Rates	Fringes
BOILERMAKER.....	\$ 45.60	38.99

\* BRCA0004-006 05/01/2020

	Rates	Fringes
BRICKLAYERS, MARBLE SETTERS, WIRERS, ROPE, SUPPLIERS, ATTACHERS, MODIFICATIONS AND EXHIBITS.....	\$ 44.83	17.51

\*The wage scale for prevailing wage projects performed in Blythe, China lake, Death Valley, Fort Irwin, Twenty-Nine Palms, Needles and 1-15 corridor (Barstow to the Nevada State Line) will be Three Dollars (\$3.00) above the standard San Bernardino/Riverside County hourly wage rate

-----  
BRCA0018-008 06/01/2022

	Rates	Fringes
MARBLE FINISHER.....	\$ 37.87	14.13
TILE FINISHER.....	\$ 32.44	12.54

-----  
BRCA0018-011 06/01/2022

	Rates	Fringes
TILE LAYER.....	\$ 45.05	18.33

-----  
CARP0213-001 07/01/2021

	Rates	Fringes
CARPENTER		
(1) Carpenter, Cabinet Installer, Insulation Installer, Hardwood Floor Worker and acoustical installer.....	\$ 51.60	16.28
(2) Millwright.....	\$ 52.10	16.48
(3) Piledrivermen/Derrick Bargeman, Bridge or Dock Carpenter, Heavy Frammer, Rock Bargeman or Scowman, Rockslinger, Shingler (Commercial).....	\$ 51.73	16.28
(4) Pneumatic Nailer, Power Stapler.....	\$ 51.85	16.28
(5) Sawfiler.....	\$ 51.69	16.28
(6) Scaffold Builder.....	\$ 42.80	16.28
(7) Table Power Saw Operator.....	\$ 51.70	16.28

FOOTNOTE: Work of forming in the construction of open cut sewers or storm drains, on operations in which horizontal lagging is used in conjunction with steel H-Beams driven or placed in pre- drilled holes, for that portion of a lagged trench against which concrete is poured, namely, as a substitute for back forms (which work is performed by piledrivers): \$0.13 per hour additional.

-----  
CARP0213-002 07/01/2021

	Rates	Fringes
Diver		
(1) Wet.....	\$ 834.40	16.28
(2) Standby.....	\$ 445.84	16.28
(3) Tender.....	\$ 437.84	16.28
(4) Assistant Tender.....	\$ 413.84	16.28

Amounts in ""Rates' column are per day

-----  
(vii) Reports, Supplements, Attachments,  
Modifications and Exhibits

CARP0213-004 07/01/2021

	Rates	Fringes
Drywall		
DRYWALL INSTALLER/LATHER....\$	51.60	16.28
STOCKER/SCRAPPER.....\$	22.16	8.62

-----  
CARP0721-001 07/01/2021

	Rates	Fringes
Modular Furniture Installer.....\$	21.85	7.15

-----  
ELEC0639-001 01/01/2023

	Rates	Fringes
Electricians		
Wireman/Technician.....\$	51.50	22.80

FOOTNOTES:

CABLE SPLICER: 10% additional per hour above Wireman/Technician basic hourly rate.

Work from trusses, swinging scaffolds, open ladders, scaffolds, bosun chairs, stacks or towers, where subject to a direct fall from the ground floor or support structure from a distance of fifty (50) feet to ninety (90) feet: to be paid time and one-half. Work from trusses, swinging scaffolds, open ladders, scaffolds, bosun chairs, stacks or towers, where subject to a direct fall from the ground floor or support structure from a distance over ninety (90) feet: to be paid double the regular straight time rate of pay. Where workers are required to work under compressed air or in areas where injurious gases, dust or fumes are present in amounts necessitating the use of gas masks or self-contained breathing apparatus (particle masks are not considered self-contained breathing apparatus) or where workers work on poles at a distance of seventy-five (75) feet or more from the ground: to be paid a bonus of straight time pay. This shall be at a minimum of one hour, and thereafter, each succeeding hour or fraction thereof shall constitute an hour at the bonus rate. Tunnel work: to be paid at the time and one-quarter hourly rate.

All employers may request workmen to report direct to a job within a free zone to include everything west of ten (10) miles east of Highway 101, as the crow flies, and then (10) miles north and south of Highway 46, as the crow flies, to the junction of Highway 41 and Highway 46. Everything outside this area shall be paid at full subsistence provide said job is of five (5) days duration or more and provide there is storage on the job for the Employee's tools. The Employer will be responsible for loss of tools under such circumstances. (Road: The most direct route on a surfaced road).

On all jobs or projects outside the free zone, as stated above, Employees may be required to report to the job site in their own transportation at the regular starting time and remain on the job site until the regular quitting time and these shall be paid at fifty dollars (\$50.00) per day or fifty-one cents (\$0.51) per mile for each road mile from shop to job and job to shop (round trip). (Day worked shall

(vii) Reports, Supplements, Attachments, Modifications and Exhibits

mean at least four (4) hours on the job unless sent home on account of weather, emergency, sickness, or injury).

The Employer shall pay for traveling time and furnish transportation from shop to job, job to job, and job to shop. Travel time shall be at the appropriate rate of pay for that day of the week. (Monday through Friday, straight time, Saturday and Sunday, double time.)

-----  
ELEC0639-003 12/27/2021

COMMUNICATIONS AND SYSTEMS WORK

SAN LUIS OBISPO COUNTY

	Rates	Fringes
Communications System		
Installer.....	\$ 41.68	15.90
Technician.....	\$ 30.89	11.66

SCOPE OF WORK: Installation, testing, service and maintenance of systems utilizing the transmission and/or transference of voice, sound, vision and digital for commercial, educational, security and entertainment purposes for the following: TV monitoring and surveillance, background - foreground music, intercom and telephone interconnect, microwave transmission, multi-media, multiplex, nurse call systems, radio page, burglar alarms and fire alarm (see last paragraph below).

Communication Systems that transmit or receive information and/or control systems that are intrinsic to the above listed systems; inclusion or exclusion of terminations and testings of conductors determined by their function; excluding all other data systems or multiple systems which include control function or power supply; excluding installation of raceway systems, conduit systems, line voltage work, and energy management systems.

Fire alarm work shall be performed at the current inside electrician total cost package.

-----  
ELEC1245-001 06/01/2022

	Rates	Fringes
LINE CONSTRUCTION		
(1) Lineman; Cable splicer..	\$ 64.40	22.58
(2) Equipment specialist (operates crawler tractors, commercial motor vehicles, backhoes, trenchers, cranes (50 tons and below), overhead & underground distribution line equipment).....	\$ 50.00	21.30
(3) Groundman.....	\$ 38.23	20.89
(4) Powderman.....	\$ 51.87	18.79

HOLIDAYS: New Year's Day, M.L. King Day, Memorial Day, Independence Day, Labor Day, Veterans Day, Thanksgiving Day and day after Thanksgiving, Christmas Day

(vii) Reports, Supplements, Attachments,  
Modifications and Exhibits

L - The General Decision Number  
CA20230012

-----  
ELEV0008-003 01/01/2023

	Rates	Fringes
ELEVATOR MECHANIC.....	\$ 77.61	37.335+a+b

FOOTNOTE:

a. PAID VACATION: Employer contributes 8% of regular hourly rate as vacation pay credit for employees with more than 5 years of service, and 6% for 6 months to 5 years of service.

b. PAID HOLIDAYS: New Year's Day, Memorial Day, Independence Day, Labor Day, Veterans' Day, Thanksgiving Day, Friday after Thanksgiving, and Christmas Day.

-----  
ENGI0012-003 07/01/2022

	Rates	Fringes
OPERATOR: Power Equipment (All Other Work)		
GROUP 1.....	\$ 51.90	30.70
GROUP 2.....	\$ 52.68	30.70
GROUP 3.....	\$ 52.97	30.70
GROUP 4.....	\$ 54.46	30.70
GROUP 5.....	\$ 48.96	25.25
GROUP 6.....	\$ 54.68	30.70
GROUP 8.....	\$ 54.79	30.70
GROUP 9.....	\$ 49.29	25.25
GROUP 10.....	\$ 54.91	30.70
GROUP 11.....	\$ 49.41	25.25
GROUP 12.....	\$ 55.08	30.70
GROUP 13.....	\$ 55.18	30.70
GROUP 14.....	\$ 55.21	30.70
GROUP 15.....	\$ 55.29	30.70
GROUP 16.....	\$ 55.41	30.70
GROUP 17.....	\$ 55.58	30.70
GROUP 18.....	\$ 55.68	30.70
GROUP 19.....	\$ 55.79	30.70
GROUP 20.....	\$ 55.91	30.70
GROUP 21.....	\$ 56.08	30.70
GROUP 22.....	\$ 56.18	30.70
GROUP 23.....	\$ 56.29	30.70
GROUP 24.....	\$ 56.41	30.70
GROUP 25.....	\$ 56.58	30.70
OPERATOR: Power Equipment (Cranes, Piledriving & Hoisting)		
GROUP 1.....	\$ 53.25	30.70
GROUP 2.....	\$ 54.03	30.70
GROUP 3.....	\$ 54.32	30.70
GROUP 4.....	\$ 54.46	30.70
GROUP 5.....	\$ 54.68	30.70
GROUP 6.....	\$ 54.79	30.70
GROUP 7.....	\$ 54.91	30.70
GROUP 8.....	\$ 55.08	30.70
GROUP 9.....	\$ 55.25	30.70
GROUP 10.....	\$ 56.25	30.70
GROUP 11.....	\$ 57.25	30.70
GROUP 12.....	\$ 58.25	30.70
GROUP 13.....	\$ 59.25	30.70
OPERATOR: Power Equipment (Tunnel Work)		
GROUP 1.....	\$ 54.53	30.70

Group Reports, Supplements, Attachments, Modifications and Exhibits

GROUP 2.....	\$ 54.82	30.70
GROUP 3.....	\$ 54.96	30.70
GROUP 4.....	\$ 55.18	30.70
GROUP 5.....	\$ 55.29	30.70
GROUP 6.....	\$ 55.41	30.70
GROUP 7.....	\$ 55.71	30.70

PREMIUM PAY:

\$3.75 per hour shall be paid on all Power Equipment Operator work on the following Military Bases: China Lake Naval Reserve, Vandenberg AFB, Point Arguello, Seely Naval Base, Fort Irwin, Nebo Annex Marine Base, Marine Corp Logistics Base Yermo, Edwards AFB, 29 Palms Marine Base and Camp Pendleton

Workers required to suit up and work in a hazardous material environment: \$2.00 per hour additional. Combination mixer and compressor operator on gunite work shall be classified as a concrete mobile mixer operator.

SEE ZONE DEFINITIONS AFTER CLASSIFICATIONS

POWER EQUIPMENT OPERATORS CLASSIFICATIONS

GROUP 1: Bargeman; Brakeman; Compressor operator; Ditch Witch, with seat or similar type equipment; Elevator operator-inside; Engineer Oiler; Forklift operator (includes loed, lull or similar types under 5 tons; Generator operator; Generator, pump or compressor plant operator; Pump operator; Signalman; Switchman

GROUP 2: Asphalt-rubber plant operator (nurse tank operator); Concrete mixer operator-skip type; Conveyor operator; Fireman; Forklift operator (includes loed, lull or similar types over 5 tons; Hydrostatic pump operator; oiler crusher (asphalt or concrete plant); Petromat laydown machine; PJU side dum jack; Screening and conveyor machine operator (or similar types); Skiploader (wheel type up to 3/4 yd. without attachment); Tar pot fireman; Temporary heating plant operator; Trenching machine oiler

GROUP 3: Asphalt-rubber blend operator; Bobcat or similar type (Skid steer); Equipment greaser (rack); Ford Ferguson (with dragtype attachments); Helicopter radioman (ground); Stationary pipe wrapping and cleaning machine operator

GROUP 4: Asphalt plant fireman; Backhoe operator (mini-max or similar type); Boring machine operator; Boxman or mixerman (asphalt or concrete); Chip spreading machine operator; Concrete cleaning decontamination machine operator; Concrete Pump Operator (small portable); Drilling machine operator, small auger types (Texoma super economatic or similar types - Hughes 100 or 200 or similar types - drilling depth of 30' maximum); Equipment greaser (grease truck); Guard rail post driver operator; Highline cableway signalman; Hydra-hammer-aero stomper; Micro Tunneling (above ground tunnel); Power concrete curing machine operator; Power concrete saw operator; Power-driven jumbo form setter operator; Power sweeper operator; Rock Wheel Saw/Trencher; Roller operator (compacting); Screed operator (asphalt or concrete); Trenching machine operator (up to 6 ft.); Vacuum or much truck

GROUP 5: Equipment Greaser (Grease Truck/Multi Shift).

GROUP 6: Articulating material hauler; Asphalt plant (vii) Reports, Supplements, Attachments, Modifications and Exhibits



engineer; Batch plant operator; Bit sharpener; Concrete joint machine operator (canal and similar type); Concrete planer operator; Dandy digger; Deck engine operator; Derrickman (oilfield type); Drilling machine operator, bucket or auger types (Calweld 100 bucket or similar types - Watson 1000 auger or similar types - Texoma 330, 500 or 600 auger or similar types - drilling depth of 45' maximum); Drilling machine operator; Hydrographic seeder machine operator (straw, pulp or seed), Jackson track maintainer, or similar type; Kalamazoo Switch tamper, or similar type; Machine tool operator; Maginnis internal full slab vibrator, Mechanical berm, curb or gutter (concrete or asphalt); Mechanical finisher operator (concrete, Clary-Johnson-Bidwell or similar); Micro tunnel system (below ground); Pavement breaker operator (truck mounted); Road oil mixing machine operator; Roller operator (asphalt or finish), rubber-tired earth moving equipment (single engine, up to and including 25 yds. struck); Self-propelled tar pipelining machine operator; Skiploader operator (crawler and wheel type, over 3/4 yd. and up to and including 1-1/2 yds.); Slip form pump operator (power driven hydraulic lifting device for concrete forms); Tractor operator-bulldozer, tamper-scraper (single engine, up to 100 h.p. flywheel and similar types, up to and including D-5 and similar types); Tugger hoist operator (1 drum); Ultra high pressure waterjet cutting tool system operator; Vacuum blasting machine operator

GROUP 8: Asphalt or concrete spreading operator (tamping or finishing); Asphalt paving machine operator (Barber Greene or similar type); Asphalt-rubber distribution operator; Backhoe operator (up to and including 3/4 yd.), small ford, Case or similar; Cast-in-place pipe laying machine operator; Combination mixer and compressor operator (gunite work); Compactor operator (self-propelled); Concrete mixer operator (paving); Crushing plant operator; Drill Doctor; Drilling machine operator, Bucket or auger types (Calweld 150 bucket or similar types - Watson 1500, 2000 2500 auger or similar types - Texoma 700, 800 auger or similar types - drilling depth of 60' maximum); Elevating grader operator; Grade checker; Gradall operator; Grouting machine operator; Heavy-duty repairman; Heavy equipment robotics operator; Kalamazoo balliste regulator or similar type; Kolman belt loader and similar type; Le Tourneau blob compactor or similar type; Loader operator (Athey, Euclid, Sierra and similar types); Mobark Chipper or similar; Ozzie padder or similar types; P.C. slot saw; Pneumatic concrete placing machine operator (Hackley-Presswell or similar type); Pumpcrete gun operator; Rock Drill or similar types; Rotary drill operator (excluding caisson type); Rubber-tired earth-moving equipment operator (single engine, caterpillar, Euclid, Athey Wagon and similar types with any and all attachments over 25 yds. up to and including 50 cu. yds. struck); Rubber-tired earth-moving equipment operator (multiple engine up to and including 25 yds. struck); Rubber-tired scraper operator (self-loading paddle wheel type-John Deere, 1040 and similar single unit); Self-propelled curb and gutter machine operator; Shuttle buggy; Skiploader operator (crawler and wheel type over 1-1/2 yds. up to and including 6-1/2 yds.); Soil remediation plant operator; Surface heaters and planer operator; Tractor compressor drill combination operator; Tractor operator (any type larger than D-5 - 100 flywheel h.p. and over, or similar-bulldozer, tamper, scraper and push tractor single engine); Tractor operator (boom attachments), Traveling pipe repair, cleaning and bonding machine operator;

Wages, Salaries, and Benefits, Attachments, Modifications and Exhibits

Trenching machine operator (over 6 ft. depth capacity, manufacturer's rating); trenching Machine with Road Miner attachment (over 6 ft depth capacity): Ultra high pressure waterjet cutting tool system mechanic; Water pull (compaction) operator

GROUP 9: Heavy Duty Repairman

GROUP 10: Drilling machine operator, Bucket or auger types (Calweld 200 B bucket or similar types-Watson 3000 or 5000 auger or similar types-Texoma 900 auger or similar types-drilling depth of 105' maximum); Dual drum mixer, dynamic compactor LDC350 (or similar types); Monorail locomotive operator (diesel, gas or electric); Motor patrol-blade operator (single engine); Multiple engine tractor operator (Euclid and similar type-except Quad 9 cat.); Rubber-tired earth-moving equipment operator (single engine, over 50 yds. struck); Pneumatic pipe ramming tool and similar types; Prestressed wrapping machine operator; Rubber-tired earth-moving equipment operator (single engine, over 50 yds. struck); Rubber tired earth moving equipment operator (multiple engine, Euclid, caterpillar and similar over 25 yds. and up to 50 yds. struck), Tower crane repairman; Tractor loader operator (crawler and wheel type over 6-1/2 yds.); Woods mixer operator (and similar Pugmill equipment)

GROUP 11: Heavy Duty Repairman - Welder Combination, Welder - Certified.

GROUP 12: Auto grader operator; Automatic slip form operator; Drilling machine operator, bucket or auger types (Calweld, auger 200 CA or similar types - Watson, auger 6000 or similar types - Hughes Super Duty, auger 200 or similar types - drilling depth of 175' maximum); Hoe ram or similar with compressor; Mass excavator operator less tha 750 cu. yards; Mechanical finishing machine operator; Mobile form traveler operator; Motor patrol operator (multi-engine); Pipe mobile machine operator; Rubber-tired earth- moving equipment operator (multiple engine, Euclid, Caterpillar and similar type, over 50 cu. yds. struck); Rubber-tired self- loading scraper operator (paddle-wheel-auger type self-loading - two (2) or more units)

GROUP 13: Rubber-tired earth-moving equipment operator operating equipment with push-pull system (single engine, up to and including 25 yds. struck)

GROUP 14: Canal liner operator; Canal trimmer operator; Remote- control earth-moving equipment operator (operating a second piece of equipment: \$1.00 per hour additional); Wheel excavator operator (over 750 cu. yds.)

GROUP 15: Rubber-tired earth-moving equipment operator, operating equipment with push-pull system (single engine, Caterpillar, Euclid, Athey Wagon and similar types with any and all attachments over 25 yds. and up to and including 50 yds. struck); Rubber-tired earth-moving equipment operator, operating equipment with push-pull system (multiple engine-up to and including 25 yds. struck)

GROUP 16: Rubber-tired earth-moving equipment operator, operating equipment with push-pull system (single engine, over 50 yds. struck); Rubber-tired earth-moving equipment operator, operating equipment with push-pull system (multiple engine, Euclid, Caterpillar and similar, over 25

(vii) Reports, Supplements, Attachments,

Modifications and Exhibits

yds. and up to 50 yds. struck)

GROUP 17: Rubber-tired earth-moving equipment operator, operating equipment with push-pull system (multiple engine, Euclid, Caterpillar and similar, over 50 cu. yds. struck); Tandem tractor operator (operating crawler type tractors in tandem - Quad 9 and similar type)

GROUP 18: Rubber-tired earth-moving equipment operator, operating in tandem (scrapers, belly dumps and similar types in any combination, excluding compaction units - single engine, up to and including 25 yds. struck)

GROUP 19: Rotex concrete belt operator (or similar types); Rubber-tired earth-moving equipment operator, operating in tandem (scrapers, belly dumps and similar types in any combination, excluding compaction units - single engine, Caterpillar, Euclid, Athey Wagon and similar types with any and all attachments over 25 yds. and up to and including 50 cu. yds. struck); Rubber-tired earth-moving equipment operator, operating in tandem (scrapers, belly dumps and similar types in any combination, excluding compaction units - multiple engine, up to and including 25 yds. struck)

GROUP 20: Rubber-tired earth-moving equipment operator, operating in tandem (scrapers, belly dumps and similar types in any combination, excluding compaction units - single engine, over 50 yds. struck); Rubber-tired earth-moving equipment operator, operating in tandem (scrapers, belly dumps, and similar types in any combination, excluding compaction units - multiple engine, Euclid, Caterpillar and similar, over 25 yds. and up to 50 yds. struck)

GROUP 21: Rubber-tired earth-moving equipment operator, operating in tandem (scrapers, belly dumps and similar types in any combination, excluding compaction units - multiple engine, Euclid, Caterpillar and similar type, over 50 cu. yds. struck)

GROUP 22: Rubber-tired earth-moving equipment operator, operating equipment with the tandem push-pull system (single engine, up to and including 25 yds. struck)

GROUP 23: Rubber-tired earth-moving equipment operator, operating equipment with the tandem push-pull system (single engine, Caterpillar, Euclid, Athey Wagon and similar types with any and all attachments over 25 yds. and up to and including 50 yds. struck); Rubber-tired earth-moving equipment operator, operating with the tandem push-pull system (multiple engine, up to and including 25 yds. struck)

GROUP 24: Rubber-tired earth-moving equipment operator, operating equipment with the tandem push-pull system (single engine, over 50 yds. struck); Rubber-tired earth-moving equipment operator, operating equipment with the tandem push-pull system (multiple engine, Euclid, Caterpillar and similar, over 25 yds. and up to 50 yds. struck)

GROUP 25: Concrete pump operator-truck mounted; Rubber-tired earth-moving equipment operator, operating equipment with the tandem push-pull system (multiple engine, Euclid, Caterpillar and similar type, over 50 cu. yds. struck)

(vii) Reports, Supplements, Attachments,

Modifications and Exhibits

## CRANES, PILEDIVING AND HOISTING EQUIPMENT CLASSIFICATIONS

GROUP 1: Engineer oiler; Fork lift operator (includes loed, lull or similar types)

GROUP 2: Truck crane oiler

GROUP 3: A-frame or winch truck operator; Ross carrier operator (jobsite)

GROUP 4: Bridge-type unloader and turntable operator; Helicopter hoist operator

GROUP 5: Hydraulic boom truck; Stinger crane (Austin-Western or similar type); Tugger hoist operator (1 drum)

GROUP 6: Bridge crane operator; Cretor crane operator; Hoist operator (Chicago boom and similar type); Lift mobile operator; Lift slab machine operator (Vagtborg and similar types); Material hoist and/or manlift operator; Polar gantry crane operator; Self Climbing scaffold (or similar type); Shovel, backhoe, dragline, clamshell operator (over 3/4 yd. and up to 5 cu. yds. mrc); Tugger hoist operator

GROUP 7: Pedestal crane operator; Shovel, backhoe, dragline, clamshell operator (over 5 cu. yds. mrc); Tower crane repair; Tugger hoist operator (3 drum)

GROUP 8: Crane operator (up to and including 25 ton capacity); Crawler transporter operator; Derrick barge operator (up to and including 25 ton capacity); Hoist operator, stiff legs, Guy derrick or similar type (up to and including 25 ton capacity); Shovel, backhoe, dragline, clamshell operator (over 7 cu. yds., M.R.C.)

GROUP 9: Crane operator (over 25 tons and up to and including 50 tons mrc); Derrick barge operator (over 25 tons up to and including 50 tons mrc); Highline cableway operator; Hoist operator, stiff legs, Guy derrick or similar type (over 25 tons up to and including 50 tons mrc); K-crane operator; Polar crane operator; Self erecting tower crane operator maximum lifting capacity ten tons

GROUP 10: Crane operator (over 50 tons and up to and including 100 tons mrc); Derrick barge operator (over 50 tons up to and including 100 tons mrc); Hoist operator, stiff legs, Guy derrick or similar type (over 50 tons up to and including 100 tons mrc), Mobile tower crane operator (over 50 tons, up to and including 100 tons M.R.C.); Tower crane operator and tower gantry

GROUP 11: Crane operator (over 100 tons and up to and including 200 tons mrc); Derrick barge operator (over 100 tons up to and including 200 tons mrc); Hoist operator, stiff legs, Guy derrick or similar type (over 100 tons up to and including 200 tons mrc); Mobile tower crane operator (over 100 tons up to and including 200 tons mrc)

GROUP 12: Crane operator (over 200 tons up to and including 300 tons mrc); Derrick barge operator (over 200 tons up to and including 300 tons mrc); Hoist operator, stiff legs, Guy derrick or similar type (over 200 tons, up to and including 300 tons mrc); Mobile tower crane operator (over 200 tons, up to and including 300 tons mrc)

GROUP 13: Crane operator (over 300 tons); Derrick barge

(vii) Reports, Supplements, Attachments,

Modifications and Exhibits

operator (over 300 tons); Helicopter pilot; Hoist operator, stiff legs, Guy derrick or similar type (over 300 tons); Mobile tower crane operator (over 300 tons)

#### TUNNEL CLASSIFICATIONS

GROUP 1: Skiploader (wheel type up to 3/4 yd. without attachment)

GROUP 2: Power-driven jumbo form setter operator

GROUP 3: Dinkey locomotive or motorperson (up to and including 10 tons)

GROUP 4: Bit sharpener; Equipment greaser (grease truck); Slip form pump operator (power-driven hydraulic lifting device for concrete forms); Tugger hoist operator (1 drum); Tunnel locomotive operator (over 10 and up to and including 30 tons)

GROUP 5: Backhoe operator (up to and including 3/4 yd.); Small Ford, Case or similar; Drill doctor; Grouting machine operator; Heading shield operator; Heavy-duty repairperson; Loader operator (Athey, Euclid, Sierra and similar types); Mucking machine operator (1/4 yd., rubber-tired, rail or track type); Pneumatic concrete placing machine operator (Hackley-Presswell or similar type); Pneumatic heading shield (tunnel); Pumpcrete gun operator; Tractor compressor drill combination operator; Tugger hoist operator (2 drum); Tunnel locomotive operator (over 30 tons)

GROUP 6: Heavy Duty Repairman

GROUP 7: Tunnel mole boring machine operator

#### ENGINEERS ZONES

\$1.00 additional per hour for all of IMPERIAL County and the portions of KERN, RIVERSIDE & SAN BERNARDINO Counties as defined below:

That area within the following Boundary: Begin in San Bernardino County, approximately 3 miles NE of the intersection of I-15 and the California State line at that point which is the NW corner of Section 1, T17N,m R14E, San Bernardino Meridian. Continue W in a straight line to that point which is the SW corner of the northwest quarter of Section 6, T27S, R42E, Mt. Diablo Meridian. Continue North to the intersection with the Inyo County Boundary at that point which is the NE corner of the western half of the northern quarter of Section 6, T25S, R42E, MDM. Continue W along the Inyo and San Bernardino County boundary until the intersection with Kern County, as that point which is the SE corner of Section 34, T24S, R40E, MDM. Continue W along the Inyo and Kern County boundary until the intersection with Tulare County, at that point which is the SW corner of the SE quarter of Section 32, T24S, R37E, MDM. Continue W along the Kern and Tulare County boundary, until that point which is the NW corner of T25S, R32E, MDM. Continue S following R32E lines to the NW corner of T31S, R32E, MDM. Continue W to the NW corner of T31S, R31E, MDM. Continue S to the SW corner of T32S, R31E, MDM. Continue W to SW corner of SE quarter of Section 34, T32S, R30E, MDM. Continue S to SW corner of T11N, R17W, SBM. Continue E along south boundary of T11N, SBM to SW corner of T11N, R7W, SBM. Continue S to SW corner of T9N, R7W, SBM. Continue E along south boundary of T9N, SBM to SW corner of T9N, R1E, SBM.

(vii) Reports, Supplements, Attachments,

Modifications and Exhibits

Continue S along west boundary of R1E, SMB to Riverside County line at the SW corner of T1S, R1E, SBM. Continue E along south boundary of T1s, SBM (Riverside County Line) to SW corner of T1S, R10E, SBM. Continue S along west boundary of R10E, SBM to Imperial County line at the SW corner of T8S, R10E, SBM. Continue W along Imperial and Riverside county line to NW corner of T9S, R9E, SBM. Continue S along the boundary between Imperial and San Diego Counties, along the west edge of R9E, SBM to the south boundary of Imperial County/California state line. Follow the California state line west to Arizona state line, then north to Nevada state line, then continuing NW back to start at the point which is the NW corner of Section 1, T17N, R14E, SBM

\$1.00 additional per hour for portions of SAN LUIS OBISPO, KERN, SANTA BARBARA & VENTURA as defined below:

That area within the following Boundary: Begin approximately 5 miles north of the community of Cholame, on the Monterey County and San Luis Obispo County boundary at the NW corner of T25S, R16E, Mt. Diablo Meridian. Continue south along the west side of R16E to the SW corner of T30S, R16E, MDM. Continue E to SW corner of T30S, R17E, MDM. Continue S to SW corner of T31S, R17E, MDM. Continue E to SW corner of T31S, R18E, MDM. Continue S along West side of R18E, MDM as it crosses into San Bernardino Meridian numbering area and becomes R30W. Follow the west side of R30W, SBM to the SW corner of T9N, R30W, SBM. Continue E along the south edge of T9N, SBM to the Santa Barbara County and Ventura County boundary at that point which is the SW corner of Section 34. T9N, R24W, SBM, continue S along the Ventura County line to that point which is the SW corner of the SE quarter of Section 32, T7N, R24W, SBM. Continue E along the south edge of T7N, SBM to the SE corner to T7N, R21W, SBM. Continue N along East side of R21W, SBM to Ventura County and Kern County boundary at the NE corner of T8N, R21W. Continue W along the Ventura County and Kern County boundary to the SE corner of T9N, R21W. Continue North along the East edge of R21W, SBM to the NE corner of T12N, R21W, SBM. Continue West along the north edge of T12N, SBM to the SE corner of T32S, R21E, MDM. [T12N SBM is a thin strip between T11N SBM and T32S MDM]. Continue North along the East side of R21E, MDM to the Kings County and Kern County border at the NE corner of T25S, R21E, MDM, continue West along the Kings County and Kern County Boundary until the intersection of San Luis Obispo County. Continue west along the Kings County and San Luis Obispo County boundary until the intersection with Monterey County. Continue West along the Monterey County and San Luis Obispo County boundary to the beginning point at the NW corner of T25S, R16E, MDM.

\$2.00 additional per hour for INYO and MONO Counties and the Northern portion of SAN BERNARDINO County as defined below:

That area within the following Boundary: Begin at the intersection of the northern boundary of Mono County and the California state line at the point which is the center of Section 17, T10N, R22E, Mt. Diablo Meridian. Continue S then SE along the entire western boundary of Mono County, until it reaches Inyo County at the point which is the NE corner of the Western half of the NW quarter of Section 2, T8S, R29E, MDM. Continue SSE along the entire western boundary of Inyo County, until the intersection with Kern County at the point which is the SW corner of the SE 1/4 of Section 32, T24S, R37E, MDM. Continue E along the Inyo and Kern County boundary until the intersection with San Bernardino County at that point which is

(vii) Reports, Supplements, Attachments,

Modifications and Exhibits

the SE corner of section 34, T24S, R40E, MDM. Continue E along the Inyo and San Bernardino County boundary until the point which is the NE corner of the Western half of the NW quarter of Section 6, T25S, R42E, MDM. Continue S to that point which is the SW corner of the NW quarter of Section 6, T27S, R42E, MDM. Continue E in a straight line to the California and Nevada state border at the point which is the NW corner of Section 1, T17N, R14E, San Bernardino Meridian. Then continue NW along the state line to the starting point, which is the center of Section 18, T10N, R22E, MDM.

REMAINING AREA NOT DEFINED ABOVE RECIEVES BASE RATE

-----  
ENGI0012-004 08/01/2023

	Rates	Fringes
OPERATOR: Power Equipment (DREDGING)		
(1) Leverman.....	\$ 64.10	34.60
(2) Dredge dozer.....	\$ 58.13	34.60
(3) Deckmate.....	\$ 58.02	34.60
(4) Winch operator (stern winch on dredge).....	\$ 57.47	34.60
(5) Fireman-Oiler, Deckhand, Bargeman, Leveehand.....	\$ 56.93	34.60
(6) Barge Mate.....	\$ 57.54	34.60

-----  
IRON0433-006 01/01/2023

	Rates	Fringes
IRONWORKER		
Fence Erector.....	\$ 41.28	25.66
Ornamental, Reinforcing and Structural.....	\$ 46.20	34.30

PREMIUM PAY:

\$9.00 additional per hour at the following locations:

China Lake Naval Test Station, Chocolate Mountains Naval Reserve-Niland, Edwards AFB, Fort Irwin Military Station, Fort Irwin Training Center-Goldstone, San Clemente Island, San Nicholas Island, Susanville Federal Prison, 29 Palms - Marine Corps, U.S. Marine Base - Barstow, U.S. Naval Air Facility - Sealey, Vandenberg AFB Army Defense Language Institute - Monterey, Fallon Air Base, Naval Post Graduate School - Monterey, Yermo Marine Corps Logistics Center  
Port Hueneme, Port Mugu, U.S. Coast Guard Station - Two Rock

-----  
LABO0220-001 07/01/2022

	Rates	Fringes
LABORER (TUNNEL)		
GROUP 1.....	\$ 45.68	23.30
GROUP 2.....	\$ 46.00	23.30
GROUP 3.....	\$ 46.46	23.30
GROUP 4.....	\$ 47.15	23.30

(V) Reports, Supplements, Attachments,  
Modifications and Exhibits

LABORER

GROUP 1.....	\$ 36.39	21.04
GROUP 2.....	\$ 36.94	21.04
GROUP 3.....	\$ 37.49	21.04
GROUP 4.....	\$ 39.04	21.04
GROUP 5.....	\$ 39.39	21.04

LABORER CLASSIFICATIONS

GROUP 1: Cleaning and handling of panel forms; Concrete screeding for rough strike-off; Concrete, water curing; Demolition laborer, the cleaning of brick if performed by a worker performing any other phase of demolition work, and the cleaning of lumber; Fire watcher, limber, brush loader, piler and debris handler; Flag person; Gas, oil and/or water pipeline laborer; Laborer, asphalt-rubber material loader; Laborer, general or construction; Laborer, general clean-up; Laborer, landscaping; Laborer, jetting; Laborer, temporary water and air lines; Material hose operator (walls, slabs, floors and decks); Plugging, filling of shee bolt holes; Dry packing of concrete; Railroad maintenance, repair track person and road beds; Streetcar and railroad construction track laborers; Rigging and signaling; Scaler; Slip form raiser; Tar and mortar; Tool crib or tool house laborer; Traffic control by any method; Window cleaner; Wire mesh pulling - all concrete pouring operations

GROUP 2: Asphalt shoveler; Cement dumper (on 1 yd. or larger mixer and handling bulk cement); Cesspool digger and installer; Chucktender; Chute handler, pouring concrete, the handling of the chute from readymix trucks, such as walls, slabs, decks, floors, foundation, footings, curbs, gutters and sidewalks; Concrete curer, impervious membrane and form oiler; Cutting torch operator (demolition); Fine grader, highways and street paving, airport, runways and similar type heavy construction; Gas, oil and/or water pipeline wrapper - pot tender and form person; Guinea chaser; Headerboard person - asphalt; Laborer, packing rod steel and pans; Membrane vapor barrier installer; Power broom sweeper (small); Riprap stonepaver, placing stone or wet sacked concrete; Roto scraper and tiller; Sandblaster (pot tender); Septic tank digger and installer(lead); Tank scaler and cleaner; Tree climber, faller, chain saw operator, Pittsburgh chipper and similar type brush shredder; Underground laborer, including caisson bellower

GROUP 3: Buggymobile person; Concrete cutting torch; Concrete pile cutter; Driller, jackhammer, 2-1/2 ft. drill steel or longer; Dri-pak-it machine; Gas, oil and/or water pipeline wrapper, 6-in. pipe and over, by any method, inside and out; High scaler (including drilling of same); Hydro seeder and similar type; Impact wrench multi-plate; Kettle person, pot person and workers applying asphalt, lay-kold, creosote, lime caustic and similar type materials ("applying" means applying, dipping, brushing or handling of such materials for pipe wrapping and waterproofing); Operator of pneumatic, gas, electric tools, vibrating machine, pavement breaker, air blasting, come-alongs, and similar mechanical tools not separately classified herein; Pipelayer's backup person, coating, grouting, making of joints, sealing, caulking, diapering and including rubber gasket joints, pointing and any and all other services; Rock slinger; Rotary scarifier or multiple head concrete chipping scarifier; Steel headerboard and guideline setter; Tamper, Barko, Wacker and similar type; Trenching machine, hand-propelled



GROUP 4: Asphalt raker, lute person, ironer, asphalt dump person, and asphalt spreader boxes (all types); Concrete core cutter (walls, floors or ceilings), grinder or sander; Concrete saw person, cutting walls or flat work, scoring old or new concrete; Cribber, shorer, lagging, sheeting and trench bracing, hand-guided lagging hammer; Head rock slinger; Laborer, asphalt- rubber distributor boot person; Laser beam in connection with laborers' work; Oversize concrete vibrator operator, 70 lbs. and over; Pipelayer performing all services in the laying and installation of pipe from the point of receiving pipe in the ditch until completion of operation, including any and all forms of tubular material, whether pipe, metallic or non-metallic, conduit and any other stationary type of tubular device used for the conveying of any substance or element, whether water, sewage, solid gas, air, or other product whatsoever and without regard to the nature of material from which the tubular material is fabricated; No-joint pipe and stripping of same; Prefabricated manhole installer; Sandblaster (nozzle person), water blasting, Porta Shot-Blast

GROUP 5: Blaster powder, all work of loading holes, placing and blasting of all powder and explosives of whatever type, regardless of method used for such loading and placing; Driller: All power drills, excluding jackhammer, whether core, diamond, wagon, track, multiple unit, and any and all other types of mechanical drills without regard to the form of motive power; Toxic waste removal

TUNNEL LABORER CLASSIFICATIONS

GROUP 1: Batch plant laborer; Changehouse person; Dump person; Dump person (outside); Swamper (brake person and switch person on tunnel work); Tunnel materials handling person; Nipper; Pot tender, using mastic or other materials (for example, but not by way of limitation, shotcrete, etc.);

GROUP 2: Bull gang mucker, track person; Chucktender, Cabletender; Concrete crew, including rodder and spreader; Loading and unloading agitator cars; Vibrator person, jack hammer, pneumatic tools (except driller)

GROUP 3: Blaster, driller, powder person; Chemical grout jet person; Cherry picker person; Grout gun person; Grout mixer person; Grout pump person; Jackleg miner; Jumbo person; Kemper and other pneumatic concrete placer operator; Miner, tunnel (hand or machine); Nozzle person; Operating of troweling and/or grouting machines; Powder person (primer house); Primer person; Sandblaster; Shotcrete person; Steel form raiser and setter; Timber person, retimber person, wood or steel; Tunnel Concrete finisher

GROUP 4: Diamond driller; Sandblaster; Shaft and raise work

-----  
LAB00220-004 07/01/2022

	Rates	Fringes
Brick Tender.....	\$ 37.32	21.45

-----  
LAB00300-005 08/01/2022

Asbestos Removal Laborer.....\$ 39.23 23.28

SCOPE OF WORK: Includes site mobilization, initial site cleanup, site preparation, removal of asbestos-containing material and toxic waste, encapsulation, enclosure and disposal of asbestos- containing materials and toxic waste by hand or with equipment or machinery; scaffolding, fabrication of temporary wooden barriers and assembly of decontamination stations.

-----  
LAB00345-001 07/01/2022

	Rates	Fringes
LABORER (GUNITE)		
GROUP 1.....	\$ 48.50	21.37
GROUP 2.....	\$ 47.55	21.37
GROUP 3.....	\$ 44.01	21.37

FOOTNOTE: GUNITE PREMIUM PAY: Workers working from a Bosn'n's Chair or suspended from a rope or cable shall receive 40 cents per hour above the foregoing applicable classification rates. Workers doing gunite and/or shotcrete work in a tunnel shall receive 35 cents per hour above the foregoing applicable classification rates, paid on a portal-to-portal basis. Any work performed on, in or above any smoke stack, silo, storage elevator or similar type of structure, when such structure is in excess of 75'-0"" above base level and which work must be performed in whole or in part more than 75'-0"" above base level, that work performed above the 75'-0"" level shall be compensated for at 35 cents per hour above the applicable classification wage rate.

GUNITE LABORER CLASSIFICATIONS

- GROUP 1: Rodmen, Nozzlemen
- GROUP 2: Gunmen
- GROUP 3: Reboundmen

-----  
LAB01184-001 07/01/2022

	Rates	Fringes
Laborers: (HORIZONTAL DIRECTIONAL DRILLING)		
(1) Drilling Crew Laborer...	\$ 40.69	18.25
(2) Vehicle Operator/Hauler.	\$ 40.86	18.25
(3) Horizontal Directional Drill Operator.....	\$ 42.71	18.25
(4) Electronic Tracking Locator.....	\$ 44.71	18.25
Laborers: (STRIPING/SLURRY SEAL)		
GROUP 1.....	\$ 41.90	21.32
GROUP 2.....	\$ 43.20	21.32
GROUP 3.....	\$ 45.21	21.32
GROUP 4.....	\$ 46.95	21.32

LABORERS - STRIPING CLASSIFICATIONS

(vii) Reports, Supplements, Attachments, Modifications and Exhibits

GROUP 1: Protective coating, pavement sealing, including repair and filling of cracks by any method on any surface in parking lots, game courts and playgrounds; carstops; operation of all related machinery and equipment; equipment repair technician

GROUP 2: Traffic surface abrasive blaster; pot tender - removal of all traffic lines and markings by any method (sandblasting, waterblasting, grinding, etc.) and preparation of surface for coatings. Traffic control person: controlling and directing traffic through both conventional and moving lane closures; operation of all related machinery and equipment

GROUP 3: Traffic delineating device applicator: Layout and application of pavement markers, delineating signs, rumble and traffic bars, adhesives, guide markers, other traffic delineating devices including traffic control. This category includes all traffic related surface preparation (sandblasting, waterblasting, grinding) as part of the application process. Traffic protective delineating system installer: removes, relocates, installs, permanently affixed roadside and parking delineation barricades, fencing, cable anchor, guard rail, reference signs, monument markers; operation of all related machinery and equipment; power broom sweeper

GROUP 4: Striper: layout and application of traffic stripes and markings; hot thermo plastic; tape traffic stripes and markings, including traffic control; operation of all related machinery and equipment

-----  
LAB01414-001 08/03/2022

	Rates	Fringes
LABORER		
PLASTER CLEAN-UP LABORER....	\$ 38.92	23.32
PLASTER TENDER.....	\$ 41.47	23.32

Work on a swing stage scaffold: \$1.00 per hour additional.

-----  
PAIN0036-007 07/01/2023

	Rates	Fringes
Painters:		
(1) Repaint Including Lead Abatement.....	\$ 25.40	15.87
(2) High Iron & Steel.....	\$ 32.12	16.03
(3) Journeyman Painter including Lead Abatement....	\$ 36.44	18.58
(4) Industrial.....	\$ 41.42	19.04
(5) All other work.....	\$ 36.44	18.58

REPAINT of any previously painted structure. Exceptions: work involving the aerospace industry, breweries, commercial recreational facilities, hotels which operate commercial establishments as part of hotel service, and sports facilities.

HIGH IRON & STEEL:

Aerial towers, towers, radio towers, smoke stacks, flag poles (any flag poles that can be finished from the ground with a ladder excluded), elevated water towers, steeples and domes in their entirety, and any other extremely high and hazardous work, (VII) Reports, Supplements, Attachments, Modifications and Exhibits

cooning steel, bos'n chair, or other similar devices, painting in other high hazardous work shall be classified as high iron & steel

-----  
PAIN0036-008 09/01/2022

	Rates	Fringes
DRYWALL FINISHER/TAPER.....	\$ 46.28	23.52

-----  
PAIN0169-002 01/01/2023

	Rates	Fringes
GLAZIER.....	\$ 44.33	28.88

-----  
PAIN1247-002 01/01/2023

	Rates	Fringes
SOFT FLOOR LAYER.....	\$ 41.60	16.38

-----  
PLAS0200-001 08/03/2022

	Rates	Fringes
PLASTERER.....	\$ 47.37	19.64

-----  
PLAS0500-002 07/01/2020

	Rates	Fringes
CEMENT MASON/CONCRETE FINISHER...	\$ 38.50	25.91

-----  
\* PLUM0016-001 09/01/2023

	Rates	Fringes
PLUMBER/PIPEFITTER Work ONLY on new additions and remodeling of bars, restaurant, stores and commercial buildings not to exceed 5,000 sq. ft. of floor space.....	\$ 53.51	25.28
Work ONLY on strip malls, light commercial, tenant improvement and remodel work.....	\$ 42.49	23.86
All other work except work on new additions and remodeling of bars, restaurant, stores and commercial buildings not to exceed 5,000 sq. ft. of floor space and work on strip malls, light commercial, tenant improvement and remodel work.....	\$ 55.18	26.26

-----  
PLUM0345-001 09/01/2023

(vii) Reports, Supplements, Attachments,  
Modifications and Exhibits

Rates Fringes

L - The General Decision Number  
CA20230012

PLUMBER

Landscape/Irrigation Fitter..\$	40.20	25.90
Sewer & Storm Drain Work....\$	44.29	23.28

-----  
 ROOF0036-002 08/01/2022

	Rates	Fringes
ROOFER.....	\$ 43.47	19.52

FOOTNOTE: Pitch premium: Work on which employees are exposed to pitch fumes or required to handle pitch, pitch base or pitch impregnated products, or any material containing coal tar pitch, the entire roofing crew shall receive \$1.75 per hour ""pitch premium"" pay.

-----  
 SFCA0669-014 04/01/2023

	Rates	Fringes
SPRINKLER FITTER.....	\$ 44.32	27.25

-----  
 SHEE0273-002 08/01/2019

	Rates	Fringes
SHEET METAL WORKER.....	\$ 45.48	30.05

HOLIDAYS: New Year's Day, Martin Luther King Day, President's Day, Good Friday, Memorial Day, Independence Day, Labor Day, Veterans Day, Thanksgiving Day & Friday after, Christmas Day

-----  
 TEAM0011-002 07/01/2023

	Rates	Fringes
TRUCK DRIVER		
GROUP 1.....	\$ 38.19	33.69
GROUP 2.....	\$ 38.34	33.69
GROUP 3.....	\$ 38.47	33.69
GROUP 4.....	\$ 38.66	33.69
GROUP 5.....	\$ 38.69	33.69
GROUP 6.....	\$ 38.72	33.69
GROUP 7.....	\$ 38.97	33.69
GROUP 8.....	\$ 39.22	33.69
GROUP 9.....	\$ 39.42	33.69
GROUP 10.....	\$ 39.72	33.69
GROUP 11.....	\$ 40.22	33.69
GROUP 12.....	\$ 40.65	33.69

WORK ON ALL MILITARY BASES:

PREMIUM PAY: \$3.00 per hour additional.

[29 palms Marine Base, Camp Roberts, China Lake, Edwards AFB, El Centro Naval Facility, Fort Irwin, Marine Corps Logistics Base at Nebo & Yermo, Mountain Warfare Training Center, Bridgeport, Point Arguello, Point Conception, Vandenberg AFB]

TRUCK DRIVERS CLASSIFICATIONS

GROUP 1: Truck driver

GROUP 2: Driver of vehicle or combination of vehicles - 2 axles; Traffic control pilot car excluding moving heavy equipment permit load; Truck mounted broom

GROUP 3: Driver of vehicle or combination of vehicles - 3 axles; Boot person; Cement mason distribution truck; Fuel truck driver; Water truck - 2 axle; Dump truck, less than 16 yds. water level; Erosion control driver

GROUP 4: Driver of transit mix truck, under 3 yds.; Dumpcrete truck, less than 6-1/2 yds. water level

GROUP 5: Water truck, 3 or more axles; Truck greaser and tire person (\$0.50 additional for tire person); Pipeline and utility working truck driver, including winch truck and plastic fusion, limited to pipeline and utility work; Slurry truck driver

GROUP 6: Transit mix truck, 3 yds. or more; Dumpcrete truck, 6-1/2 yds. water level and over; Vehicle or combination of vehicles - 4 or more axles; Oil spreader truck; Dump truck, 16 yds. to 25 yds. water level

GROUP 7: A Frame, Swedish crane or similar; Forklift driver; Ross carrier driver

GROUP 8: Dump truck, 25 yds. to 49 yds. water level; Truck repair person; Water pull - single engine; Welder

GROUP 9: Truck repair person/welder; Low bed driver, 9 axles or over

GROUP 10: Dump truck - 50 yds. or more water level; Water pull - single engine with attachment

GROUP 11: Water pull - twin engine; Water pull - twin engine with attachments; Winch truck driver - \$1.25 additional when operating winch or similar special attachments

GROUP 12: Boom Truck 17K and above

-----  
WELDERS - Receive rate prescribed for craft performing operation to which welding is incidental.

=====  
Note: Executive Order (EO) 13706, Establishing Paid Sick Leave for Federal Contractors applies to all contracts subject to the Davis-Bacon Act for which the contract is awarded (and any solicitation was issued) on or after January 1, 2017. If this contract is covered by the EO, the contractor must provide employees with 1 hour of paid sick leave for every 30 hours they work, up to 56 hours of paid sick leave each year.

Employees must be permitted to use paid sick leave for their own illness, injury or other health-related needs, including preventive care; to assist a family member (or person who is like family to the employee) who is ill, injured, or has other health-related needs, including preventive care; or for reasons resulting from, or to assist a family member (or person who is like family to the employee) who is a victim of, domestic violence, sexual assault, or stalking. Additional information on contractor requirements and worker protections under the EO (VII) Reports, Supplements, Attachments, Modifications and Exhibits

is available at  
https://www.dol.gov/agencies/whd/government-contracts.

Unlisted classifications needed for work not included within the scope of the classifications listed may be added after award only as provided in the labor standards contract clauses (29CFR 5.5 (a) (1) (ii)).

-----  
The body of each wage determination lists the classification and wage rates that have been found to be prevailing for the cited type(s) of construction in the area covered by the wage determination. The classifications are listed in alphabetical order of ""identifiers"" that indicate whether the particular rate is a union rate (current union negotiated rate for local), a survey rate (weighted average rate) or a union average rate (weighted union average rate).

Union Rate Identifiers

A four letter classification abbreviation identifier enclosed in dotted lines beginning with characters other than ""SU"" or ""UAVG"" denotes that the union classification and rate were prevailing for that classification in the survey. Example: PLUM0198-005 07/01/2014. PLUM is an abbreviation identifier of the union which prevailed in the survey for this classification, which in this example would be Plumbers. 0198 indicates the local union number or district council number where applicable, i.e., Plumbers Local 0198. The next number, 005 in the example, is an internal number used in processing the wage determination. 07/01/2014 is the effective date of the most current negotiated rate, which in this example is July 1, 2014.

Union prevailing wage rates are updated to reflect all rate changes in the collective bargaining agreement (CBA) governing this classification and rate.

Survey Rate Identifiers

Classifications listed under the ""SU"" identifier indicate that no one rate prevailed for this classification in the survey and the published rate is derived by computing a weighted average rate based on all the rates reported in the survey for that classification. As this weighted average rate includes all rates reported in the survey, it may include both union and non-union rates. Example: SULA2012-007 5/13/2014. SU indicates the rates are survey rates based on a weighted average calculation of rates and are not majority rates. LA indicates the State of Louisiana. 2012 is the year of survey on which these classifications and rates are based. The next number, 007 in the example, is an internal number used in producing the wage determination. 5/13/2014 indicates the survey completion date for the classifications and rates under that identifier.

Survey wage rates are not updated and remain in effect until a new survey is conducted.

Union Average Rate Identifiers

Classification(s) listed under the UAVG identifier indicate that no single majority rate prevailed for those classification(s). However, 100% of the data reported for the classification(s) is derived from the survey. (ii) Reports, Supplements, Attachments, Modifications and Exhibits

classifications was union data. EXAMPLE: UAVG-OH-0010 08/29/2014. UAVG indicates that the rate is a weighted union average rate. OH indicates the state. The next number, 0010 in the example, is an internal number used in producing the wage determination. 08/29/2014 indicates the survey completion date for the classifications and rates under that identifier.

A UAVG rate will be updated once a year, usually in January of each year, to reflect a weighted average of the current negotiated/CBA rate of the union locals from which the rate is based.

-----

WAGE DETERMINATION APPEALS PROCESS

1.) Has there been an initial decision in the matter? This can be:

- \* an existing published wage determination
- \* a survey underlying a wage determination
- \* a Wage and Hour Division letter setting forth a position on a wage determination matter
- \* a conformance (additional classification and rate) ruling

On survey related matters, initial contact, including requests for summaries of surveys, should be with the Wage and Hour National Office because National Office has responsibility for the Davis-Bacon survey program. If the response from this initial contact is not satisfactory, then the process described in 2.) and 3.) should be followed.

With regard to any other matter not yet ripe for the formal process described here, initial contact should be with the Branch of Construction Wage Determinations. Write to:

Branch of Construction Wage Determinations  
Wage and Hour Division  
U.S. Department of Labor  
200 Constitution Avenue, N.W.  
Washington, DC 20210

2.) If the answer to the question in 1.) is yes, then an interested party (those affected by the action) can request review and reconsideration from the Wage and Hour Administrator (See 29 CFR Part 1.8 and 29 CFR Part 7). Write to:

Wage and Hour Administrator  
U.S. Department of Labor  
200 Constitution Avenue, N.W.  
Washington, DC 20210

The request should be accompanied by a full statement of the interested party's position and by any information (wage payment data, project description, area practice material, etc.) that the requestor considers relevant to the issue.

3.) If the decision of the Administrator is not favorable, an interested party may appeal directly to the Administrative Review Board (formerly the Wage Appeals Board). Write to:

Administrative Review Board  
U.S. Department of Labor  
200 Constitution Avenue, N.W.

(vii) Reports, Supplements, Attachments,  
Modifications and Exhibits



Washington, DC 20210

4.) All decisions by the Administrative Review Board are final.

=====

END OF GENERAL DECISIO"

**OCEANO COMMUNITY SERVICES DISTRICT**  
**WATER STORAGE TANK REHABILITATION PROJECT**

**INSURANCE REQUIREMENTS**

**FOR**

**OCEANO, CA**  
**CONTRACT NO. 2023-01**

# INSURANCE REQUIREMENTS

## INDEMNIFICATION

To the fullest extent permitted by law, CONTRACTOR shall indemnify, defend and hold harmless the District and its officers, agents, employees, and volunteers from and against all claims, demands, damages, liabilities, loss, costs, and expense (including attorney's fees and costs of litigation) of every nature arising out of or in connection with Contractor's performance or attempted performance of work hereunder or its failure to comply with any of its obligations contained in the agreement, except such loss or damage which was caused by sole negligence or willful misconduct of the District.

## INSURANCE COVERAGE

Contractor shall procure and maintain for the duration of the contract insurance against claims for injuries to persons or damages to property which may arise from or in connection with the performance of the work hereunder by the Contractor, its agents, representatives, or employees.

## MINIMUM SCOPE AND LIMIT OF INSURANCE

Coverage shall be at least as broad as:

1. Commercial General Liability (CGL); Insurance Services Office (ISO) Form CG 0001 covering CGL on an "occurrence" basis for bodily injury and property damage, including products-completed, operations, personal injury and advertising injury, with limits no less than \$1,000,000 per occurrence. If a general aggregate limit applies either the general aggregate limit shall apply separately to this project/location or the general aggregate limit shall be twice the required occurrence limit.
2. Automobile Liability: ISO Form Number CA 0001 covering, Code 1 (any auto), or if Contractor has no owned autos, Code 8 (hired) and 9 (non-owned), with limit no less than \$1,000,000 per accident for bodily injury and property damages.
3. Worker Compensation insurance as required by the State of California, with Statutory Limits, and Employer's Liability insurance with limit of no less than \$1,000,000 per accident for bodily injury or disease. If Contractor will provide leased employees, or is an employee leasing or temporary staffing firm or a professional employer organization (PEO), coverage shall also include an Alternate Employer Endorsement (providing scope of coverage equivalent to ISO policy form WC 00 03 O1 A) naming the District as the Alternate Employer, and the endorsement form shall be modified to provide that District will receive not less than thirty (30) days advance written notice of cancellation of this coverage provision. If applicable to Contractor's operations, coverage also shall be arranged to satisfy the requirements of any federal workers or workmen's compensation law or any federal occupational disease law.  
*(Not required if Contractor provides written verification it has no employees)*

If the contractor maintains higher limits than the minimums shown above, the District requires and shall be entitled to coverage for the higher limits maintained by the contractor.

### **OTHER INSURANCE PROVISIONS**

The insurance policies are to contain, or be endorsed to contain, the following provisions:

#### *Additional Insured Status:*

The District, its officers, officials, employees, and volunteers are to be covered as insureds on the auto policy with respect to liability arising out of automobiles owned, leased, hired or borrowed by, or on behalf of the Contractor; and on the CGL policy with respect to liability arising out of work or operations performed by or on behalf of the Contractor including materials, parts, or equipment furnished in connection with such work or operations. General liability coverage can be provided in the form of an endorsement to the Contractor's insurance (at least as broad as ISO Form CG 20 10, 11 85 or both CG 20 10 and CG 23 37 forms if later revisions used).

#### *Primary Coverage*

For any claims related to this contract, the Contractor's insurance coverage shall be primary insurance as respects the District, its officers, officials, employees, and volunteers. Any insurance of self-insurance maintained by the District, its officers, officials, employees, or volunteers shall be excess of the Contractor's insurance and shall not contribute with it.

#### *Notice of Cancellation*

Each insurance policy required above shall state that coverage shall not be canceled, except after thirty (30) days prior written notice (10 days for non-payment) has been given to the District.

#### *Failure to Maintain Insurance*

Contractor's failure to maintain or to provide acceptable evidence that it maintains the required insurance shall constitute a material breach of the Contract upon which the District immediately may withhold payments due to Contractor, and/or suspend or terminate this Contract. The District, at its sole discretion, may obtain damages from Contractor resulting from said breach.

#### *Waiver of Subrogation*

Contractor hereby grants to District a waiver of any right to subrogation which any insurer of said Contractor may acquire against the District by virtue of the payment of any loss under such insurance. Contractor agrees to obtain any endorsement that may be necessary to affect this waiver of subrogation, but this provision applies regardless of whether or not the District has received a waiver of subrogation endorsement from the insurer.

#### *Deductibles and Self-Insured Retentions*

Any deductibles or self-insured retentions must be declared to and approved by the District. The District may require the Contractor to provide proof of ability to pay losses and related investigation, claim administration, and defense expenses within the retention.

#### *Acceptability of Insurers*

Insurance is to be placed with insurers with a current A.A. Best's rating of no less than A:VII, unless otherwise acceptable to the District.

### *Claims Made Policies*

If any of the required policies provide coverage on a claims-made basis:

1. The Retroactive Date must be shown and must be before the date of the contract or the beginning of contract work;
2. Insurance must be maintained and evidence of insurance must be provided for at least five (5) years after completion of the contract of work;
3. If coverage is canceled or non-renewed, and not replaced with another claims-made policy form with a Retroactive date prior to the contract effective date, the Contractor must purchase "extended reporting" coverage for a minimum of five (5) years.

### *Separation of Insured's*

All liability policies shall provide cross-liability coverage as would be afforded by the standard ISO (Insurance Services Office, Inc.) separate of insured's provision with no insured versus insured exclusions or limitation.

### *Verification of Coverage*

Contractor shall furnish the District with original certificates and mandatory endorsements or copies of the applicable policy language effecting coverage required by this clause. All certificates and endorsements are to be received and approved by the District before work commences. However, failure to obtain the required documents prior to the work beginning shall not waive the Contractor's obligation to provide them. The District reserves the right to required complete, certified copies of all required insurance policies, including endorsements required by these specifications, at any time.

Certificates and copies of any required endorsements shall be sent to:

Oceano Community Services District  
P.O. Box 599  
Oceano, CA 93475-0599

### *Subcontractors*

Contractor shall require and verify that all subcontractors maintain insurance meeting all the requirements stated herein.

### *Special Risks or Circumstances*

District reserves the right to modify these requirements, including limits, based on the nature of the risk, prior experience, insurer, coverage, or other special circumstances.

**OCEANO COMMUNITY SERVICES DISTRICT**

**WATER STORAGE TANK REHABILITATION PROJECT**

**OCEANO, CA  
CONTRACT NO. 2023-03**

**PERFORMANCE AND PAYMENT BONDS**

**PERFORMANCE BOND**

CONTRACTOR (*Name and Address*):

SURETY (*Name, and Address of Principal Place of Business*):

OWNER (*Name and Address*):

Oceano Community Services District  
1655 Front Street  
Oceano, CA 93445  
Attention: General Manager

**CONSTRUCTION CONTRACT**

Effective Date of Agreement:

Amount:

Description: Water Storage Tank Rehabilitation Project, Oceano, Ca, Contract No 2023-03

**BOND**

Bond Number:

Date (*Not earlier than Effective Date of Agreement of the Construction Contract*):

Amount:

Modifications to this Bond Form:       None       See Paragraph 16

Surety and Contractor, intending to be legally bound hereby, subject to the terms set forth below, do each cause this Performance Bond to be duly executed by an authorized officer, agent, or representative.

**CONTRACTOR AS PRINCIPAL**

**SURETY**

\_\_\_\_\_(Seal)  
Contractor's Name and Corporate Seal

\_\_\_\_\_(Seal)  
Surety's Name and Corporate Seal

By: \_\_\_\_\_  
Signature

By: \_\_\_\_\_  
Signature (Attach Power of Attorney)

\_\_\_\_\_  
Print Name

\_\_\_\_\_  
Print Name

\_\_\_\_\_  
Title

\_\_\_\_\_  
Title

Attest: \_\_\_\_\_  
Signature

Attest: \_\_\_\_\_  
Signature

\_\_\_\_\_  
Title

\_\_\_\_\_  
Title

*Notes: (1) Provide supplemental execution by any additional parties, such as joint venturers, (2) Any singular reference to Contractor, Surety, Owner, or other party shall be considered plural where applicable.*

1. The Contractor and Surety, jointly and severally, bind themselves, their heirs, executors, administrators, successors, and assigns to the Owner for the performance of the Construction Contract, which is incorporated herein by reference.
2. If the Contractor performs the Construction Contract, the Surety and the Contractor shall have no obligation under this Bond, except when applicable to participate in a conference as provided in Paragraph 3.
3. If there is no Owner Default under the Construction Contract, the Surety's obligation under this Bond shall arise after:
  - 3.1 The Owner first provides notice to the Contractor and the Surety that the Owner is considering declaring a Contractor Default. Such notice shall indicate whether the Owner is requesting a conference among the Owner, Contractor, and Surety to discuss the Contractor's performance. If the Owner does not request a conference, the Surety may, within five (5) business days after receipt of the Owner's notice, request such a conference. If the Surety timely requests a conference, the Owner shall attend. Unless the Owner agrees otherwise, any conference requested under this Paragraph 3.1 shall be held within ten (10) business days of the Surety's receipt of the Owner's notice. If the Owner, the Contractor, and the Surety agree, the Contractor shall be allowed a reasonable time to perform the Construction Contract, but such an agreement shall not waive the Owner's right, if any, subsequently to declare a Contractor Default;
  - 3.2 The Owner declares a Contractor Default, terminates the Construction Contract and notifies the Surety; and
  - 3.3 The Owner has agreed to pay the Balance of the Contract Price in accordance with the terms of the Construction Contract to the Surety or to a contractor selected to perform the Construction Contract.
4. Failure on the part of the Owner to comply with the notice requirement in Paragraph 3.1 shall not constitute a failure to comply with a condition precedent to the Surety's obligations, or release the Surety from its obligations, except to the extent the Surety demonstrates actual prejudice.
5. When the Owner has satisfied the conditions of Paragraph 3, the Surety shall promptly and at the Surety's expense take one of the following actions:
  - 5.1 Arrange for the Contractor, with the consent of the Owner, to perform and complete the Construction Contract;
  - 5.2 Undertake to perform and complete the Construction Contract itself, through its agents or independent contractors;
  - 5.3 Obtain bids or negotiated proposals from qualified contractors acceptable to the Owner for a contract for performance and completion of the Construction Contract, arrange for a contract to be prepared for execution by the Owner and a contractor selected with the Owners concurrence, to be secured with performance and payment bonds executed by a qualified surety equivalent to the bonds issued on the Construction Contract, and pay to the Owner the amount of damages as described in Paragraph 7 in excess of the Balance of the Contract Price incurred by the Owner as a result of the Contractor Default; or
  - 5.4 Waive its right to perform and complete, arrange for completion, or obtain a new contractor, and with reasonable promptness under the circumstances:
    - 5.4.1 After investigation, determine the amount for which it may be liable to the Owner and, as soon as practicable after the amount is determined, make payment to the Owner; or
    - 5.4.2 Deny liability in whole or in part and notify the Owner, citing the reasons for denial.
6. If the Surety does not proceed as provided in Paragraph 5 with reasonable promptness, the Surety shall be deemed to be in default on this Bond seven days after receipt of an additional written notice from the



Owner to the Surety demanding that the Surety perform its obligations under this Bond, and the Owner shall be entitled to enforce any remedy available to the Owner. If the Surety proceeds as provided in Paragraph 5.4, and the Owner refuses the payment, or the Surety has denied liability, in whole or in part, without further notice the Owner shall be entitled to enforce any remedy available to the Owner.

7. If the Surety elects to act under Paragraph 5.1, 5.2, or 5.3, then the responsibilities of the Surety to the Owner shall not be greater than those of the Contractor under the Construction Contract, and the responsibilities of the Owner to the Surety shall not be greater than those of the Owner under the Construction Contract. Subject to the commitment by the Owner to pay the Balance of the Contract Price, the Surety is obligated, without duplication for:
    - 7.1 the responsibilities of the Contractor for correction of defective work and completion of the Construction Contract;
    - 7.2 additional legal, design professional, and delay costs resulting from the Contractor's Default, and resulting from the actions or failure to act of the Surety under Paragraph 5; and
    - 7.3 liquidated damages, or if no liquidated damages are specified in the Construction Contract, actual damages caused by delayed performance or non-performance of the Contractor.
  8. If the Surety elects to act under Paragraph 5.1, 5.3, or 5.4, the Surety's liability is limited to the amount of this Bond.
  9. The Surety shall not be liable to the Owner or others for obligations of the Contractor that are unrelated to the Construction Contract, and the Balance of the Contract Price shall not be reduced or set off on account of any such unrelated obligations. No right of action shall accrue on this Bond to any person or entity other than the Owner or its heirs, executors, administrators, successors, and assigns.
  10. The Surety hereby waives notice of any change, including changes of time, to the Construction Contract or to related subcontracts, purchase orders, and other obligations.
  11. Any proceeding, legal or equitable, under this Bond may be instituted in any court of competent jurisdiction in the location in which the work or part of the work is located and shall be instituted within two years after a declaration of Contractor Default or within two years after the Contractor ceased working or within two years after the Surety refuses or fails to perform its obligations under this Bond, whichever occurs first. If the provisions of this paragraph are void or prohibited by law, the minimum periods of limitations available to sureties as a defense in the jurisdiction of the suit shall be applicable.
  12. Notice to the Surety, the Owner, or the Contractor shall be mailed or delivered to the address shown on the page on which their signature appears.
  13. When this Bond has been furnished to comply with a statutory or other legal requirement in the location where the construction was to be performed, any provision in this Bond conflicting with said statutory or legal requirement shall be deemed deleted here from and provisions conforming to such statutory or other legal requirement shall be deemed incorporated herein. When so furnished, the intent is that this Bond shall be construed as a statutory bond and not as a common law bond.
  14. Definitions
    - 14.1 Balance of the Contract Price: The total amount payable by the Owner to the Contractor under the Construction Contract after all proper adjustments have been made including allowance for the Contractor for any amounts received or to be received by the Owner in settlement of insurance or other claims for damages to which the Contractor is entitled, reduced by all valid and proper payments made to or on behalf of the Contractor under the Construction Contract.
    - 14.2 Construction Contract: The agreement between the Owner and Contractor identified on the cover page, including all Contract Documents and changes made to the agreement and the Contract Documents.
    - 14.3 Contractor Default: Failure of the Contractor, which has not been remedied or waived, to perform or
- (x) Performance and Payment Bond Forms

otherwise to comply with a material term of the Construction Contract.

14.4 Owner Default: Failure of the Owner, which has not been remedied or waived, to pay the Contractor as required under the Construction Contract or to perform and complete or comply with the other material terms of the Construction Contract.

14.5 Contract Documents: All the documents that comprise the agreement between the Owner and Contractor.

15. If this Bond is issued for an agreement between a contractor and subcontractor, the term Contractor in this Bond shall be deemed to be Subcontractor and the term Owner shall be deemed to be Contractor.

16. Modifications to this Bond are as follows:

17. The effective date of this Bond shall be the same date as the Effective Date of the Construction Contract.

**END OF SECTION**

**PAYMENT BOND**

CONTRACTOR (*Name and Address*):

SURETY (*Name, and Address of Principal Place of Business*):

OWNER (*Name and Address*):

Oceano Community Services District  
1655 Front Street  
Oceano, CA 93445  
Attention: General Manager

**CONSTRUCTION CONTRACT**

Effective Date of Agreement:

Amount:

Description: Water Storage Tank Rehabilitation Project, Oceano, Ca, Contract No 2022-03

**BOND**

Bond Number:

Date (*Not earlier than Effective Date of Agreement of the Construction Contract*):

Amount:

Modifications to this Bond Form:       None       See Paragraph 18

Surety and Contractor, intending to be legally bound hereby, subject to the terms set forth below, do each cause this Performance Bond to be duly executed by an authorized officer, agent, or representative.

**CONTRACTOR AS PRINCIPAL**

**SURETY**

\_\_\_\_\_  
(Seal)  
Contractor's Name and Corporate Seal

\_\_\_\_\_  
(Seal)  
Surety's Name and Corporate Seal

By: \_\_\_\_\_  
Signature

By: \_\_\_\_\_  
Signature (Attach Power of Attorney)

\_\_\_\_\_  
Print Name

\_\_\_\_\_  
Print Name

\_\_\_\_\_  
Title

\_\_\_\_\_  
Title

Attest: \_\_\_\_\_  
Signature

Attest: \_\_\_\_\_  
Signature

\_\_\_\_\_  
Title

\_\_\_\_\_  
Title

Notes: (1) Provide supplemental execution by any additional parties, such as joint venturers, (2) Any singular reference to Contractor, Surety, Owner, or other party shall be considered plural where applicable.

1. The Contractor and Surety, jointly and severally, bind themselves, their heirs, executors, administrators, successors, and assigns to the Owner to pay for labor, materials, and equipment furnished for use in the performance of the Construction Contract, which is incorporated herein by reference, subject to the following terms.
2. If the Contractor promptly makes payment of all sums due to Claimants, and defends, indemnifies, and holds harmless the Owner from claims, demands, liens, or suits by any person or entity seeking payment for labor, materials, or equipment furnished for use in the performance of the Construction Contract, then the Surety and the Contractor shall have no obligation under this Bond.
3. If there is no Owner Default under the Construction Contract, the Surety's obligation to the Owner under this Bond shall arise after the Owner has promptly notified the Contractor and the Surety (at the address described in Paragraph 13) of claims, demands, liens, or suits against the Owner or the Owner's property by any person or entity seeking payment for labor, materials, or equipment furnished for use in the performance of the Construction Contract, and tendered defense of such claims, demands, liens, or suits to the Contractor and the Surety.
4. When the Owner has satisfied the conditions in Paragraph 3, the Surety shall promptly and at the Surety's expense defend, indemnify, and hold harmless the Owner against a duly tendered claim, demand, lien, or suit.
5. The Surety's obligations to a Claimant under this Bond shall arise after the following:
  - 5.1 Claimants who do not have a direct contract with the Contractor,
    - 5.1.1 have furnished a written notice of non-payment to the Contractor, stating with substantial accuracy the amount claimed and the name of the party to whom the materials were, or equipment was, furnished or supplied or for whom the labor was done or performed, within ninety (90) days after having last performed labor or last furnished materials or equipment included in the Claim; and
    - 5.1.2 have sent a Claim to the Surety (at the address described in Paragraph 13).
  - 5.2 Claimants who are employed by or have a direct contract with the Contractor have sent a Claim to the Surety (at the address described in Paragraph 13).
6. If a notice of non-payment required by Paragraph 5.1.1 is given by the Owner to the Contractor, that is sufficient to satisfy a Claimant's obligation to furnish a written notice of non-payment under Paragraph 5.1.1.
7. When a Claimant has satisfied the conditions of Paragraph 5.1 or 5.2, whichever is applicable, the Surety shall promptly and at the Surety's expense take the following actions:
  - 7.1 Send an answer to the Claimant, with a copy to the Owner, within sixty (60) days after receipt of the Claim, stating the amounts that are undisputed and the basis for challenging any amounts that are disputed; and
  - 7.2 Pay or arrange for payment of any undisputed amounts.
  - 7.3 The Surety's failure to discharge its obligations under Paragraph 7.1 or 7.2 shall not be deemed to constitute a waiver of defenses the Surety or Contractor may have or acquire as to a Claim, except as to undisputed amounts for which the Surety and Claimant have reached agreement. If, however, the Surety fails to discharge its obligations under Paragraph 7.1 or 7.2, the Surety shall indemnify the Claimant for the reasonable attorney's fees the Claimant incurs thereafter to recover any sums found to be due and owing to the Claimant.
8. The Surety's total obligation shall not exceed the amount of this Bond, plus the amount of reasonable attorney's fees provided under Paragraph 7.3, and the amount of this Bond shall be credited for any payments made in good faith by the Surety.
9. Amounts owed by the Owner to the Contractor under the Construction Contract shall be used for the

performance of the Construction Contract and to satisfy claims, if any, under any construction performance bond. By the Contractor furnishing and the Owner accepting this Bond, they agree that all funds earned by the Contractor in the performance of the Construction Contract are dedicated to satisfy obligations of the Contractor and Surety under this Bond, subject to the Owner's priority to use the funds for the completion of the work.

10. The Surety shall not be liable to the Owner, Claimants, or others for obligations of the Contractor that are unrelated to the Construction Contract. The Owner shall not be liable for the payment of any costs or expenses of any Claimant under this Bond and shall have under this Bond no obligation to make payments to or give notice on behalf of Claimants, or otherwise have any obligations to Claimants under this Bond.
11. The Surety hereby waives notice of any change, including changes of time, to the Construction Contract or to related subcontracts, purchase orders, and other obligations.
12. No suit or action shall be commenced by a Claimant under this Bond other than in a court of competent jurisdiction in the state in which the project that is the subject of the Construction Contract is located or after the expiration of one year from the date (1) on which the Claimant sent a Claim to the Surety pursuant to Paragraph 5.1.2 or 5.2, or (2) on which the last labor or service was performed by anyone or the last materials or equipment were furnished by anyone under the Construction Contract, whichever of (1) or (2) first occurs. If the provisions of this paragraph are void or prohibited by law, the minimum period of limitation available to sureties as a defense in the jurisdiction of the suit shall be applicable.
13. Notice and Claims to the Surety, the Owner, or the Contractor shall be mailed or delivered to the address shown on the page on which their signature appears. Actual receipt of notice or Claims, however accomplished, shall be sufficient compliance as of the date received.
14. When this Bond has been furnished to comply with a statutory or other legal requirement in the location where the construction was to be performed, any provision in this Bond conflicting with said statutory or legal requirement shall be deemed deleted herefrom and provisions conforming to such statutory or other legal requirement shall be deemed incorporated herein. When so furnished, the intent is that this Bond shall be construed as a statutory bond and not as a common law bond.
15. Upon requests by any person or entity appearing to be a potential beneficiary of this Bond, the Contractor and Owner shall promptly furnish a copy of this Bond or shall permit a copy to be made.
16. Definitions
  - 16.1 Claim: A written statement by the Claimant including at a minimum:
    1. The name of the Claimant;
    2. The name of the person for whom the labor was done, or materials or equipment furnished;
    3. A copy of the agreement or purchase order pursuant to which labor, materials, or equipment was furnished for use in the performance of the Construction Contract;
    4. A brief description of the labor, materials, or equipment furnished;
    5. The date on which the Claimant last performed labor or last furnished materials or equipment for use in the performance of the Construction Contract;
    6. The total amount earned by the Claimant for labor, materials, or equipment furnished as of the date of the Claim;
    7. The total amount of previous payments received by the Claimant; and
    8. The total amount due and unpaid to the Claimant for labor, materials, or equipment furnished as of the date of the Claim.

- 16.2 Claimant: An individual or entity having a direct contract with the Contractor or with a subcontractor of the Contractor to furnish labor, materials, or equipment for use in the performance of the Construction Contract. The term Claimant also includes any individual or entity that has rightfully asserted a claim under an applicable mechanic's lien or similar statute against the real property upon which the Project is located. The intent of this Bond shall be to include without limitation in the terms of "labor, materials, or equipment" that part of the water, gas, power, light, heat, oil, gasoline, telephone service, or rental equipment used in the Construction Contract, architectural and engineering services required for performance of the work of the Contractor and the Contractor's subcontractors, and all other items for which a mechanic's lien may be asserted in the jurisdiction where the labor, materials, or equipment were furnished.
- 16.3 Construction Contract: The agreement between the Owner and Contractor identified on the cover page, including all Contract Documents and all changes made to the agreement and the Contract Documents.
- 16.4 Owner Default: Failure of the Owner, which has not been remedied or waived, to pay the Contractor as required under the Construction Contract or to perform and complete or comply with the other material terms of the Construction Contract.
- 16.5 Contract Documents: All the documents that comprise the agreement between the Owner and Contractor.
17. If this Bond is issued for an agreement between a contractor and subcontractor, the term Contractor in this Bond shall be deemed to be Subcontractor and the term Owner shall be deemed to be Contractor.
18. Modifications to this Bond are as follows:
19. The effective date of this Bond shall be the same date as the Effective Date of the Construction Contract.

**ENDOFSECTION**

**RULES GOVERNING BID PROTESTS AND OTHER CHALLENGES TO  
AWARDS OF CONSTRUCTION CONTRACTS**

THIS PAGE LEFT BLANK INTENTIONALLY



# OCEANO COMMUNITY SERVICES DISTRICT

## Rules Governing Bid Protests And Other Challenges to Awards of Construction Contracts

---

The requirements set forth in these “Rules Governing Bid Protests And Other Challenges to Awards of Construction Contracts” (“Rules”) are mandatory and are a Bidder’s sole and exclusive remedy in the event a Bidder desires to challenge, protest or contest the award of any Construction Contract. A Bidder’s failure to comply with these requirements shall constitute a waiver of any right to challenge, protest or contest the award of a Construction Contract in any subsequent proceeding, including but not limited to, the filing of a court action.

A Bidder may not rely upon another Bidder’s compliance with the requirements of these Rules. Any Bidder that does not independently comply with the requirements set forth herein shall be deemed to have waived any right to challenge, protest or contest the award of a Construction Contract.

Nothing in these Rules affects the right of the District to reject all bids at any time prior to the award of a Construction Contract, or for the District to self-perform as provided by Public Contract Code 22038, all of which shall not constitute grounds for a bid protest.

### 1.1 Definitions

- 1.1.1 Bidder - The contractor submitting a bid in response to a District solicitation for bids on a Construction Contract.
- 1.1.2 Protestor - A Bidder who files a Protest in accordance with the provisions of these Rules.
- 1.1.3 Board – Board of Directors of the Oceano Community Services District (hereinafter, also “District”)
- 1.1.4 Construction Contract - Any Construction Contract which is formally or informally advertised for bids in which the District, or will be, a party.
- 1.1.5 Protest – Any challenge, objection, or protest to the award of a Construction Contract to any Bidder.
- 1.1.6 Response – Any response to a Protest that is filed by an Interested

Party in accordance with the provisions of these Rules.

General Manager - The person designated by the Board to assume the powers, duties, and responsibilities conferred under these Rules.

- 1.1.7 Initial Determination – A written notice by the General Manager that notifies a Bidder of the reasons why the General Manager believes that a bid is nonresponsive, or that a Bidder is not a responsible Bidder.
- 1.1.8 Interested Parties - For the purpose of these Rules, Interested Parties are defined as:
  - 1.1.8.1 The District.
  - 1.1.8.2 Any Bidder that filed a Protest or whose bid is the subject of an Initial Determination.
  - 1.1.8.3 Any Bidder whose eligibility for having the Construction Contract awarded to it as a responsible Bidder with the lowest responsive bid would be affected by the outcome of a Protest or Initial Determination.

## 1.2 General Manager's Independent Authority to Determine Bid Responsiveness and Bidder Responsibility.

- 1.2.1 Regardless of whether a Protest is submitted under these Rules, the General Manager is authorized to determine whether any bid is a responsive bid and whether any Bidder is a responsible Bidder. In the event the General Manager issues an Initial Determination, the General Manager shall provide the Interested Parties with written notice of the Initial Determination at least five (5) business days before the General Manager renders a final decision addressing the grounds stated in the Initial Determination. A final decision of the General Manager under this section 1.2 shall be the final decision of the District with no provision for reconsideration or appeal to the Board.
- 1.2.2 The General Manager need not issue an Initial Determination in order to make a final decision on whether a bid is a responsive bid or a Bidder is a responsible Bidder. A final decision can also be issued by the General Manager through the processing of a Protest pursuant to the procedures set forth in these Rules.
- 1.2.3 The General Manager reserves the right to amend or withdraw an Initial Determination at any time before the General Manager renders a final decision addressing the grounds stated in the Initial Determination. When an Initial Determination is withdrawn, it shall have the same effect as if the Initial Determination had never been made.

## 1.3 Basis for Protest

- 1.3.1 Grounds for Protest – The grounds for a Protest may include any grounds a Protestor may have for contesting or challenging the award of a Construction Contract to any Bidder, including but not limited to the following grounds:

- 1.3.1.1 A Protestor objects to a Construction Contract being awarded to another Bidder on the grounds that the other Bidder's bid is nonresponsive.
- 1.3.1.2 A Protestor objects to a Construction Contract being awarded to another Bidder on the grounds that the other Bidder is not a responsible Bidder.
- 1.3.1.3 A Protestor objects to a Construction Contract being awarded to the Protestor on the grounds that the Protestor made a mistake in its bid that entitles the Protestor to be relieved of its bid under Public Contract Code Sections 5100 et seq
- 1.3.1.4 A Protestor objects to a General Manager's Initial Determination issued under section 1.2.1 above.
- 1.3.2 Required Form of Protest - All Protests shall be made in writing, containing the information listed below, and shall be filed with the General Manager. Protests shall contain the following information:
  - 1.3.2.1 The name, address, telephone, facsimile numbers, and email address of the Protestor.
  - 1.3.2.2 The signature of the Protestor or its representative.
  - 1.3.2.3 The bid, solicitation and/or contract number.
  - 1.3.2.4 The Protest must contain a complete statement of all grounds for the Protest, and must refer to the specific portion of the bid documents that are the basis of the Protest. The Protest must set forth all supporting facts and documentation. If Protester believes there are some facts relevant to its Protest that Protester cannot adequately present in writing, Protester must describe such facts in its Protest under the heading "Facts Requiring Oral Presentation", and state therein the reasons why the Bid Protester believes it cannot adequately present those facts through documentation.
  - 1.3.2.5 All information establishing that the Protestor is a Bidder for the purpose of filing a Protest.
  - 1.3.2.6 The form of relief requested.

#### 1.4 Protest Requirements and Procedure

- 1.4.1 Standing to Protest - Protests shall be filed only by a Bidder.
- 1.4.2 Time for Filing a Protest
  - 1.4.2.1 Except as provided in sections 1.4.2.2 and 1.4.2.3 below, all Protests must be submitted in writing to the General Manager before 5 p.m. PST of the sixth (6) business day following the date upon which the bids on the Construction Contract were opened.
  - 1.4.2.2 When a Protestor objects to a Construction Contract being awarded to the Protestor on the grounds that the Protestor made a mistake in its bid that entitles the Protestor to be relieved of its bid under Public Contract Code Sections 5100 et seq, the Protest must be submitted in writing to the General Manager before 5 p.m. PST of the fifth (5) business day following the date upon

which the bids on the Construction Contract were opened pursuant to Public Contract Code Section 5103.

- 1.4.2.3 When the Protestor objects to an Initial Determination made by the General Manager under section 1.2.1 above, the Protest must be submitted in writing to the General Manager before 5 p.m. PST of the fifth (5) business day following the date upon which the Initial Determination was first delivered to Protestor (either electronically or otherwise).
- 1.4.3 Written Responses of Interested Parties - If any Interested Party desires to respond to the Protest, the Response must be submitted in writing to the General Manager within five (5) business days of the date the Protest was first delivered to the Interested Party (either electronically or otherwise). If an Interested Party believes there are some facts relevant to its Response that the Interested Party cannot adequately present in writing, the Interested Party must describe such facts in its Response under the heading "Facts Requiring Oral Presentation", and state therein the reasons why the Interested Party believes it cannot adequately present those facts through documentation.
- 1.4.4 Proof of Transmittal - All Protests, Responses, and Replies shall include documentation evidencing that all Interested Parties were concurrently sent a complete copy of the respective Protest, Response or Reply in a manner that would provide all Interested Parties with a complete copy of the respective Protest, Response or Reply no later than one (1) business day after it was sent to the General Manager. The means of transmission chosen must also provide the sending party a means of verifying the date and time the copy was received by each Interested Party. Transmission by email may be an acceptable means of transmittal.
- 1.4.5 No Ex Parte or Unilateral Communications on the Merits of a Protest - No Bidder shall have any written communications regarding the merits of a Protest with the General Manager that are not concurrently sent to all of the other Interested Parties. No Bidder shall have any oral communications regarding the merits of a Protest with the General Manager other than during an oral presentation properly noticed by the General Manager under these Rules.
- 1.4.6 Suspension of Process for Proposed Rejection of all Bids - At any time during the processing of a Protest, the General Manager may elect to indefinitely suspend any further processing of the Protest by providing written notice to all Interested Parties that the General Manager intends to recommend to the Board that all bids be rejected. All time deadlines provided in these Rules shall be tolled during any such suspension period. If the Board decides to not reject all bids, or if the General Manager otherwise decides to lift the suspension, the requirements of these Rules shall be reactivated upon the General Manager providing all Interested Parties with written notice thereof.

## 1.5 Summary Dismissal of Protest

The General Manager may summarily dismiss a protest, or specific protest allegations, at any time that the General Manager determines that the Protest is untimely, frivolous, or without merit; is not submitted in the required form of Protest, as set forth above in section 1.3.2., "Required Form of Protest;" or is submitted by a non-Bidder. In such cases, a notice of summary dismissal will be furnished to the Interested Parties. Such a summary dismissal shall be the final decision of the District with no provision for reconsideration or appeal to the Board.

## 1.6 Decision by the General Manager Based on Written Submissions Only

In reaching a decision on the merits of a Protest, the General Manager may consider relevant documentation submitted by the Protestor and any other Interested Party. If the General Manager wishes to have additional information submitted that was not included in the Protest or in any documentation from other Interested Parties, the General Manager may make a request specifying the information sought and time for submittal. Submissions of additional information that have not been specifically requested by the General Manager may not be considered at the General Manager's sole discretion. If the General Manager does not provide an opportunity for an oral presentation under section 1.7 below, the General Manager will issue a written decision without any oral presentation. . The General Manager's decision shall be the final decision of the District with no provision for reconsideration or appeal to the Board.

## 1.7 Decision by the General Manager Following Oral Presentation

1.7.1 The General Manager may, at his or her discretion, elect to provide an opportunity for the Protestor and other Interested Parties to make an oral presentation to the General Manager regarding the Protest. In such event, oral presentations shall be conducted in accordance with the following procedure:

1.7.1.1 Notice of Oral Presentation - The General Manager will set a date, time, and place for an oral presentation. Written notice will be sent to Interested Parties not less than five (5) business days in advance of the oral presentation unless it is agreeable to all parties that an earlier date be established. Continuances may be granted by the General Manager for good cause.

1.7.1.2 Guidelines for Oral Presentation - Oral presentations are informal in nature and shall be made by the Protestor or its authorized representative. Technical rules of evidence shall not apply. The General Manager will determine how the oral presentations will be conducted and may set time limits for the presentation. The General Manager may question Interested Parties or provide an opportunity for Interested Parties to make an oral presentation. The General Manager may request additional documentation or information prior to, during or after the oral presentation. Unless

requested by the General Manager, additional documentation or information may not be accepted.

1.7.1.3 Record of Oral Presentation - Any Interested Party may request, and in the General Manager's sole discretion, the General Manager may allow recording of the presentation. If the General Manager allows the presentation to be recorded, the Interested Party requesting that the presentation be recorded must pay the cost of recording, including the costs to make and distribute copies of the recording to the General Manager and other Interested Parties. There shall be no cost to the District.

1.7.1.4 Decisions - The General Manager will issue a written decision within 30 calendar days of the oral presentation; however, the time for issuing the written decision may be extended by the General Manager. A copy of the decision will be furnished to the Interested Parties. The decision shall be the final decision of the District with no provision for reconsideration or appeal to the Board.

## 1.8 Effect on Contracts

The failure of a District employee or department to comply with the provisions stated in these Rules shall in no way affect the validity of any Construction Contract entered into by the District.

## 1.9 General Manager Decisions on Protests Seeking Relief from a Bidder's Mistake under Public Contract Code Section 5103.

When a Protestor objects to a Construction Contract being awarded to the Bid Protester on the grounds that the Protestor made a mistake in its bid that entitles the Protestor to be relieved of its bid under Public Contract Code Sections 5100 et seq, a final decision of the General Manager that relieves the Protestor of its bid on the grounds of mistake must be approved by the Board before it can become a final decision of the District. Any other final decision of the General Manager regarding a Protestor's request to be relieved of its bid on the grounds of mistake under Public Contract Code Sections 5100 et seq, shall be the final decision of the District with no provision for reconsideration or appeal to the Board.